



VACUUM PUMPING EQUIPMENT 290 235 03G2.5G

Installation and Operations Manual

Index

Page 1 Equipment Description	Page 6 Pumping Out A Boat
Page 2 Components & Dimensions	Page 7 Parts List
Page 3 Operation Guidelines	Page 8 Maintenance
Page 4 Vacuum/Pressure Regulators	Page 9 Trouble Shooting
Page 5 Suction Hose & Start-Up	

The Pump Out System

290 235 03G2.5G - Specifies that this Edson vacuum pumping equipment was built with a 235 gallon, galvanized steel transfer tank and Model 03, rotary vane, vacuum pump driven by a 2.5 hp, gasoline engine. This vacuum unit will develop 22" hg of vacuum (25 ft of suction lift) and 10 psi (23 ft of discharge head) and has a manually operated 4 way slide valve to cycle tank from suction to discharge when the tank is full.

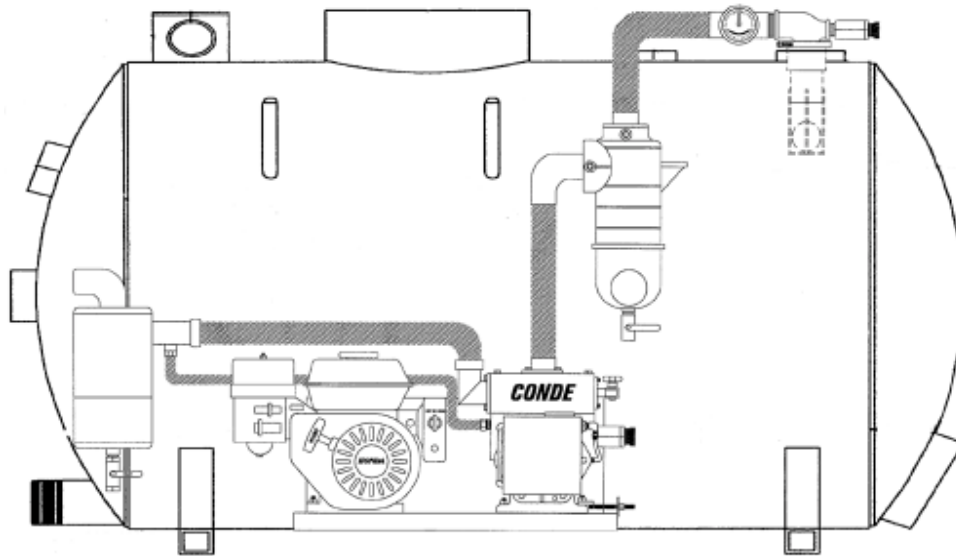

ENTER YOUR SYSTEM DATA HERE

SYSTEM SERIAL #
From Edson Serial # Sticker On Pump Frame

VACUUM PUMP

Engine



Vacuum Unit: fig.1

- | | |
|------------------------------------|----------------------------------------------|
| 1 # 03 Conde Vacuum Pump | 11 Primary Shut Off |
| 2 2.5 HP Gasoline Engine | 12 Secondary Shut Off & Moisture Trap |
| 3 235 Gallon Galvanized Tank | 13 Oil Reservoir |
| 4 4 Way Slide Valve | 14 Oil Fill Cap |
| 5 Level Sight Eyes | 15 Air Line to Tank |
| 6 Suction Port | 16 Exhaust Line to Oil Catch fro Slide Valve |
| 7 Discharge Port | 17 Pressure Vent Line to Oil Catch |
| 8 Vacuum/Pressure Gauge Oil Filled | 18 Oil Catch Muffler |
| 9 Pressure Regulator | 19 Oil Catch Drain |
| 10 Vacuum Regulator | 20 Manway |

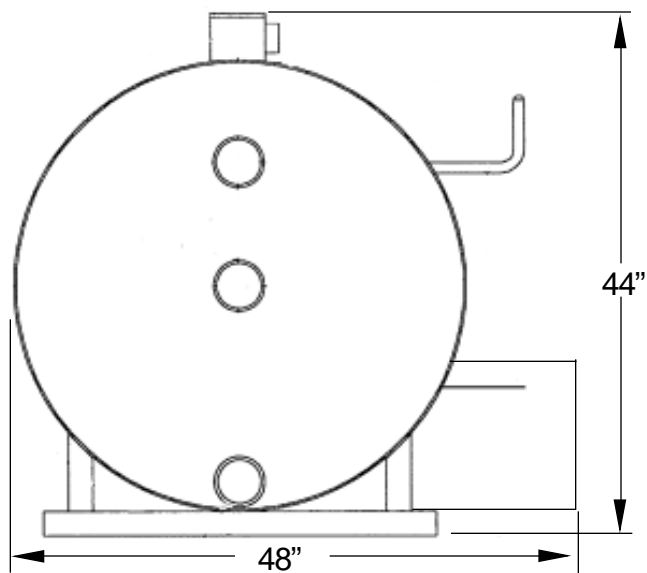
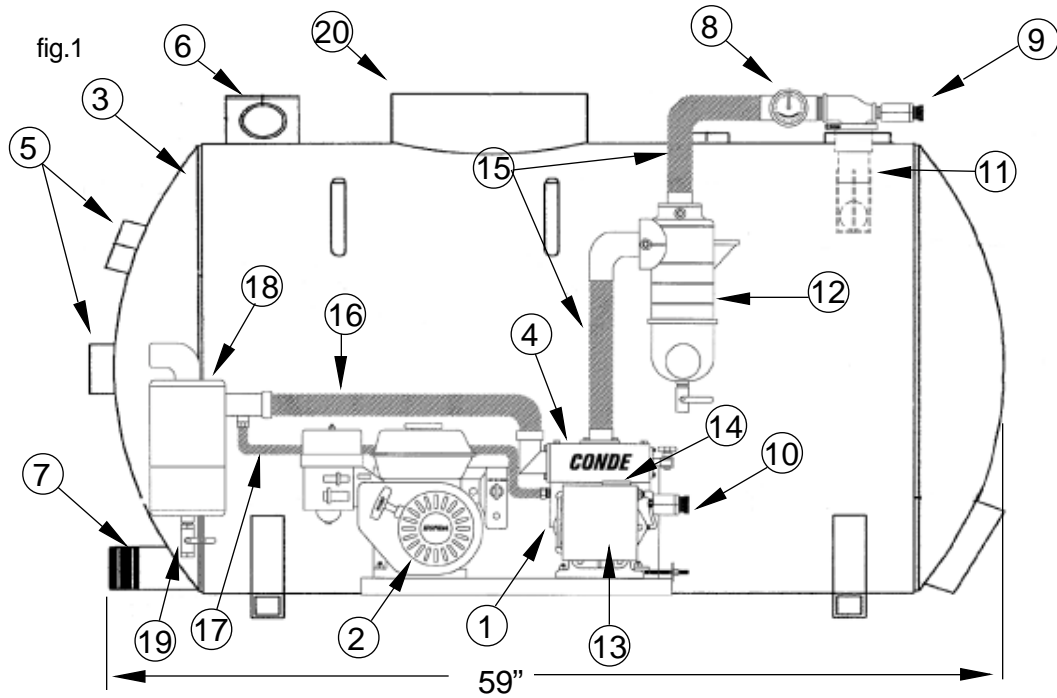

Operation Guidelines

IMPORTANT

Fill Vacuum Pump Oil Reservoir With 10W30 High Detergent Oil Before Starting System.

Failure to Do So Will Cause Damage to The Model 03 Vacuum Pump. For fill location see fig 1, item 14 page 2 of this manual.

IMPORTANT

Gas Engine Check Oil Level and Fill As Required Before Starting.

Failure to Do So Will Cause Damage to The Engine.

See Engine Operation Manual For Details.

1. Inspect the Complete Vacuum Unit

- Check All Bolts - Make sure that all bolts on the vacuum unit are secure.

2. Vacuum Pump -

- Fill Oil Reservoir - Using 10W30 or 10W40 high detergent motor oil.

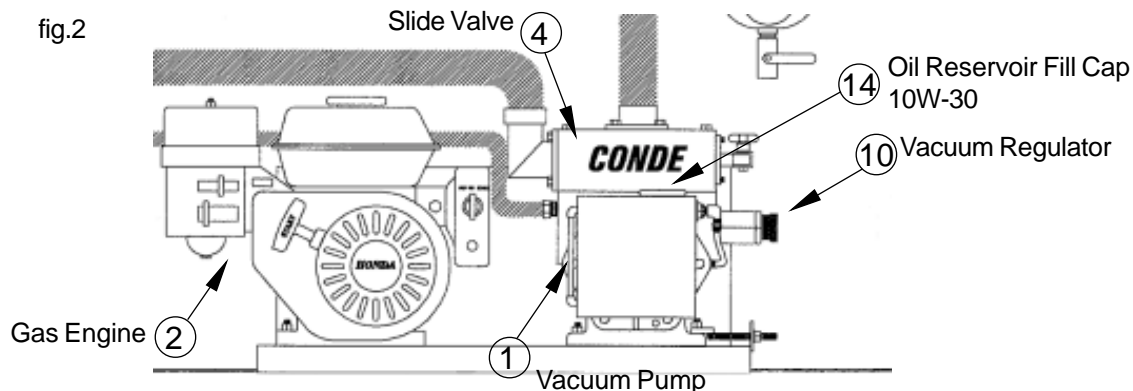

3. Gas Engine - Check Oil and Fill As Required.

- Check oil and fill as required.
- Read the engine manual before starting.

Warning

Slide Valve Handle Must Be Pulled Out In Vacuum Position On Start Up.

Failure to Do So Could Result In Serious Injury. If the Pump out Unit is turned on in the pressure mode, loose or insecure fittings can blow off and serious injury can result

4. Slide Valve - Start Unit With Slide Valve Handle Out In Vacuum Position.

- The slide valve controls the pressure and vacuum to the tank.
- Slide valve handle pulled out vacuum is created in the tank.
- Slide valve handle pushed in pressure is created in the tank.

WARNING

**Depressurize The System Before Removing Any Parts.
Never Adjust The Pressure Relief Regulator When The System Is On & There Is A
Pressure Reading On The Gauge. The Adjusting Nut Could Blow Off And Cause
Serious Injury**

- Check regulator settings on start up.
- Regulators have been factory set at 20" hg vacuum and 5 psi pressure.
- Close the ball valves at the top and bottom of the tank. Run the VacuMaster in vacuum for 2 to 3 minutes and record the gauge reading. Then run the VacuMaster in the pressure mode for 2 to 3 minutes and record the gauge reading.

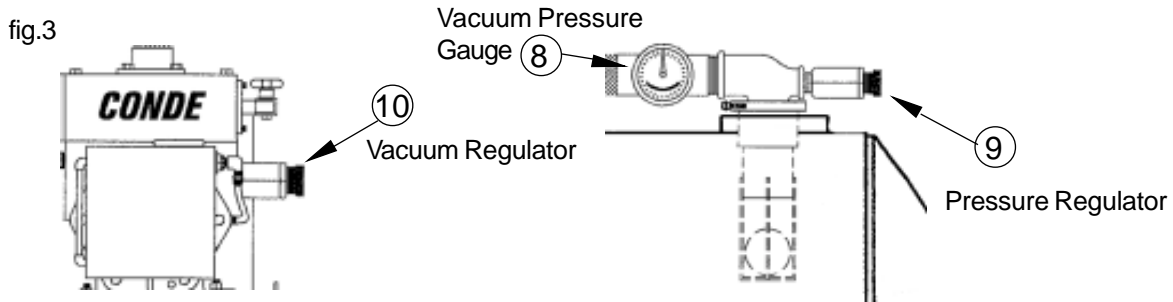

- To reset or adjust regulators use the following instructions:

Tools:
Adjustable Crescent Wrench
Channel Locks

Adjust Pressure Regulator 1

- Step 1 Close inlet and discharge ball valve.
- Step 2 Run VacuMaster in the pressure mode. Record pressure reading, turn system off. **Allow Tank To Depressurize. Do Not Adjust Pressure Regulator With System On. Regulator Screw Could Blow Loose and Cause Bodily Injury.**

Adjusting

- Step 3 Loosen locking nut counter clockwise.
 - Step 4 If pressure setting is too low, turn knurled hub clockwise to increase pressure at which valve opens. If pressure is too high, turn hub counter clockwise.
 - Step 5 Tighten locking nut. Turn on system.
- Repeat steps 2-5 until pressure is set.

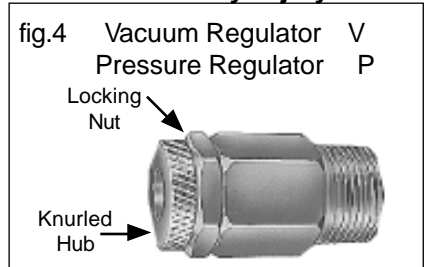

Adjust Vacuum Regulator 2

- Step 1 Close inlet and discharge ball valve.
- Step 2 Run VacuMaster in the vacuum mode. Record vacuum reading, turn system off. **Allow Tank To Depressurize. Do Not Adjust Pressure Regulator With System On. Regulator Adjusting Screw Could Blow Loose and Cause Bodily Injury.**

ing

- Step 3 Loosen locking nut counter clockwise.
 - Step 4 If vacuum setting is too low, turn knurled clockwise to increase pressure at which valve opens. If vacuum is too high, turn hub counter clockwise.
 - Step 5 Tighten locking nut. Turn on system.
- Repeat steps 2-5 until vacuum is set.

6. Install The Suction Hose Assembly.

- A good vacuum depends on an air tight suction hose.
- **Use Pipe Sealant On All Threads When Assembling Hose Components.**
- Connect suction hose to vacuum inlet at top of tank.
- If vacuum unit is equipped with marine boat pump out hose assembly see figure 5 below.

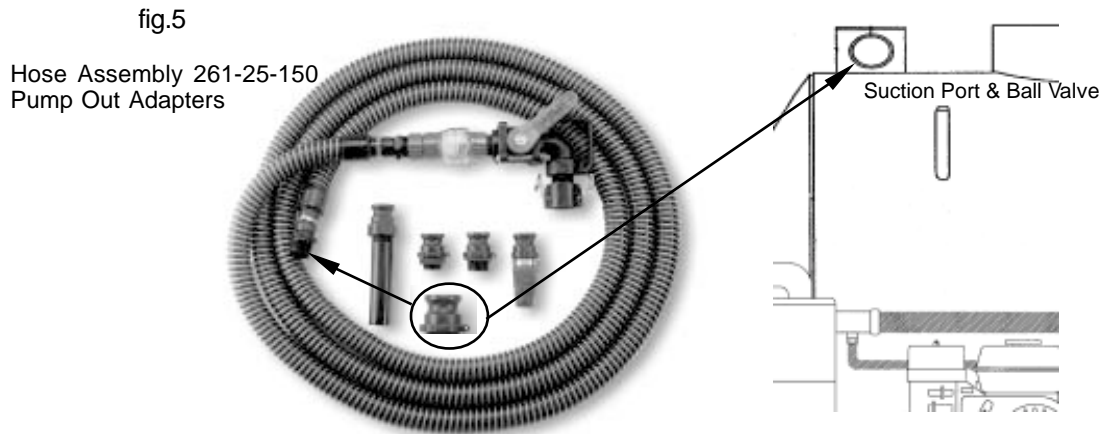

7. Pumping Operations 1st Time Start UP.

- Open all ball valves, any suction hose ball valves, the suction port ball valve at top of tank and the discharge port ball valve at bottom of tank.
- Pull out the slide valve handle to the vacuum position.
- Start engine. (See engine instruction manual.)
- Close discharge ball valve.
- Close suction hose ball valve. Gauge should show vacuum building inside tank.
- Open suction ball valve. Gauge should return to 0.
- Close suction ball valve and open discharge valve.
- Push slide valve in to pressure position.
- Close discharge ball valve. Gauge should show pressure building inside of tank.
- Open discharge ball valve. Gauge should return to 0.
- Shut off engine.

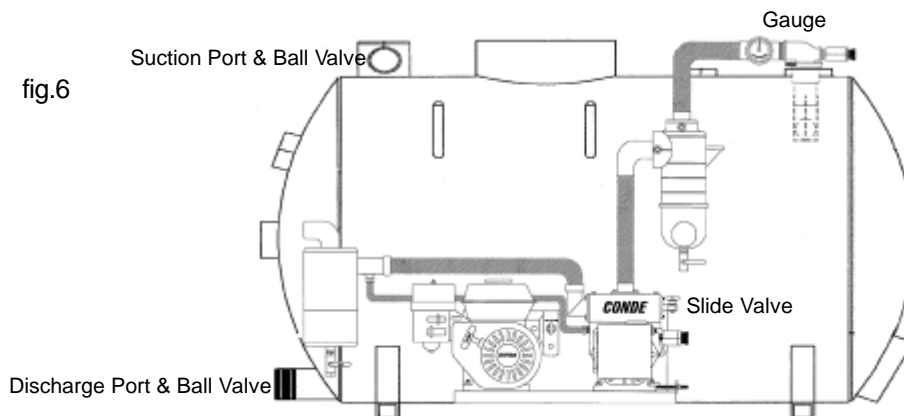

8. Pumping Operations - 2nd Time Start Up Pump Only Water.

- Pull out the slide valve handle to the vacuum position.
- Close tank discharge ball valve and open tank suction ball valve.
- Start engine.
- Close suction hose ball valve. Gauge should show vacuum building inside tank.
- Put suction end of hose into available water source.
- Open suction hose ball valve and water should begin to flow up the hose and into the tank.
- Fill the tank till water shows in 1st level sight port on tank.
- Close suction ball valve before water in tank reaches 2nd sight port.
- Close tank suction ball valve and open discharge ball valve.
- Push slide valve handle in to pressure position and tank will begin to empty through the discharge ball valve.
- When tank is empty, shut off engine and close discharge ball valve.
- Do this a few times until you are comfortable with the way the system works.

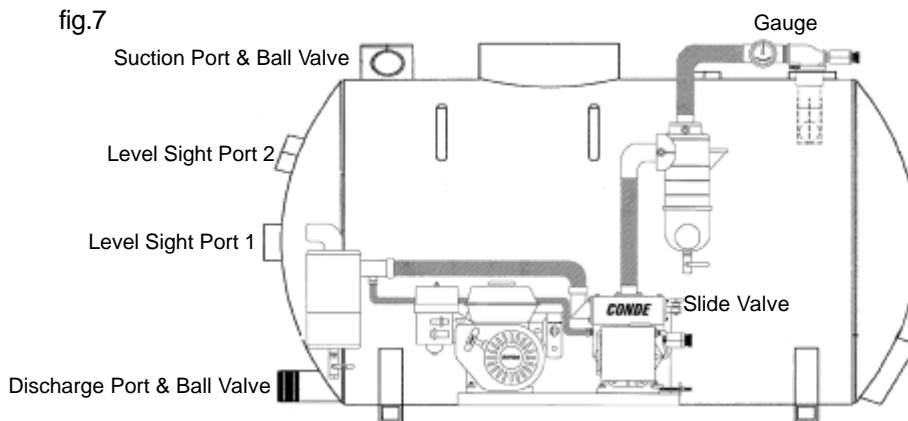

9. Pumping Out A Boat:

- Remove the waste deck cap on the boat.
- If the thread on the cap is the same size as one of the two waste deck adapters, screw the adapter that fits into the deck fitting. If neither one fit, attached the pump out nozzle to the end of the pump out hose.
- Unwind the pump out hose all the way.
- Turn on the vacuum system in the vacuum position.
- Clamp the pump out hose to the deck adapter or press the nozzle into the deck fitting.
- Open 1 1/2" 90° ball valve slowly.
- When pump out is complete, flush boat toilet with fresh water into holding tank and pump out again.
- Disconnect and rewind hose.
- Turn off pump and now close the pump out hose 90° ball valve.
- Wash up.

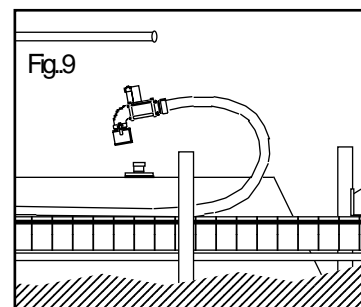
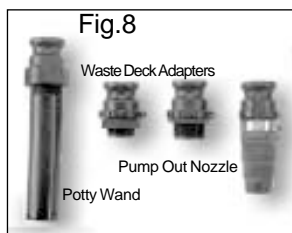

Parts

Vacuum Unit

Qty.	Part No.	Description
1	OL03RV	Conde Model 3 Radial Vane Pump
1	MT2E	Honda 2.5 Pull Start engine
1	GRDBO3	Belt Guard
1	SVO07	Oil Dripper
1	BASE03D	Pump Base
4	V1100	Vibration Isolators
1	EDMPOL	Pump Exhaust Hood
1	PULAK7434	Drive Pulley, Pump
1	PULAK3958	Drive Pulley, Engine
1	BLTA41	41 " A belt
1	T003ED	Oil Reservoir
1	SV122	Oil Reservoir Fill Plug
1	SV120	Oil Reservoir Fill Plug O-Ring
1	PFCVB018	1/8" brass check valve
2	RVPIO	Brass 3/4" relief valve (one for vac, one for press)
1	MFOC03	Oil Catch Muffler
1	GAGE016	Liquid Filled Vacuum/Pressure Gauge
1	LWTRO2	Plastic Secondary Moisture Trap
1	LWTR30	Primary Shut off
1	SV001	Slide Valve Plunger Assembly Complete
2	SV006	Slide Valve Piston Cup
1	SV011	Slide Valve Gasket
2	LWVG30	3" Sight Glasses
1	LVIVK300	3" Knife Valve
20'	LWHP20	2" Suction/Discharge Hose w/ two F adaptors
1	KIT03VOR	Maintenance Kit - Model 3 Radial

Hose Assembly 261-25-150

Qty.	Part No.	Description
1	262-25-150	Hose
1	269CL-150	Clear Swing Check Valve
1	264-90-150	90 Degree Ball Valve 1.5"
1	152FM-150NY	Quick Clamp Adapter 1 1/2" FQC X MNPT
1	158MF-150NY	Quick Clamp Adapter 1 1/2" MQC X FNPT

Pump Out Adapters

Qty.	Part No.	Description
1	273-150	1 1/2" Deck Adapter
1	273-125	1 1/4" Deck Adapter
1	272QC-150	QC Pump Out Nozzle
1	274-150	Potty Wand

Clean and Maintenance

- The easiest way to keep the inside of the Pumpout Unit tank clean, is to pump water with a degreaser into the tank using the hose attachment. In this way, all parts of the unit that are normally exposed to waste are cleaned by the water/degreaser. Immediately after filling the tank with water, off-load the unit as previously explained into an appropriate container.
- Your Pumpout Unit is equipped with a 12" quick disconnect manway located on the top of the tank. This 12" manway provides access to the inside of the tank to remove any debris that might have been sucked into the unit. It is also possible to use the 12" opening to spray out the unit.

Oil Reservoir

IMPORTANT
Fill Vacuum Pump Oil Reservoir With 10W30 High Detergent Oil Before Starting System.
Failure to Do So Will Cause Damage to The Model 03 Vacuum Pump.
For fill location see fig 1, item 14 page 2 of this manual.

- **Check Oil Level Regularly** - Refill when oil level drops to 1/4 full. Add oil as required to maintain level.

Moisture Traps

- **Visual Check Daily**- The Edson unit is equipped with a primary ball and cage shut off which is built into the tank. This primary shut off will shut off the vacuum line to the pump in the event of overfilling the tank. A secondary clear bowl moisture trap is installed on the tank to pump air line in case any moisture or waste gets past the primary shut off. This clear bowl trap should be checked periodically for moisture and drained accordingly. Though these two traps are designed to prevent liquid from reaching the air pump, they can not prevent it entirely. You can.
- **Avoid Overfilling the Tank** - Remember, the best defense against getting waste into the pump is to avoid overfilling the tank. Sight eyes are installed on the tank for the purpose of determining waste level within the tank. If it is thought that any waste has been sucked into the pump, immediately flush pump with kerosene or fuel oil. (See Flushing Instructions).

Oil Catch Muffler

- **Drain Periodically**- The Oil Catch Muffler is designed to capture oil as it exits the exhaust of the pump. It is necessary to periodically drain the oil catch by turning the petcock located at the bottom of the Oil Catch Muffler. Always dispose of used oil in a responsible way. Do not put used oil from the Oil Catch Muffler back into the Oil Reservoir.

Air Pump Flushing Instructions

- **As Required** - The air pump is a combination vacuum/pressure pump. It is built for years service. The only maintenance required is to keep the oil reservoir full so that the pump does not run dry. If the air pump rotor or vanes becomes locked up or if the tank overfills and liquid gets into the pump, it will be necessary to flush the vane chamber with kerosene. **Never under any circumstance flush out the pump with gasoline or any other highly flammable substance.**
- **To Flush the Pump**- Use the brass flushing petcock located on the front of the pump. Attach a small line from the petcock to a small can of kerosene. Turn the pump on in the vacuum or suction mode, and open the petcock. Even though the vanes inside the pump may be stuck in the rotor slots, a small amount of vacuum should draw kerosene into the pump and out the exhaust. Continue to suck kerosene into the pump until the vanes become free which can be audibly detected, and the pump is of the oil catch muffler and turn the unit back on in the vacuum mode to make sure the pump is receiving the proper amount of oil via the oil dripper. Note: Serious corrosion problems caused by liquid or other foreign substance entering the pump may require complete disassembly and rebuilding of the pump. See Air Pump Manual.

Trouble Shooting

Problem

Unit turns on, but will not build up vacuum.

Unit builds vacuum, but will not pump.

When unit is turned on, engine bogs down and pump does not turn.

In the pressure mode, unit builds pressure, but will not off-load

Slow/No drip inside oil dripper

Pump is overheating

Solution

Check to see that all valves are closed, including pump flush valve.

Hose is clogged with debris. Turn unit off, detach suction line and reattach turning it end for end. Turn on unit in vacuum mode to dislodge debris.

Pump has sucked liquid or water into it. Flush out unit per flushing instructions.

Pump may have been running without oil. Check oil.

Make sure the discharge line is open. Detach hose and reverse it end for end in the event the hose is clogged.
Make sure the off-load head is not more than 10'.

Oil tank is low. Fill up oil tank.

Pump is not getting sufficient oil. Adjust oiler.