



1HP VACUUM PUMPING EQUIPMENT 290 2210

Installation and Operations Manual

Index

Page 1 Description	Page 13 Operation
Page 2 Components & Dimensions	Page 15 Part
Page 4 Installation:Guidelines	Page 17 Maintenance
Page 7 Installation:Electrical	Page 18 Trouble Shooting

The Pump Unit & Components

290 2210 - Is built with a Model 03, rotary vane, oil protected, 20 cfm air pump driven by a 1 hp electric motor with an automatic discharge control system. This vacuum system will develop 23" hg of vacuum (25 ft of suction lift) and 10 psi (23 ft of discharge head) and automatically cycle from vacuum to pressure when the transfer cell is full. The transfer cell is an intergral component and can be one of a variety offered by Edson. The standard transfer cell is the Model 290-35. It is a 35 gallon capacity stainless steel vessel designed to work with this vacuum unit. Optional components include different transfer cells, a hose, hose stands and hydrants and remote start stop switches.



ATTENTION
 Fill Oil Reservoir Before Starting.
 See Page 3 for Information.

ENTER YOUR VACUUM PUMP DATA HERE

SYSTEM SERIAL #

From Edson Serial # Sticker On Vacuum Pump Mounting Frame

VACUUM PUMP

Motor



Pump Unit Details & Dimensions

- 1.) Pump Unit Stand
- 2.) Cover
- 3.) Control Panel with Key Switch Motor
- 4.) 4 Way Valve
 - 4a. Tank Air Line Port
 - 4b. Vacuum Exhaust Line Port
- 5.) Air Filter
- 6.) Vacuum Regulator
- 7.) Pressure Regulator
- 8.) Model 03 Air Pump
- 9.) Oil Reservoir
- 10.) 1hp/1ph/115v/60hz/tefc
- 11.) Stand Mounting Holes

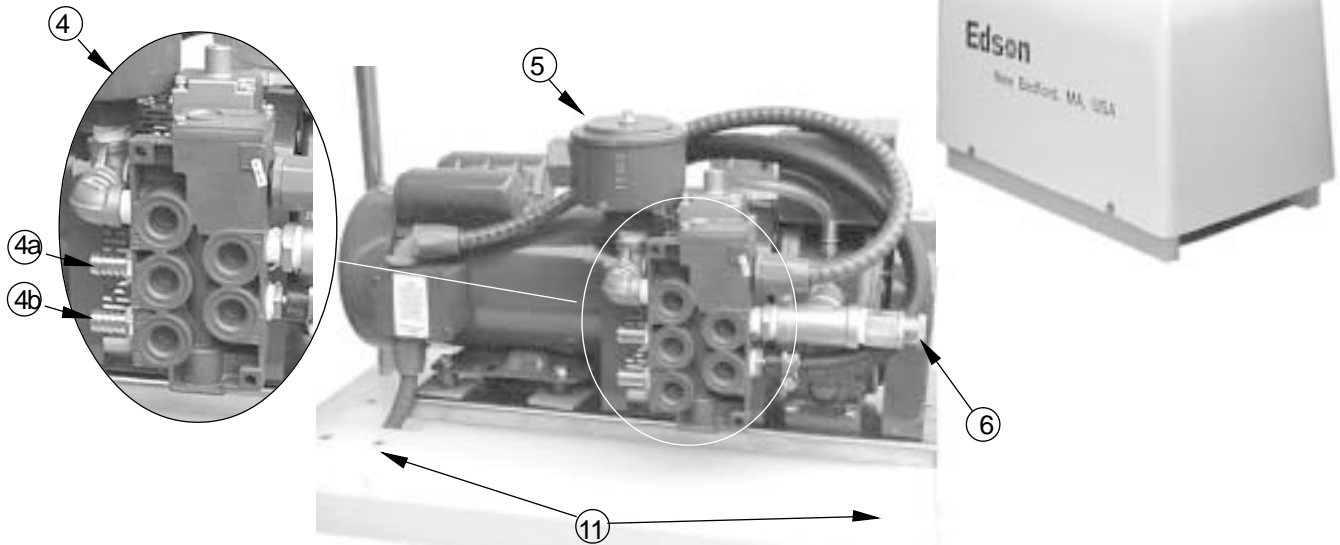

IMPORTANT

Fill Air Pump Oil Reservoir With Biodegradable Hydraulic Oil (Mobil EAL 224H) or 10W30 or 10W40 High Detergent Oil Before Starting System.

Failure to Do So Will Cause Damage to The Model 03 Vacuum Pump.

Fill Location - Oil Reservoir - Remove Fill Cap - Capacity 1 Qt.

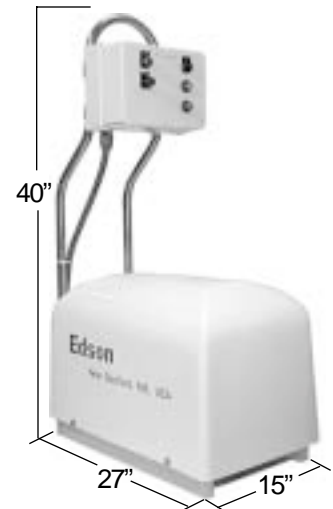
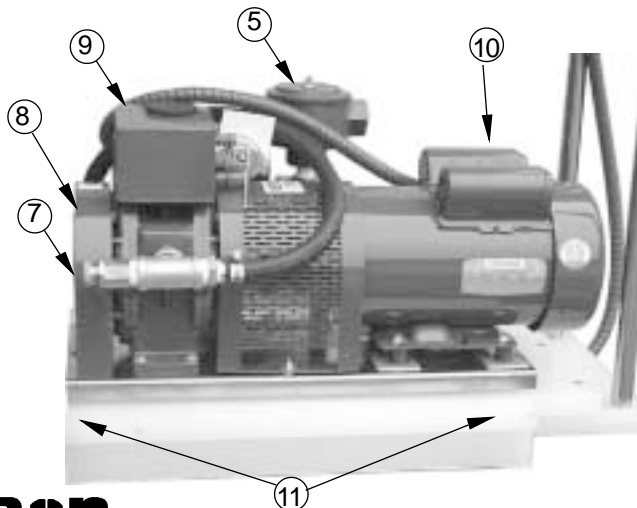

Transfer Cell Details & Dimensions

- 1.) Tank Air Line Connection
- 2.) Secondary Trap & Air Line Connection
- 3.) Primary Trap (inside tank)
- 4.) Tank Vacuum/Pressure Gauge
- 5.) Float Switch With Cord (inside tank)
- 6.) Suction Port Plumbing Assembly
 - a. Ball Valve
 - b. Check Valve
- 7.) Vacuum Exhaust Check Valve & Plumbing
- 8.) Discharge Port Plumbing
 - a. Ball Valve
 - b. Check Valve
- 9.) Air Line Hose

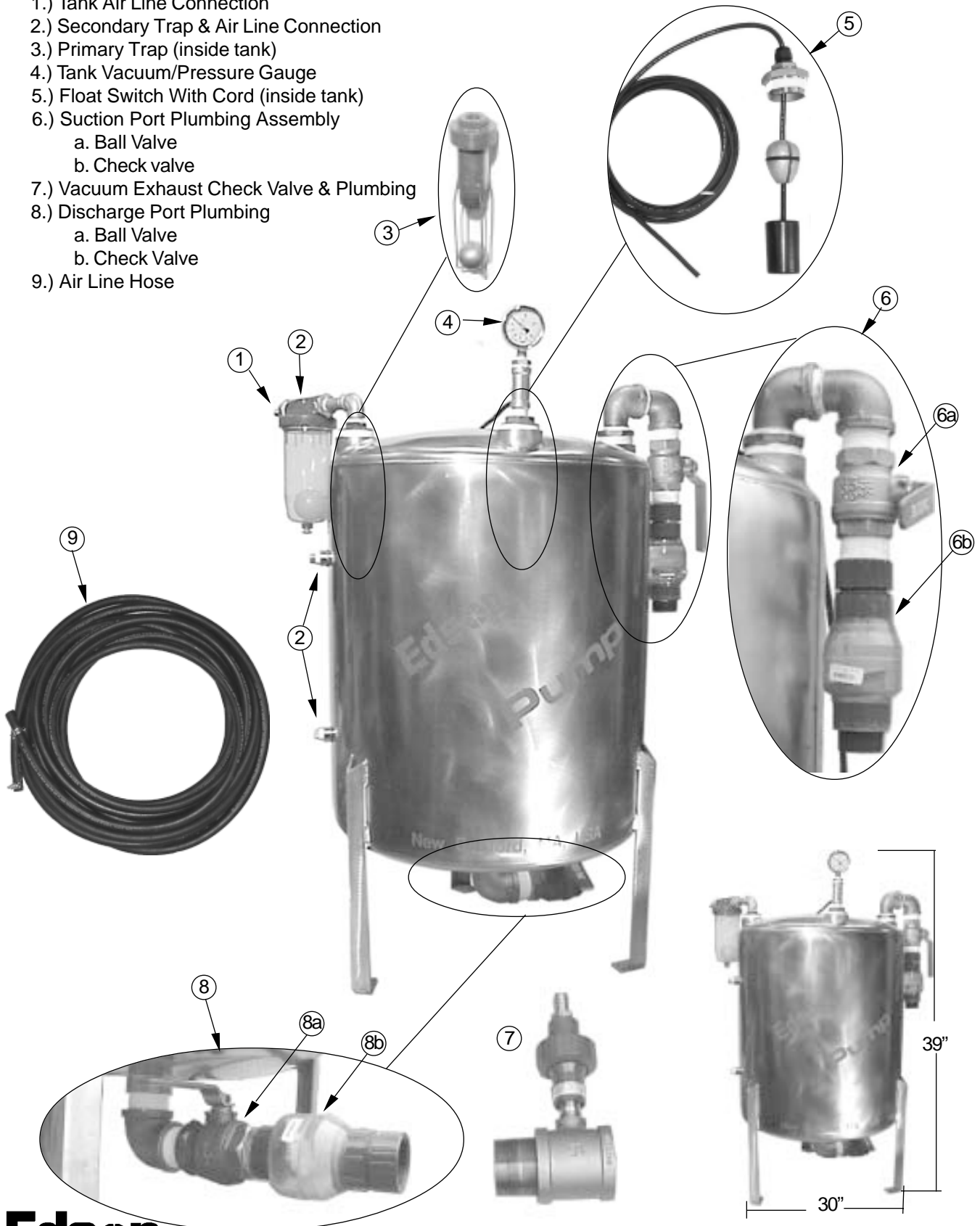

Installation Guidelines

WARNING

It is the responsibility of the purchaser to have the electrical service installed by a licenced electrician in accordance with the power requirements of the motor, the electrical service available and local electrical codes.

Failure to have the electricity installed correctly will result in damage to the pump and potential bodily injury, loss of life and property damage from electrical shock and fire.

CAUTION

Use Biodegradable Hydraulic Oil or High Detergent 10W-30 or 10W-40 Motor Oil Only
Using the wrong oil or dirty oil can cause loss of vacuum or pump failure.

1. Fill Oil Reservoir with A Biodegradable Hydraulic Oil (Mobil EAL 224H) or Any High Detergent 10W-30/40 Motor Oil

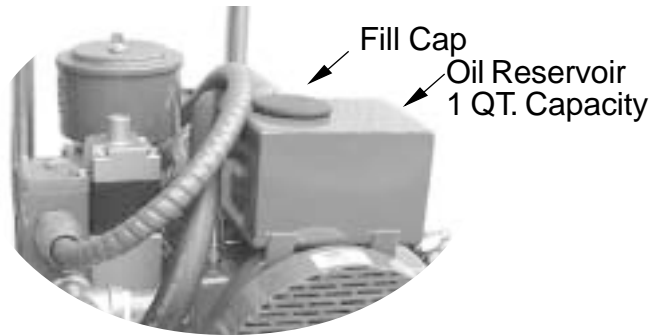

Bolt

ATTENTION

All Plumbing Fittings Must Be Air Tight. Installed With Thread Sealant.

2. Install Discharge Outlet and Suction Inlet Fittings to Tank

Tank Discharge Outlet
All 2" NPT Fitting

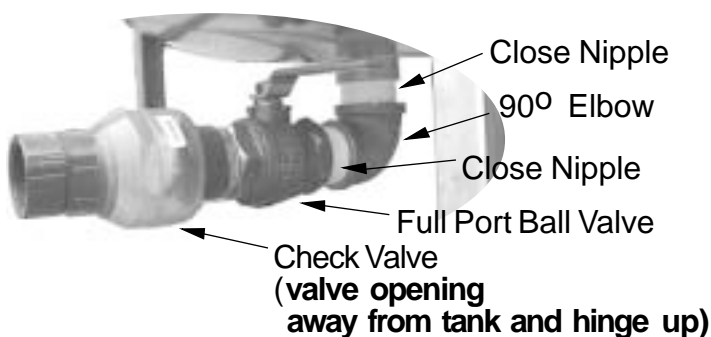

Suction Inlet
All 1½" NPT Fitting

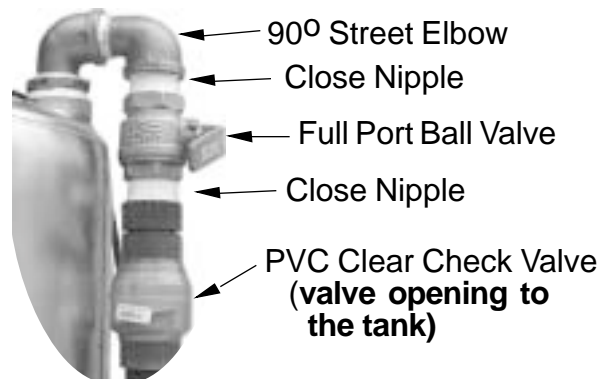

3.Guidlines for Locating and Installing Pump Unit, Tank

- a. The pump unit and tank can be separated by up to 50 feet or more.
- b. The pump and the tank must be located so the air hose and float switch cable can be connected between the two.

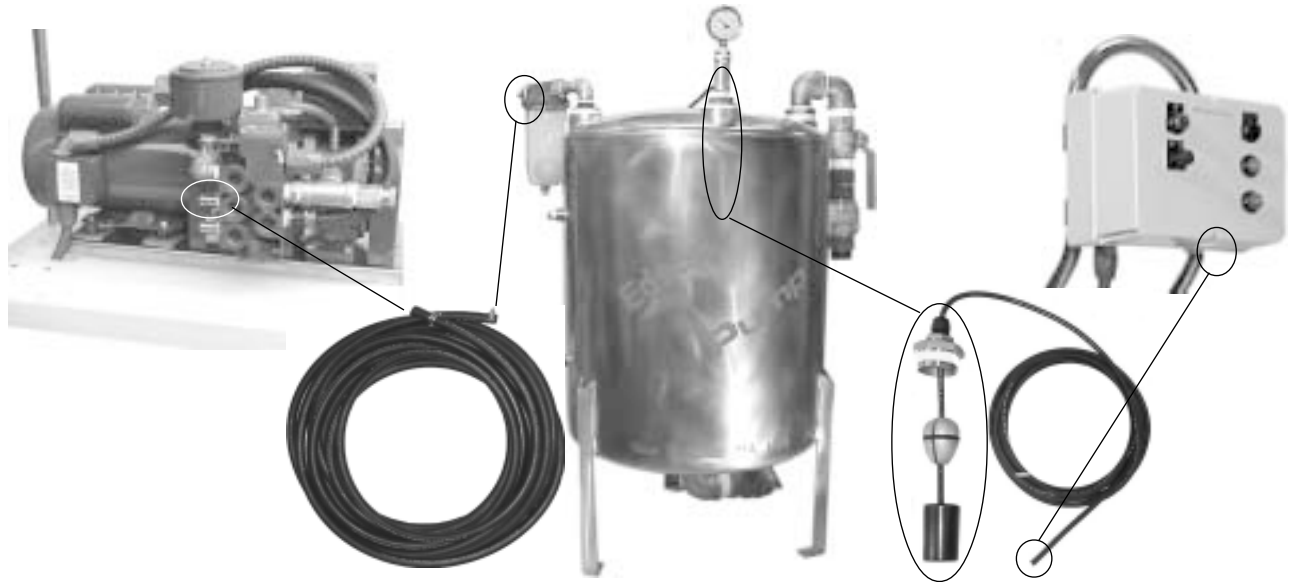

- c. The pump unit should be located under cover.
- d. If possible, it is preferred that the tank should be located so it will drain into the sewer line.
- e. Pump out locations can be up to 2000 feet from tank and pump unit. However remote start/stop stations operating on the standard 24 volt should not be installed more than 300 feet from the pump unit.
- f. Install the pump unit in accordance with the performance specification.

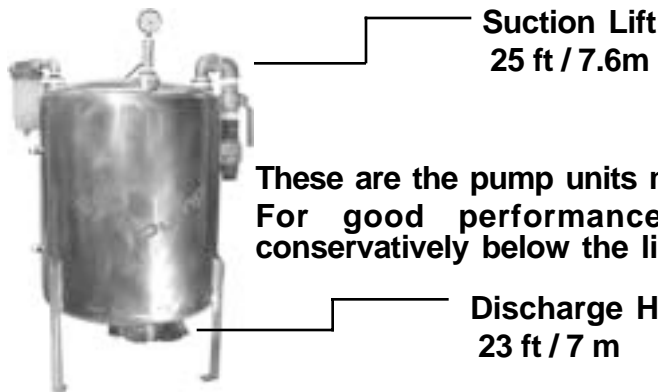

These are the pump units maximum performance limits. For good performance and long life, remain conservatively below the limits.

- m. Bolt the pump unit and tank to a secure surface.

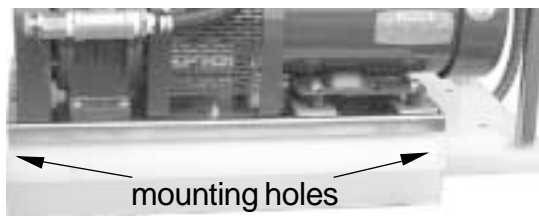

4.Guidlines for Controlling Vacuum Exhaust (Optional)

When the pump unit is in the vacuum mode the pressure side of the air pump is being exhausted through the lower port on the output side of the 4way valve.

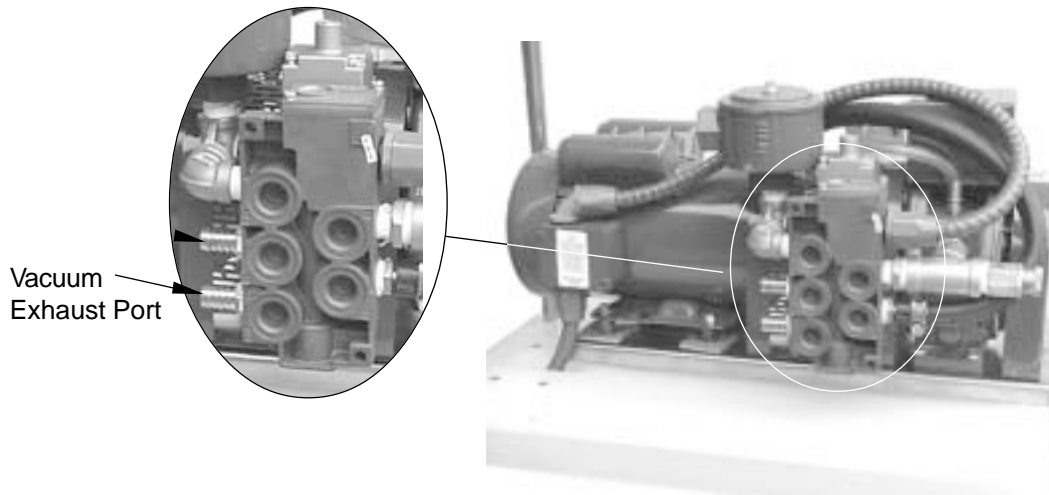

The air pump is an oil protected vane type and small amount of oil is being discharged with the exhaust air. Also, the liquid being vacuumed into the tank may smell or have characteristics that should not be discharged direct to atmosphere.

- a. Option One - If the liquid being pumped is free of odor and contaminants then simply plumb the exhaust port using the air hose into a drain or into an oil catch (order part # A-Oil Catch 1 HP) with the system. This is a small oil separator and can be plumbed outside the cover.
- b. Option Two - If the liquid being pump has a noxious smell then plumb the exhaust port directly into a sealed drain or out side the building. If there is any possibility of back pressure on this discharge line, install the Plast-O-Matic Check Valve shipped with the unit, to prevent back flow into the 4way valve. For **negative** discharge head installations connect the exhaust port to the tank discharge line just after the check valve. Use a section of vacuum/ pressure air line and the 1/2" check valve together with the 2" X 1/2" tee, 1/2" close nipple and 1/2" hose barb supplied with the unit to make the connection. fig 10. For installations with a **positive** discharge head the exhaust port air line must be connected at a point where the discharge line will gravity drain. Use the same plumbing connection and the check valve. . Use 1/2" pipe or hose for exhaust line.

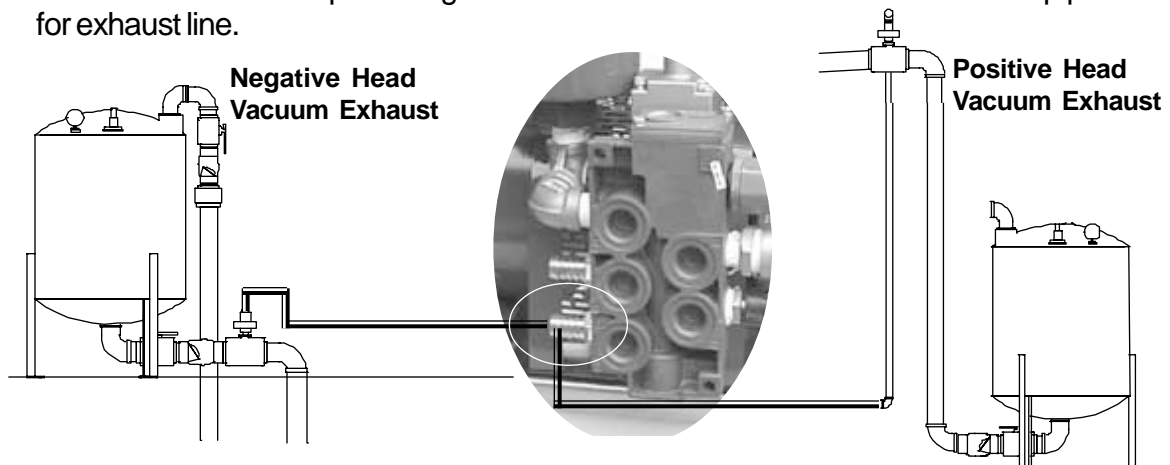

5.Guidlines for Electrical Installation -

IMPORTANT

This VacuMaster Requires 115 Volt, Single Phase, 60 HZ Electrical Service.
The 1 HP Motor Operating On 115V Is Rated At 12.8 Full Load AMP.

- a. Connect normally open float switch wires to control panel at terminal strip 7 & 8.
- b. Connect power lines to L1 & L2 on the terminal strip.
- c. Wire remote start/ stop stations. (Hose Stands and/or Remote Box)



Control Panel



Remote Station



b. Description Of Electrical Operation:

Key Switch On - Closes L1 and Powers the panel.

Press Green Start Switch To Start Automatic Cycle:

M1 Contact Energized and Motor Starts

4 Way Valve Energized (Vacuum Mode)

Timer Energized (Factory Set for 10 Min. Run Time)

Float Switch Closes (Goes into horizontal position)

T2 Timer Energized - Factory Set Time 25 Sec.

4 Way Valve Off (Pressure Mode)

Float Switch Opens (Goes into vertical position) & T- 2 Timer Times Out

4way Valve Energized (Vacuum Mode)

(above will continue until T1 Timer times out or the Stop Switch is pressed.)

Press Stop Switch - De-energizes all Contacts and Relays.

Press Black Momentary (Pressure) Switch

M1 Contact Energized and Motor Starts

T1 Timer Energized and Run Time Starts (Set at factory 0-10 Minute Mode)

4 Way Valve Stays Off. (Pressure Mode)

c. Timers: Settings and Function

T1 Timer - TM1 Motor Timer acts as a self-monitoring Shut-Off for the motor. The T switches on the front are factory set at 1 & 0 which allows for .01 min to 10 minute run time It can be reset up to 10 hrs. See data sheet below or chart on the side of the timer.

T2 Timer - TM2 4way Valve Timer sets the time the 4way valve is in the pressure mode after it automatically switches from vacuum when the transfer tank is full. It is factory set for 25 sec. before the system will automatically switch back to vacuum. See data sheet below or chart on the side of the timer.

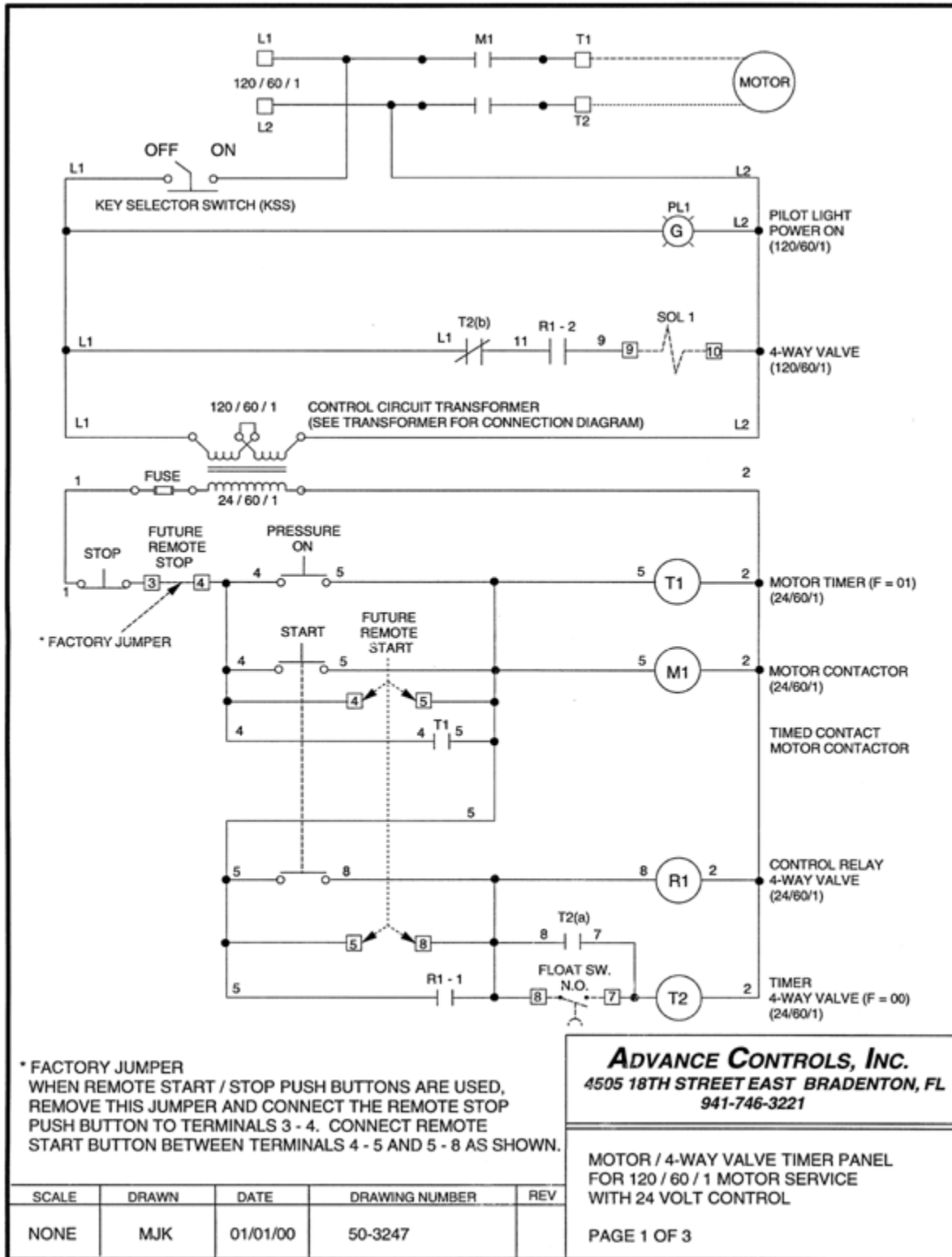

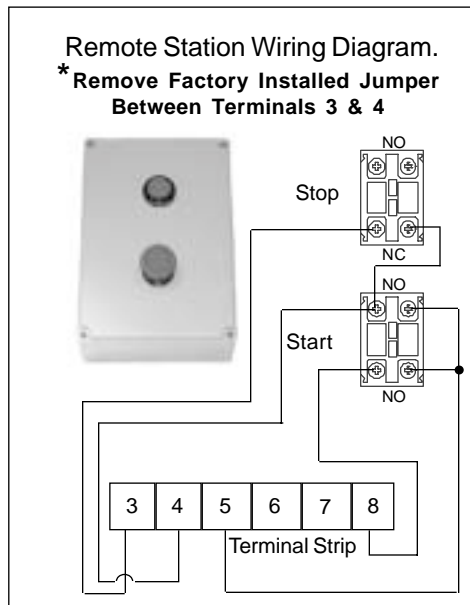
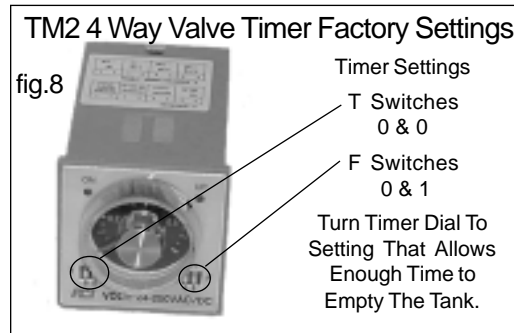
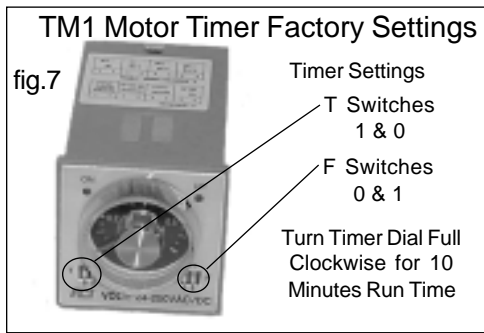

Note: 4 wires are being used to wire the remote stations to the main panel terminal strip.

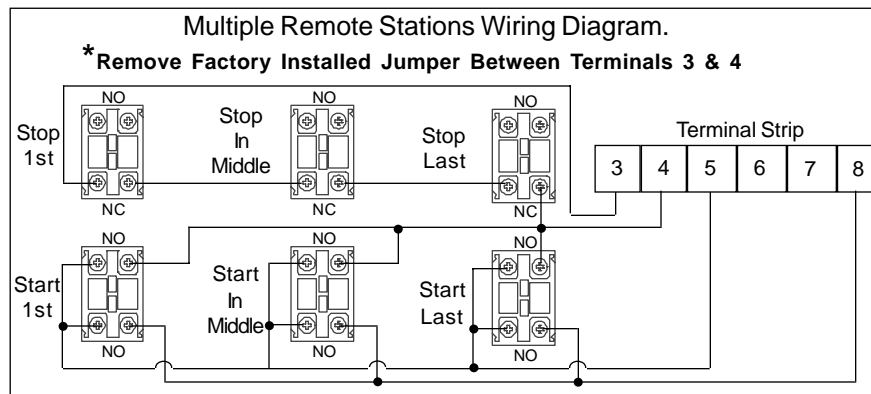

GENERAL LAYOUT OF ENCLOSURE BACK PLATE

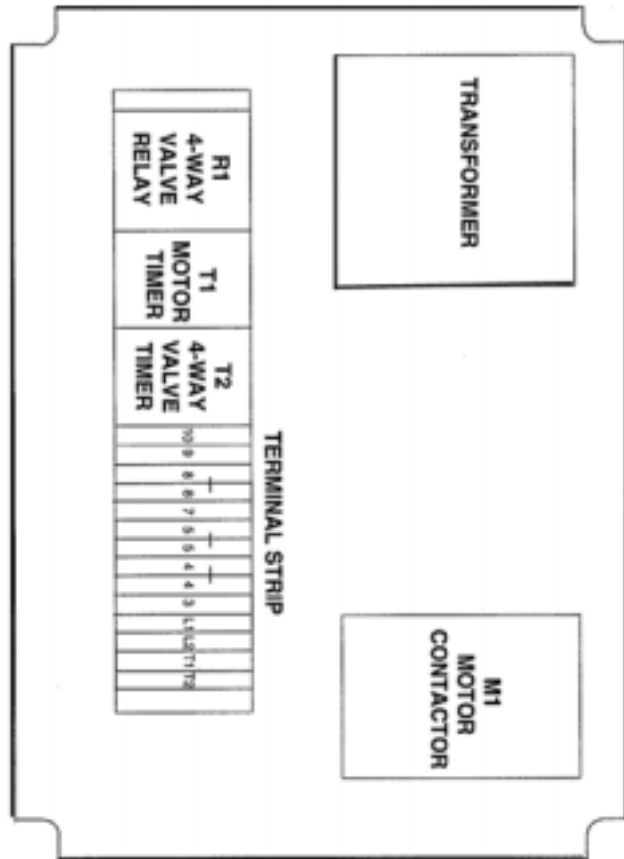

SCALE	DRAWN	DATE	DRAWING NUMBER	REV	ADVANCE CONTROLS, Inc. 4505 18TH STREET EAST BRADENTON, FL 941-746-3221 MOTOR / 4-WAY VALVE TIMER PANEL FOR 120 / 60 / 1 MOTOR SERVICE WITH 24 VOLT CONTROL
NONE	MJK	01/01/00	50-3247		

PAGE 2 OF 3

GENERAL LAYOUT OF ENCLOSURE COVER

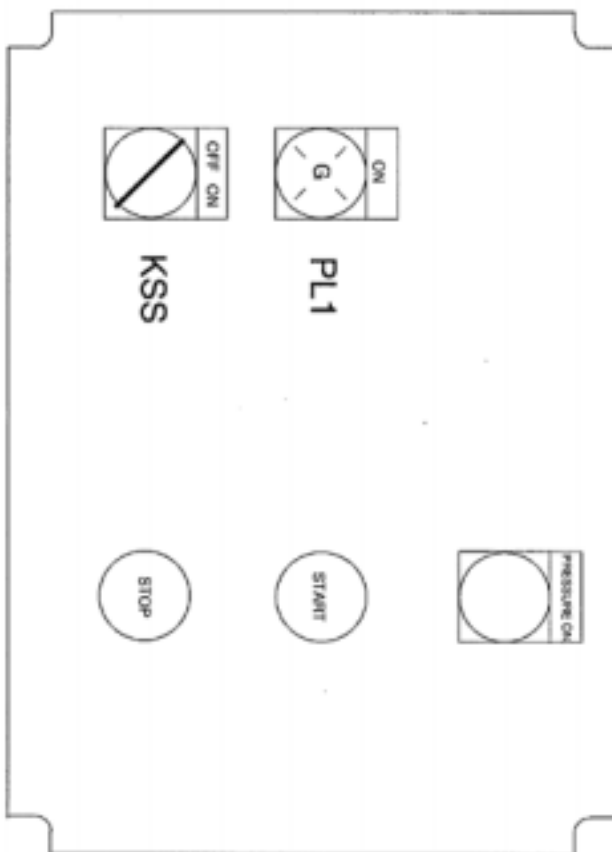

PAGE 3 OF 3

SCALE	DRAWN	DATE	DRAWING NUMBER	REV
NONE	MJK	01/01/00	50-3247	

ADVANCE CONTROLS, Inc.
 4505 18TH STREET EAST BRADENTON, FL
 941-746-3221
 MOTOR / 4-WAY VALVE TIMER PANEL
 FOR 120 / 60 / 1 MOTOR SERVICE
 WITH 24 VOLT CONTROL

85 SERIES TIMER • MULTI FUNCTION/RANGE/VOLTAGE

ADVANCE CONTROLS' 85 SERIES MULTI FUNCTION/RANGE VOLTAGE TIMERS OFFER A CHOICE OF FOUR (4) TIMING FUNCTIONS, FOUR (4) TIMING RANGES, AND A WIDE RANGE OF INPUT VOLTAGES



MULTI FUNCTION: WITH THE PROPER SETTING OF THE "F" (FUNCTION) DIP SWITCH, THIS ACI TIMER CAN FUNCTION EITHER AS AN ON DELAY, REPEAT CYCLE, INTERVAL (REVERSE ON DELAY) OR A REVERSE REPEAT CYCLE TIMER.

MULTI RANGE: WITH THE PROPER SETTING OF THE "T" (TIME) DIP SWITCH, THE ACI TIMER OFFERS A CHOICE OF FOUR (4) TIMING RANGES (0.05 / 1 SEC : 0.12/10 SEC: 0.6 SEC/1 MIN: 6 SEC/10 MIN. OR 0.05/1 MIN: 0.12/10 MIN: 0.6 MIN/1 HOUR: 1 MIN/10 HOUR).

WIDE RANGE INPUT VOLTAGE: A WIDE RANGE OF INPUT VOLTAGES ARE ALLOWED (24 VAC/VDC THROUGH 240 VAC/VDC, 50/60 HZ) WITHOUT WIRING CHANGES OR DIP SWITCH SETTINGS.



THE FEATURES OF THE ADVANCE CONTROLS TIMER MINIMIZE INVENTORY WHILE MAXIMIZING THE BENEFITS FOR TIMER APPLICATIONS.

CATALOG NUMBERS / TIME RANGES

CATALOG NUMBER	MODEL NUMBER	OUTPUT	TIMING RANGE	DIP SWITCH "T" (TIME RANGE) SETTING				LIST PRICE
				0 0	1 0	0 1	1 1	
104214	8511A240	11 PIN	SEC [s] - MIN [m]	0.05s - 1s	0.12s -10s	0.6s-1m	6s-10m	\$ 64.00
104216	8521A240	DPDT	MIN [m] - HOUR [h]	0.05m - 1m	0.12m-10m	0.6m-1h	1m-10h	64.00
104217	8542A240	8 PIN	SEC [s] - MIN [m]	0.05s - 1s	0.12s-10s	0.6s-1m	6s-10m	62.00
104218	8552A240	SPDT	MIN [m] - HOUR [h]	0.05m - 1m	0.12m-10m	0.6m-1h	1m-10h	62.00

FUNCTION CHART

FUNCTION	DIP SWITCH "F" (FUNCTION) SETTING	DESCRIPTION
"ON" DELAY	0 0	TIMING BEGINS WHEN POWER IS APPLIED TO THE UNIT. THE OUTPUT CONTACTS TRANSFER WHEN THE TIME DELAY SETTING IS REACHED TO RESET THE TIMER. REMOVE THE INPUT POWER OR OPERATE THE CUSTOMER SUPPLIED EXTERNAL "RESET" SWITCH.
REPEAT CYCLE	1 0	TIMING BEGINS WHEN POWER IS APPLIED TO THE UNIT. THE OUTPUT CONTACTS TRANSFER WHEN THE TIME DELAY SETTING IS REACHED. THE OUTPUT CONTACTS REMAIN TRANSFERRED UNTIL THE TIME DELAY SETTING IS AGAIN REACHED. THE OUTPUT CONTACTS ARE THEN RELEASED AND RETURN TO THE ORIGINAL STATE. THE TIMER THEN AUTOMATICALLY RESETS AND REPEATS THE TIMING CYCLE UNTIL THE INPUT POWER IS REMOVED.
INTERVAL (REVERSE ON DELAY)	0 1	APPLYING POWER TO THE TIMER IMMEDIATELY TRANSFERS THE OUTPUT CONTACTS AND TIMING BEGINS. ONCE THE TIME DELAY SETTING IS REACHED, THE OUTPUT CONTACTS ARE RELEASED. THE TIMER IS RESET EITHER BY REMOVING THE INPUT POWER OR OPERATING THE CUSTOMER SUPPLIED EXTERNAL "RESET" SWITCH.
REVERSE REPEAT CYCLE	1 1	APPLYING POWER TO THE TIMER IMMEDIATELY TRANSFERS THE OUTPUT CONTACTS AND TIMING BEGINS. THE OUTPUT CONTACTS REMAIN TRANSFERRED UNTIL THE TIME DELAY SETTING IS REACHED. THE OUTPUT CONTACTS ARE THEN RELEASED AND WHEN THE DELAY SETTING IS AGAIN REACHED, THE OUTPUT CONTACTS TRANSFER AND REMAIN TRANSFERRED UNTIL THE TIME DELAY SETTING IS AGAIN REACHED. THE TIMER CONTINUES TO AUTOMATICALLY REPEAT THE CYCLE UNTIL THE POWER IS REMOVED.

RESET SWITCH: RESETS THE TIMER TO ZERO. REQUIRES CUSTOMER SUPPLIED MOMENTARY SWITCH.

MEMORY SWITCH: PAUSES THE TIMING CYCLE AT THAT POINT IN THE CYCLE. WHEN RELEASED, IT ALLOWS THE CYCLE TO RESUME FROM THE SAME POINT. REQUIRES A CUSTOMER SUPPLIED MOMENTARY SWITCH.

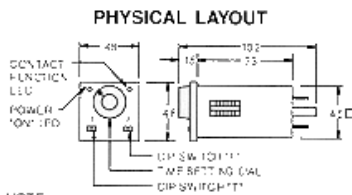

- NOTE:
- 1) SQUARE PANEL MOUNT ADAPTOR (DIN 48 MM) AVAILABLE FOR SNAP MOUNTING INTO A PANEL CUTOUT
 - 2) ALL DIMENSIONS ARE IN MILLIMETERS (INCHES = MM/25.4)

CONNECTION DIAGRAM

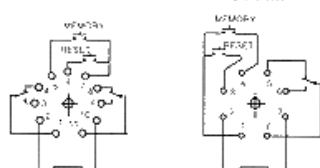

INPUT VOLTAGE: 24 - 240 VAC/VDC 50-60 HZ

SOCKET: ZVR11 OR ZVD11 SOCKET: ZVR8 OR ZVD8

SPECIFICATIONS

INPUT VOLTAGE: 24-240 VAC/VDC 50/60 HZ
 CONTACT RATING: 10A/250 VAC 10A/30 VDC
 MOUNTING: 8 OR 11 PIN OCTAL BASE

INPUTS: POWER,
 MEMORY (OPTIONAL),
 RESET (OPTIONAL)

ELECTRICAL LIFE: 250,000 CYCLES

REPEATABILITY: +/- 1%

SETTING TOLERANCE: +/- 10%

RESET TIME: 0.1 SEC MAX

OPERATING TEMP:

+15 +120 DEG. F (-10 +50 DEG. C)

OPERATING HUMIDITY: 85% RH MAX

IMPORTANT

**All Testing Should Be Carried Out Using Available Clean Water.
Do Not Pump Waste Liquids Until You Are Sure Unit Is Operating Properly**

Pump Unit Test:

1. Turn Key Switch On:

- Green light on front of enclosure comes on.
- Power is on to start/stop and pressure switches on enclosure and start/stop switches on remote stations.

2. Press Any Green Start Switch:

- Motor starts and drives the air pump.
- 4way valve is turned on so that vacuum side of the air pump connects to the tank depressurizing the tank.
- A small amount of oil from the reservoir is drawn into the pump lubricating it.
- With the tank check valves in place and the ball valves open vacuum should be felt on the inlet side of the tank but the tank gauge will read zero.
- Close the inlet ball valve and watch the pressure/vacuum gage. The gauge should record vacuum (Hg) pressure. Open the inlet ball valve and the gauge should drop back to zero.

REGULATORS HAVE BEEN FACTORY SET AT 15" HG VACUUM AND 10 PSI PRESSURE

- Press the red stop button to stop the motor and turn off the 4way valve or let the unit run till the TM1 timer times out and the motor turns off automatically.

3. Press Any Red Stop Switch With The Motor Running:

- Motor stops and 4way valve turn off.

4. Press Black Pressure Switch:

- Motor starts and drives the air pump.
- The 4way valve stays off. The pressure side of the air pump is open to the tank.
- A small amount of oil from the reservoir is drawn into the pump lubricating it.
- With the tank check valves in place and the ball valves open pressure should be felt on the discharge side of the tank but the tank gauge will read zero.
- Close the discharge ball valve and watch the pressure/vacuum gage. The gauge should record pressure (psi). Open the discharge ball valve and the gauge should drop back to zero.
- Press any red stop button to stop the motor or let the unit run till the TM1 timer times out and the motor turns off automatically.

5. Float Switch Controls The Automatic Switching of The Pump Unit From Vacuum to Pressure:

- Press any green start switch and vacuum clean water into the tank.
- When tank is full float switch will go horizontal. This turns off the 4way valve. The pressure side of the air pump is now connected to the tank and the pressure empties the tank through the discharge line.
- When the TM2 timer times out the 4way valve comes back on and the vacuum side of the air pump starts to depressurize the the tank again.
- This cycle will continue until the TM1 timer times out or any red stop switch is pushed.



Control Panel

6. Necessary For Good Pumping Operation:

- All electrical components operating properly.
- Pressure and Vacuum Regulators Set Properly (See Page 13)
- Tank inlet and discharge check valves installed correctly and sealing properly.
- Float switch positioned at correct height inside the tank.
- Suction and discharge plumbing air tight.

Setting Vacuum/Pressure Regulators:

WARNING

**Depressurize The System Before Removing Any Parts.
Never Adjust The Pressure Relief Regulator When The System Is On & There Is A Pressure Reading On The Gauge. The Adjusting Nut Could Blow Off And Cause Serious Injury**

1. Check regulator settings

- Regulators have been factory set at 15" hg vacuum and 10 psi pressure.
- Close the ball valves at the top and bottom of the tank. Run the VacuMaster in vacuum for 2 to 3 minutes and record the gauge reading. Then run the VacuMaster in the pressure mode for 2 to 3 minutes and record the gauge reading.

Tools:
Adjustable Crescent Wrench
Channel Locks

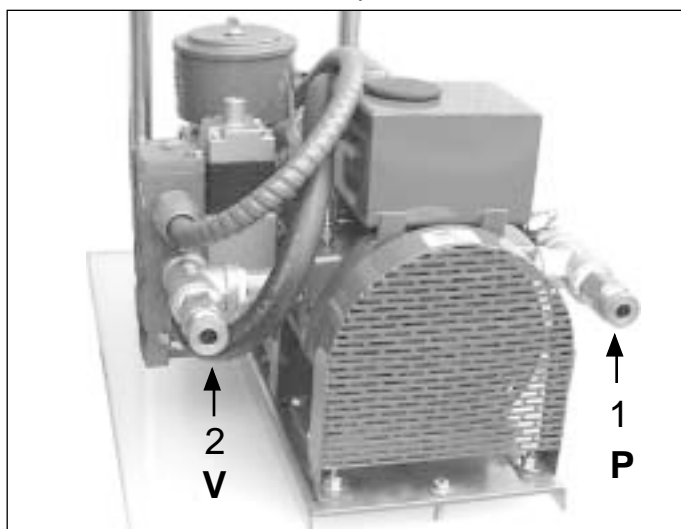

2. Reset regulators per the following instructions:

● Adjust Pressure Regulator 1

- Step 1 Close inlet and discharge ball valve.
Step 2 Run VacuMaster in the pressure mode. Record pressure reading, turn system off. **Allow Tank To Depressurize. Do Not Adjust Pressure Regulator With System On. Regulator Adjusting Screw Could Blow Loose and Cause Bodily Injury.**
Step 3 Loosen locking nut counter clockwise.
Step 4 If pressure setting is too low, turn knurled hub clockwise to increase pressure at which valve opens. If pressure is too high, turn hub counter clockwise.
Step 5 Tighten locking nut. Turn on system.
Repeat steps 2-5 until pressure is set.

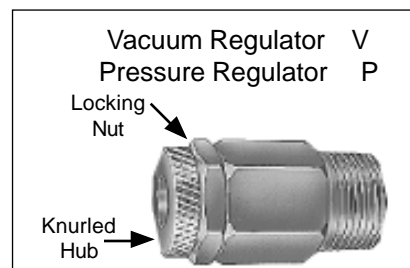

● Adjust Vacuum Regulator 2

- Step 1 Close inlet and discharge ball valve.
Step 2 Run VacuMaster in the vacuum mode. Record vacuum reading, turn system off. **Allow Tank To Depressurize. Do Not Adjust Pressure Regulator With System On. Regulator Adjusting Screw Could Blow Loose and Cause Bodily Injury.**
Step 3 Loosen locking nut counter clockwise.
Step 4 If vacuum setting is too low, turn knurled clockwise to increase pressure at which valve opens. If vacuum is too high, turn hub counter clockwise.
Step 5 Tighten locking nut. Turn on system.
Repeat steps 2-5 until vacuum is set.



Parts List

Key No.	Part No.	Description	QTY
Tank Assembly			
1	160-A-1421-A	Vinyl Sign - Edson New Bedford	1
2	160-A-1708-150	Nipple - 1-1/2 X Close - Brass	2
3	160-A-1708-200	Nipple, 2" x Close, Brass	2
4	160-A-1709-150	Ball Valve - 1-1/2 Full Port Bronze	1
5	160-A-1709-200	Valve, Ball, 2" Full Port, Bronze	1
6	160-A-1711-150	Street Ell 1-1/2" 90 Degree	2
7	160-A-1711-200	Elbow, 90' Street, 2" Bronze	1
8	160-A-2025	Trap, 1" NPT Poly Trap w/Ball	1
9	160-A-2055	Bushing, Reducer 2" x 1/2", Bronze	1
10	160-A-2074	Float Switch, Normally Open	1
11	160-A-2075	Weight, Float	1
12	160-A-2076	Tee, Reducer, 2" x 1/2", Bronze	1
13	160-A-2078	Hose Barb, 1/2" MNPT x 5/8", Brass	2
14	160-A-2080	Hose, 5/8"	25'
15	160-A-2081-SS	Plug, Hex Head, 1/2", Stainless	2
16	160-A-2119	Elbow, 90', 1/2" Stainless 150# TH	2
17	160-A-2120	Nipple, 1/2" x Close, Stainless	4
18	160-A-2121	Nipple, 3" x 1/2", 304 Stainless	1
19	160-A-2123	Bushing, Rudder 1" x 1/2", 304 SS	2
20	160-A-2125-.5	Check Valve, 1/2" Plast-o-matic	1
21	160-A-2127-SS	Bushing, 1/2" x 1/4" Reducer, SS	1
22	160-A-2131	Trap, Primary w/2" x 1/2" Reducer B	1
23	160-A-2197	Electrical, Strain Relief 1/2"	1
24	160-A-2254	Tee, 1/2" Stainless	1
25	160-A-939-BR	Bushing - Reducer - 2" x 1-1/2" Br	1
26	161-A-1824	Pressure/Vacuum Gauge	1
27	161-A-2240	VacuMaster 35 Gallon Stainless Tank	1
28	269CL-150	Check Valve/Sight Glass - 1 1/2" -	1
29	269CL-200	Check Valve/Sight Glass - 2" - Nitr	1
30	960-A-599-HS10	Hose Clamp HSS10 9/16 to 1-1/16 -	2
Pump Unit Assembly			
31	160-A-1253	Sealing Washer - Neoprene - Compact	4
32	160-A-1421-A	Vinyl Sign - Edson New Bedford	1
33	160-A-2078	Hose Barb, 1/2" MNPT x 5/8", Brass	4
34	160-A-2080	Hose, 5/8"	2
35	160-A-2118	Tee, 3/4" Stainless	2
36	160-A-2119	Elbow, 90', 1/2" Stainless 150# TH	2
37	160-A-2120	Nipple, 1/2" x Close, Stainless	4
38	160-A-2124	Bushing, Reducer 3/4" x 1/2" Stainl	2
39	160-A-2128	Conduit, Electrical, 3/8 Carlon Car	5'
40	160-A-2129	Conduit, Electrical Fitting, 90'	1
41	160-A-2130	Conduit, Electrical Fitting, 3/8"	3
42	160-A-2149	Nipple - 3/4" x Close 304SS Std	1
43	160-A-2197	Electrical, Strain Relief 1/2"	1
44	160-A-2236	Nipple, 3/4 x 3", 304 Stainless	1
45	160-A-2255-14GR	Electrical, 14 Gauge Wire, Green	15'
46	160-A-2255-14RD	Electrical, 14 Gauge Wire, Red	6
47	161-A-2013	VacuMaster - Pressure Relief Valve	2
48	161-A-2071	Pump #3, 1Hp 1Ph Direct Drive	1
49	161-A-2071FILTR	Filter, Cartridge Type, 1/2" NPT	1
50	161-A-2073	Valve, Numatic, 4 Way, 1/2"	1
51	161-A-2109	Electric Control Panel 2Hp 1Ph 120V	1
52	161-D-212	VacuMaster Pump Cover ONLY	1
53	710-95	Accessory Bracket - Stainless	2
54	960-A-599-HS10	Hose Clamp HSS10 9/16 to 1-1/16	4
55	960-C-59B	Guard Pipe	1
56	D-216	Vacuum Master Platform	1
57	F1/4-1-HH	1/4-20 x 1 SS HHCS	4
58	F1/4-2.5-HH	1/4-20 x 2-1/2 SS HHCS	2
59	F1032-3/4-PHP	10-32 x 3/4 SS PHMS Phillips Drive	4

Edson
INTERNATIONAL

Caution

Turn System Off At Main Power Source When Doing Any Maintenance That Requires Undoing Or Opening Parts Of VacuMaster. Failure To Lock Out Power Could Result In Injury.

Maintenance Schedule:

1. Daily When In Use:

- **Flush tank with fresh water.**
- **Check Valves-** Each Edson unit is equipped with two clear 2" check valves. (Some Applications require BRONZE CHECK VALVES). The check valves are designed to operate automatically, opening and closing when the unit switches from vacuum to pressure mode. In the vacuum mode, the check valve mounted near the top to the tank should be open. If the unit is not pumping properly or pumping is taking longer than normal, the intake and outlet check valve should be checked to see if any debris is keeping it from opening completely. If a check valve is clogged, it may be removed for cleaning or you can try the following:
 1. Close the discharge check valve.
 2. Start the pump in the vacuum mode.
 3. Suck clean water into the tank flushing the inlet check valve.
 4. When the tank is full close the inlet ball valve and let pressure build in the tank.
 5. Open the discharge ball valve to flush the discharge check valve.
- **Moisture Traps-** The Edson unit is equipped with a primary ball and cage shutoff which is built into the tank. This primary shutoff will shut off the vacuum line to the pump in the event the level control probe fails. A secondary clear bowl moisture trap is installed on the tank to pump line in case any moisture or waste gets past the primary shutoff. This clear bowl trap should be checked periodically for moisture and drained accordingly.
- Rewind hose.

2. As required:

- Check oil level. Refill when low. Use biodegradable hydraulic oil or 10W-30 or 10W-40 oil.
- Drain and clean secondary trap.
- Do pressure test. Page 12

3. Every 500 hr:

- **Clean Regulators:** Take each regulator apart and wipe clean. Reassemble and adjust per instructions. Page 13
- **Air Filter-** Replace as required. Order# 161-A-1629-A The air filter is found inside the canister. It is a cartridge filter that removes particles from ambient air when the vacumaster is in the pressure mode.
- **Flush Air Pump -** Flush the system at least once a year (twice a year if used regularly) or if the pump gets a significant amount of water sucked into it.

Air Pump Flushing

Performed for regular maintenance, in cases of water being sucked into the pump (*See Trouble Shooting / Condition*) sucked into the pump or vacuum pump does not turn freely by hand.

1. Unscrew Vacuum Regulator.
2. Pour about 1/2 cup of kerosene into the tee opening. It will drain down into the pump.
3. Press the Pressure Button for the count of 5 and then press the Stop Button.
4. Let the pump sit for 10 min. and then run in the pressure mode for about 15 seconds. If pump will not run let the kerosene sit for two hours. Try and turn the pump by hand. If it still will not turn, wait one day. If after one day the pump will not turn over, the pump must be disassembled and cleaned.
5. If the pump runs, make sure the oil reservoir is full and run the pump so oil enters the pump unit.

Air Pump Maintenances & Rebuilding

The main replaceable parts are vanes (four per pump), bearings (two per pump) and seals (two per pump)

See for Conde "Operating Instructions" for detailed instructions on rebuilding the Conde pump. Service kits are available for mechanically inclined owners and operators. We also offers a factory exchange program and a factory repair program.

Condition 1. No Vacuum At Of Suction Line**Isolating The Problem:****Step 1 - Check motor. Push green start button on pump unit.**

1. Motor is not running. See Electrical & Trace Problem.
2. Motor is running. Proceed to Step 2

Step 2 - Check for tank pressure. Close inlet and discharge ball valves on the tank.

1. Vacuum gauge still reads 0. See Condition 2.
2. Vacuum gauge builds vacuum to regulator preset. Proceed to Step 3

Step 3 - Isolate pressure leak. Close tank ball valves with unit running in vacuum and open discharge ball valve.

1. Vacuum gauge drops. See Check Valves, Pg. 17.
2. Vacuum gauge holds vacuum to regulator preset. Proceed to Step 4

Step 4 - Isolate pressure leak. Close tank ball valves with unit running in vacuum and open suction ball valve.

1. Vacuum gauge drops. Check for break in suction line. Check Suction Plumbing
2. Vacuum gauge holds vacuum to regulator preset but no vacuum. Check for blockage in suction line

Condition 2. Air pump is running but vacuum/ pressure guage reads 0 or very low with inlet and discharge ball valves closed. Problem is isolated to vacuum pump unit. Remove cover and track pump unit operation in the following sequence: (Keep Ball Valves Closed)

1. Check air pump. Run pump unit in pressure mode and check for vacuum at air filter inlet. If no vacuum at air filter, remove filter cartridge and flush air pump. See pg.17. If ok.....
2. Check for air leaks in air pump assembly plumbing. If found tighten or replace fitting or hose. If ok.....
3. Check regulators. See Pg.14. If ok.....
4. Check 4 way electric valve. Remove exhaust and tank hose from out put side of valve. Run unit in vacuum and pressure mode. Is valve switching positions? Is pressure and vacuum strong. If no, call Edson for replacement. If ok.....
5. Check primary trap - ball may be stuck in valve seat. If ok call Edson Customer Service

Condition 3. The Secondary Trap Is Filled With Water.

This usually means that the float switch or the 4 way electrical valve failed to switch the air pump from vacuum to pressure. The primary trap failed to prevent water from being sucked into the secondary trap and possibly the air pump and 4 way valve.

1. Unscrew and empty secondary trap bowl. Put it back and run pump in pressure mode to clear pump and air line of any water. Empty secondary trap bowl again if necessary.
2. Flush air pump See pg.18
3. Turn pump unit off with key switch. Remaining repairs should be done by a licenced electrician familiar with float switch operation. Contact Edson Customer Service for Instructions