



DIAPHRAGM PUMP OUT SYSTEM 284EB

Installation and Operations Manual

Index

- Components pg. 2
- Installation:
 - Pump pg. 3
 - Plumbing pg. 5
 - Electrical pg. 8
- Operation pg. 9
- Parts pg. 12
- Maintenance pg. 16
- Trouble Shooting pg.18

The Pump Out System

A Model 284EB is built with different options that effect installation, performance and service.

- Make sure all the components listed on the packing slip are present
- Make sure the parts list attached to this manual includes all options listed.
- Fill in the important pump information below

Turn to Page 2, Description & Dimensions, for details on components.



ENTER YOUR SYSTEM DATA HERE

SYSTEM SERIAL #

From Edson Serial # Sticker On Pump Frame

PUMP MODEL #

From Plate On The Pump i.e.. GZ 40

PUMP DRIVES: Motor

Reducer

From Plates On Motor and Reducer. i.e. 2hp/1ph/120/230V/TEFC



Description & Dimensions

Pump: 3/4hp/1ph/110-220v/60hz/tefc motor and a 31 to 1 ratio gear reducer coupled to a 40 gpm diaphragm pump. All arranged on a painted aluminum frame with 4 mounting flanges. A contact/timer control box is included. fig. 1

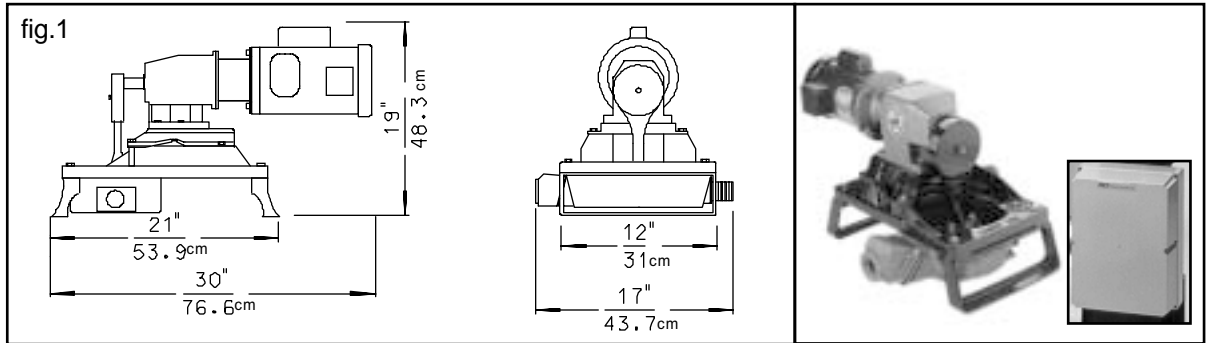

Pump Cover: White Fiberglass with Handles and Pump Out Sign

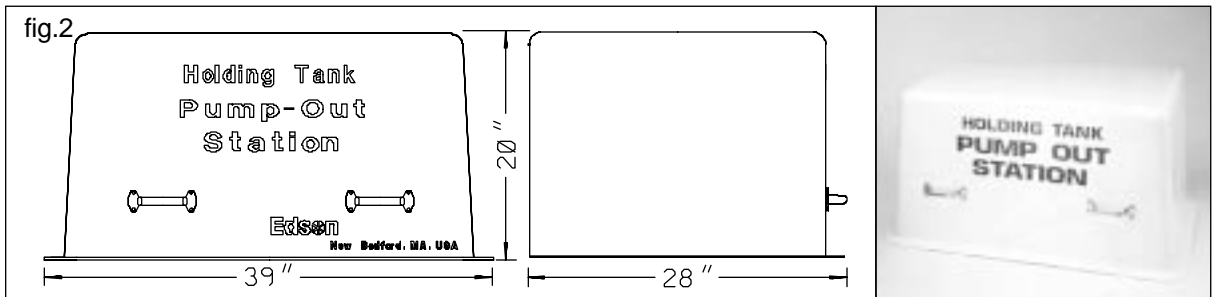

Hose Stand: White Powder Coated Aluminum with Start/Stop Buttons Installed, Operation Instructions and (4) 1/2" X 7" Aluminum Hex Head Mounting Bolts. figs. 3

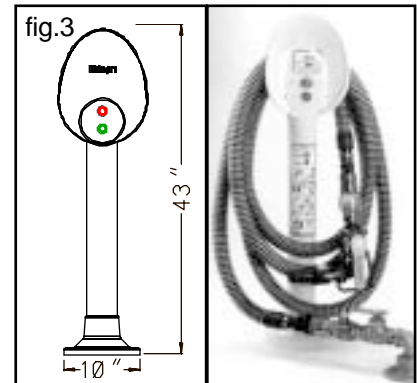

Hose Assembly: 25' X 1 1/2" Polyflex Hose, 90° Ball Valve, Sight Glass/Check Valve, Quick Clamp Adapter, Complete Set of Deck Adapters. fig. 4

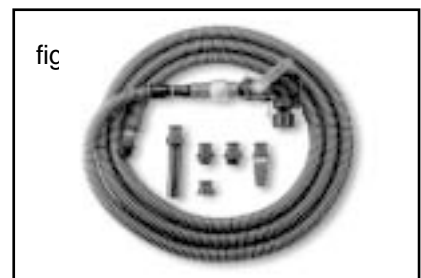

Hydrant (Optional): 1 1/2" Bronze Check Valve, Plated Ball Valve and Quick Clamp Hose Adapter with Bronze Elbow and Close Nipple with Bronze Mounting Flange. figs. 5

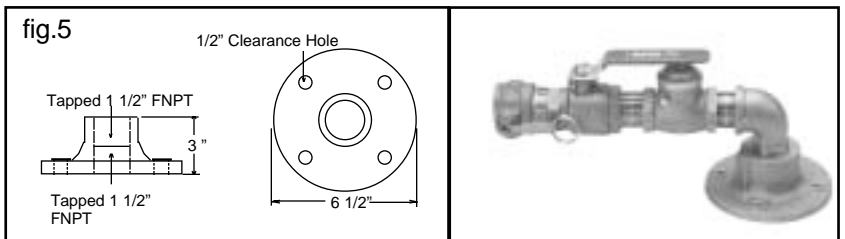

WARNING

Factory Installed Motors Do Not Come Wired.

It is the responsibility of the purchaser to have the electrical service installed by a licensed electrician in accordance with the power requirements of the motor, the electrical service available and local electrical codes.

Failure to have the electricity installed correctly will result in damage to the pump and potential bodily injury, loss of life and property damage from electrical shock and fire.

The Pump:

First Things First.

- Check All Bolts - Make sure that all bolts on the pump are tight. Tools: 2ea. 9/16", 1/2" and 7/16" Box Wrenches. See Fig.8
- Install in accordance with performance specifications and plumbing guidelines. See page 4 & 5
- Check Eccentric for Grease - See instruction labels on pump. See Fig. 8 & Eccentric pg.9
- Plumbing Fittings - Use only large radius elbows and remember No aluminum fittings on a bronze pump and No bronze fittings on an aluminum pump. See Fig. 9
- Install for Maintenance - Install the pump in a manner that allows easy access for inspection & maintenance. Connect plumbing to the pump using unions or easily removed couplings.
- Keep The Pump Horizontal - The pump is designed to be installed on a relatively horizontal surface. If the mounting surface is not horizontal, the discharge should always be higher than the inlet. If not installed accordingly the check valves will not work. The pump base can be rotated 180°. See Fig 10

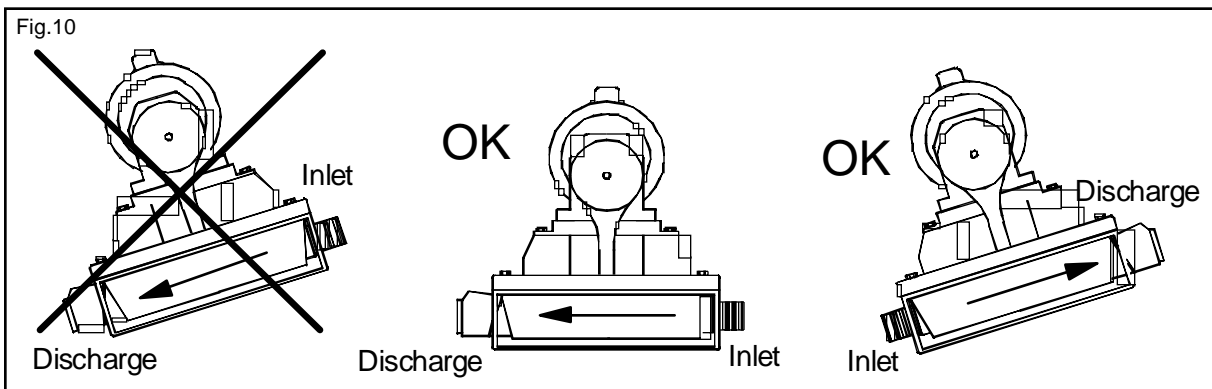
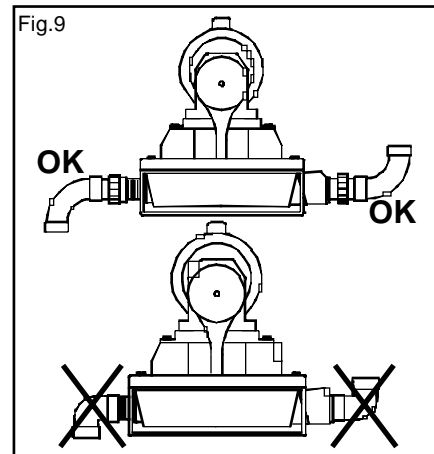
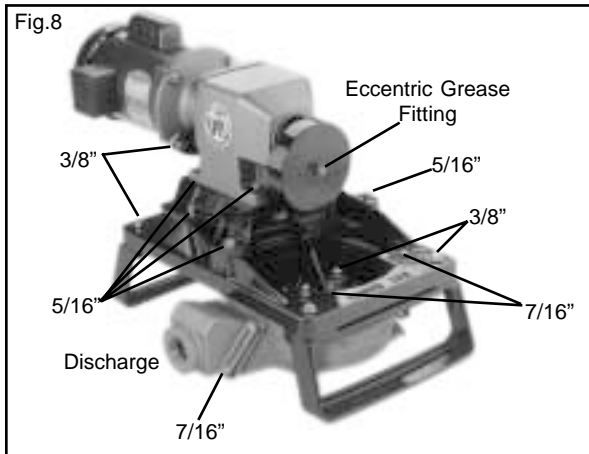

Pump Performance Is Dependent On Cycle Rate & Installation Head:

- Volume is expressed in GPM (gallons per minute) and LPM (liters per minute)
- Cycle Rate is the rpm of the motor divided by the ratio of the reducer. i.e. 1725 rpm / 31= 56
- Head conditions are determined by the height, length and size of the installation plumbing to and from the pump and the viscosity of the liquid.

General Specifications:

- Static Head: Suction 15 ft / 4.57m Discharge 15 ft / 4.57m (2" Hose or Pipe)
- Dry Suction Head: 12 ft / 3.65m (2"ID Pipe or Hose)
- Continuous Duty Discharge Heads: Should be Limited to 10 ft. / 3m
- Performance: 38 GPM / 144 LPM at 4 ft Suction Lift and 0 Discharge at 56 Cycles per Min. w/ 2" Pipe

Volume Charts:

- Use these as a guide to determine the performance to expect from the pump you are installing. Volumes are based on the suction height, discharge height and speed while pumping water through 2" pipe. Actual performance will vary based on length of the plumbing and the viscosity of the liquid being pumped.

56 Cycles Per Min.		DISCHARGE HEIGHT		
		0	5 ft 1.5 m	10 ft 3 m
S U C T I O N H E I G H T	1 ft .3 m	38/144	32/121	24/91
	5 ft 1.5 m	30/114	30/114	23/87
	10 ft 3 m	28/106	26/98	16/61
	12 ft 3.7 m	28/106	26/98	14/53

gpm / lpm

40 Cycles Per Min.		DISCHARGE HEIGHT		
		0	5 ft 1.5 m	10 ft 3 m
S U C T I O N H E I G H T	1 ft .3 m	27/102	23/87	17/64
	5 ft 1.5 m	21/81	21/81	16/62
	10 ft 3 m	20/76	19/70	11/43
	12 ft 3.7 m	20/78	19/70	10/38

gpm / lpm

36 Cycles Per Min.		DISCHARGE HEIGHT		
		0	5 ft 1.5 m	10 ft 3 m
S U C T I O N H E I G H T	1 ft .3 m	24/92	21/78	15/58
	5 ft 1.5 m	19/73	19/73	15/56
	10 ft 3 m	18/68	17/63	10/39
	12 ft 3.7 m	18/68	17/63	8/30

30 Cycles Per Min.		DISCHARGE HEIGHT		
		0	5 ft 1.5 m	10 ft 3 m
S U C T I O N H E I G H T	1 ft .3 m	20/77	19/72	17/64
	5 ft 1.5 m	17.5/66	17/64	16/61
	10 ft 3 m	17/64	16/61	15/57
	12 ft 3.7 m	13/49	12/47	10/38

gpm / lpm

20 Cycles Per Min.		DISCHARGE HEIGHT		
		0	5 ft 1.5 m	10 ft 3 m
S U C T I O N H E I G H T	1 ft .3 m	14/52	11/42	9/34
	5 ft 1.5 m	11/42	11/42	8/31
	10 ft 3 m	10/38	9/34	6/22
	12 ft 3.7 m	10/38	9/34	5/19

gpm / lpm

13 Cycles Per Min.		DISCHARGE HEIGHT		
		0	5 ft 1.5 m	10 ft 3 m
S U C T I O N H E I G H T	1 ft .3 m	9/34	7/26	5/20
	5 ft 1.5 m	7/26	7/26	5/20
	10 ft 3 m	7/26	6/23	4/14
	12 ft 3.7 m	7/26	6/23	3/12

- **DO NOT SHUT OFF DISCHARGE WHEN THE PUMP IS RUNNING.** See Fig 11 - Do not place the pump in a situation where the discharge line will be closed while the pump is running. BECAUSE the Edson pump is a positive displacement pump and it will continue to try to pump liquid through a closed line. The pressure created will cause damage to the pump.
- **DISCHARGE FITTINGS, PIPE AND HOSE SHOULD ALL BE THE SAME SIZE AND NEVER BE SMALLER THAN THE INLET.** See Fig. 12 BECAUSE a smaller discharge line increases work for the pump and increases the possibility of clogging.
- **DO NOT INSTALL THE PUMP AND PLUMBING SO AIR WILL BE TRAPPED.** See Fig. 13 BECAUSE trapped air can completely restrict the flow or at the least require more work from the pump resulting in early diaphragm failure. Install pump and plumbing so any air introduced into the plumbing will not be trapped but flow naturally through liquid and out of the system.
- **SHOULD NOT INSTALL PUMP WITH POSITIVE HEAD ON THE INLET** See Fig. 14 - Under standard operating guidelines the pump should be above the liquid it is being used to transfer. BECAUSE of the flow through check valves, stopping the pump will not stop the liquid from flowing. Under the force of gravity liquid will pass right through a diaphragm pump. Also consider a diaphragm pump can not control a siphon condition. They are used many times to start one.

Use Only Non Collapsing Hose and Pipe On the Inlet and Discharge of the Pump

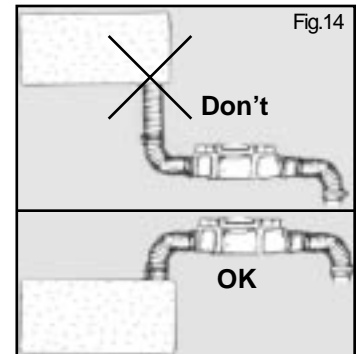
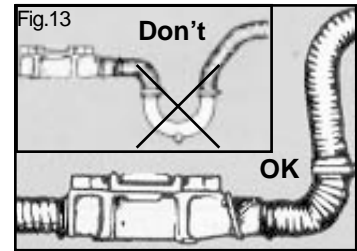
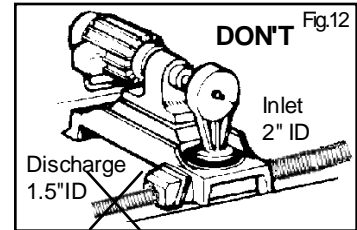
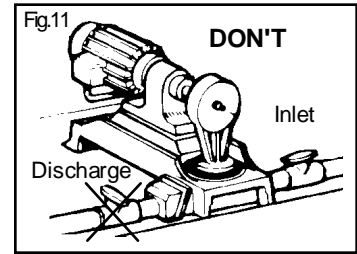

Running The Pump Dry:

The Bone Dry Pump will run dry indefinitely without damage.

Self Priming:

The Bone Dry Pump will develop a dry start vacuum of 10 to 12 inches of mercury, equal to a height of approximately 12'. After the pump is primed the vacuum pressure will increase to 15" hg or more. The self priming feature depends on:

- An air tight suction line.
- The flapper check valves sealing properly. Solids trapped under the check valves will prevent self priming. This is likely to occur when the pump is used in sewage or sump pump out applications. Flushing with water will generally clear out the solid matter. Installing secondary clear flapper check valves right at the inlet and discharge will improve the dry suction start performance of the pump and make clearing the valves easy. Order Edson Clear Check Valves 269CL-200 (2") or 269CL-150 (1.5"). See Fig.15
- USING A DISCHARGE LOOP - For sewage and sump applications when the discharge line drains down and away from the pump, installing an 8" to 10" positive loop right on the discharge port will improve the self priming feature. When you stop pumping the loop traps some liquid against the discharge valve improving the seal. See Fig.16

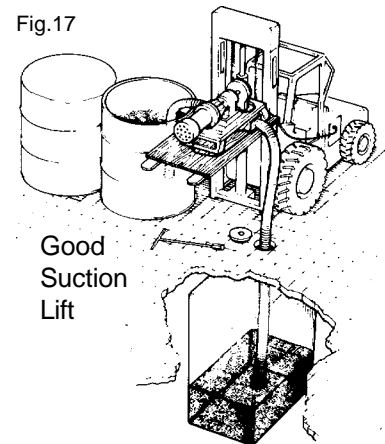
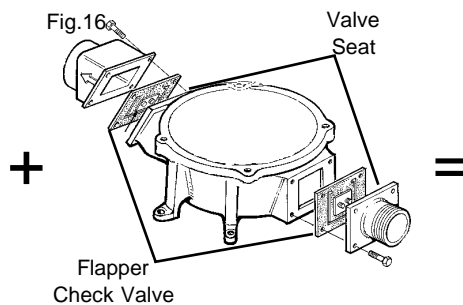
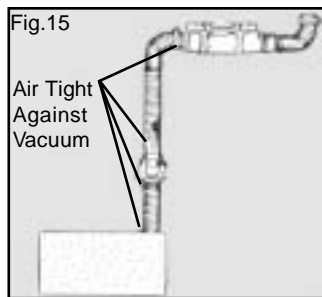
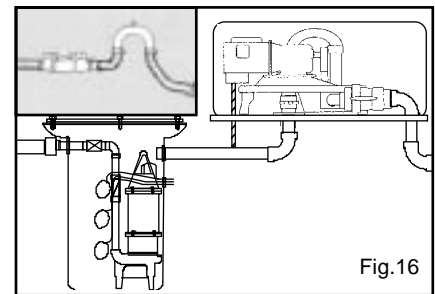
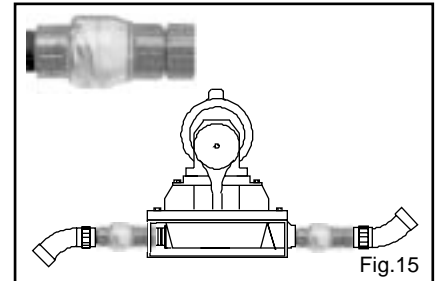

The Hose Stand & Hydrant:

1. Inspect the Hose Stand

- Check the hose stand and 4 mounting bolts. Make sure stop/start switches are installed and are secure. fig.18

2. Assemble The Hydrant per fig 19

- Use thread sealant on all components to insure all fittings are air tight.

Important

Plan for the electrical cable to be installed to the switches through the bottom of the hose stand and the 1 1/2" suction line to the bottom of the hydrant

3. Arrange the Stand and Hydrant at Pump Out Location:

- Position the hose stand and the hydrant so the hose can be easily wound and unwound from the stand. fig 19
- Position the hose stand and hydrant so that the 25 ft. hose can easily reach the boats to be pumped.
- Support hydrant with a plumbing hanger if necessary.
- Use the aluminum mounting bolts to secure the hose stand to the surface. If the 7" mounting bolts supplied can not be used, use appropriate substitutes. Aluminum is recommended. fig. 18
- Secure hydrant to surface with appropriate hardware.

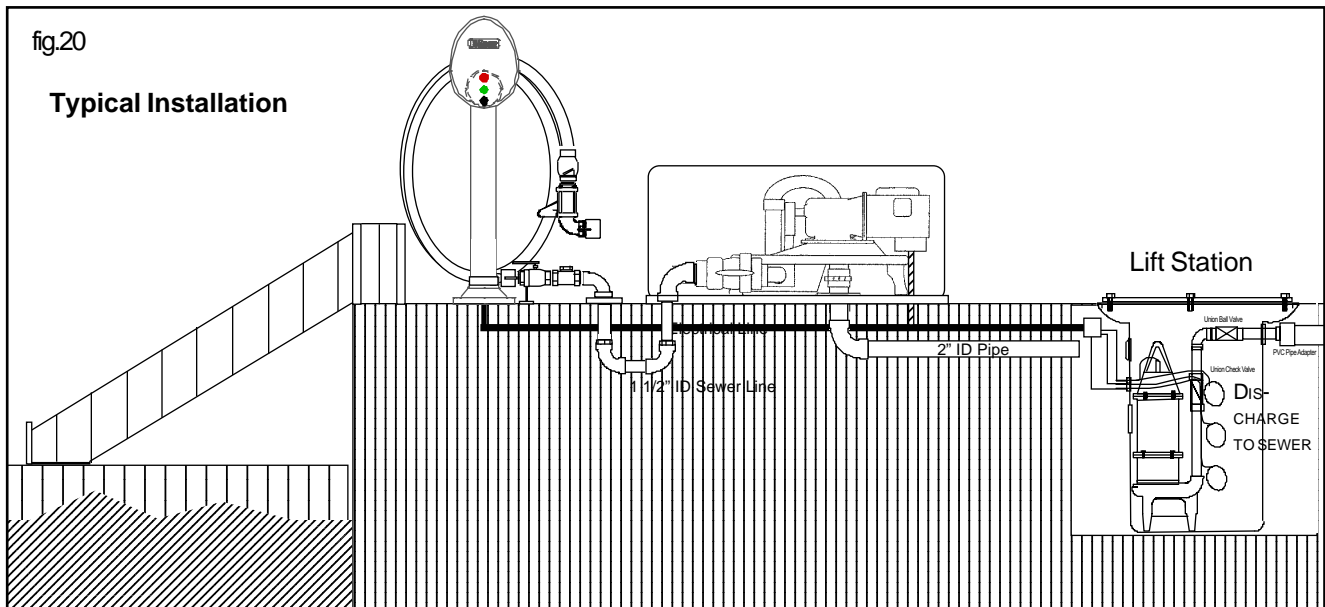
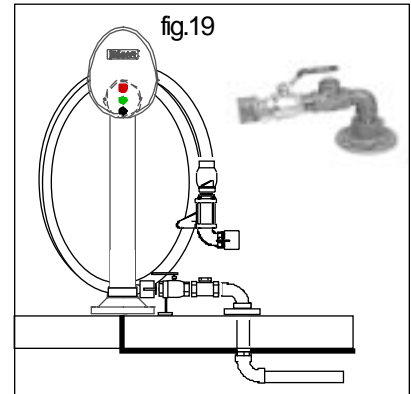
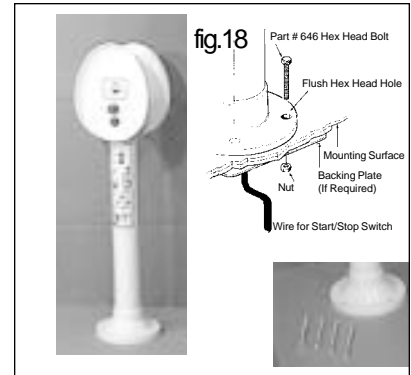

Caution
All Electrical Connections Must Be Installed By a Licensed Electrician In Accordance With Local Codes

Contact Timer Can Be Wired for 120 Volt Or 240 Volt Follow Instructions On Wiring Diagram Page 9 Copy Also Enclosed Inside Control Box

1. Wire The Pump Out Station:

- Use the wiring diagram, page 9 and the following guidelines.
- Open the Contact /Timer Control Box. fig.21

Important
Transformer Jumper/Jumpers Must Be Installed For Either 120 Volt or 240 Volt

- Install the appropriate terminal jumper/jumpers on the transformer per the wiring diagram (TRANSFORMER CONNECTIONS) page 9. Two contact jumpers are provided in a small package inside the control box.

Important
2 hp Motors Operating On 120 Volt Are Rated At Full Load AMPS of 23 & 12 AMPS for 240 Volt

- Wire motor per voltage diagram on motor legend plate. fig. 21. Pay attention to motor rotation.
- Wire motor to contact block per wiring diagram.

Important
Requires (4) Wire To Connect Start Stop Switches to Contact/Timer Control Box

- Wire start & stop switch on hose stand to terminal strip in contact control blocks. Wire a ground from hose stand to control box mounting plate. fig. 22
 Wire multiple start stop stations to the contact timer according to fig.23
- Set the timer. fig. 24

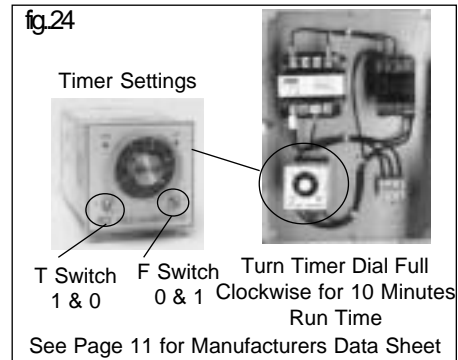
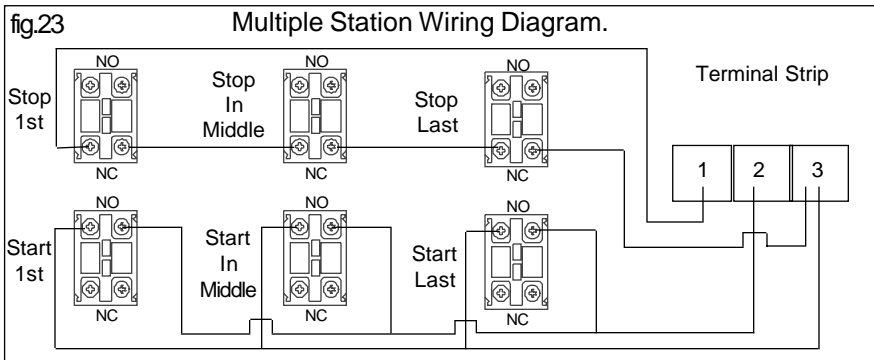
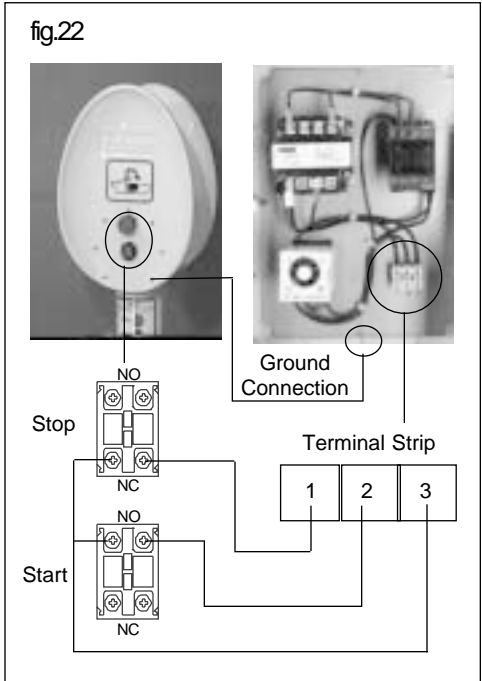
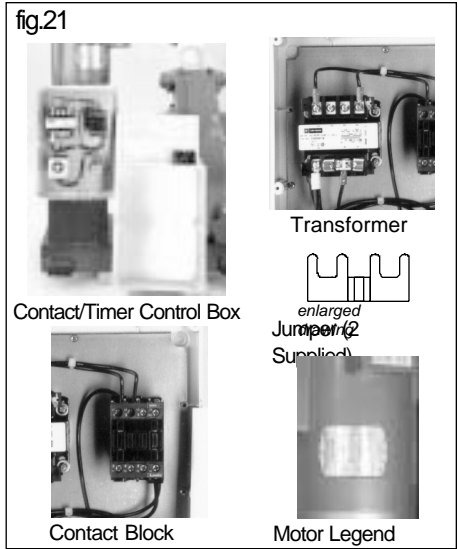

Install the Pump Out Hose Assembly

1. Assemble and Install the Pump Out Hose

- **Use Pipe Sealant On All Threads When Assembling Hose Components.**
- Part 158MF-150NY is an optional fitting used to adapt the thread on the hose end to quick clamp.
- 274-150 is a nozzle extension for use when pumping out portable toilets
- 273-150 & 125 are waste deck fitting adapters. They are screwed into a boat waste deck fitting so the hose can be clamped in place.
- 272QC-150 is a nozzle for use when either of the waste deck fitting adapter do not fit into the boat fitting. It is clamped onto the suction end of the hose and then held into the boat waste deck fitting.

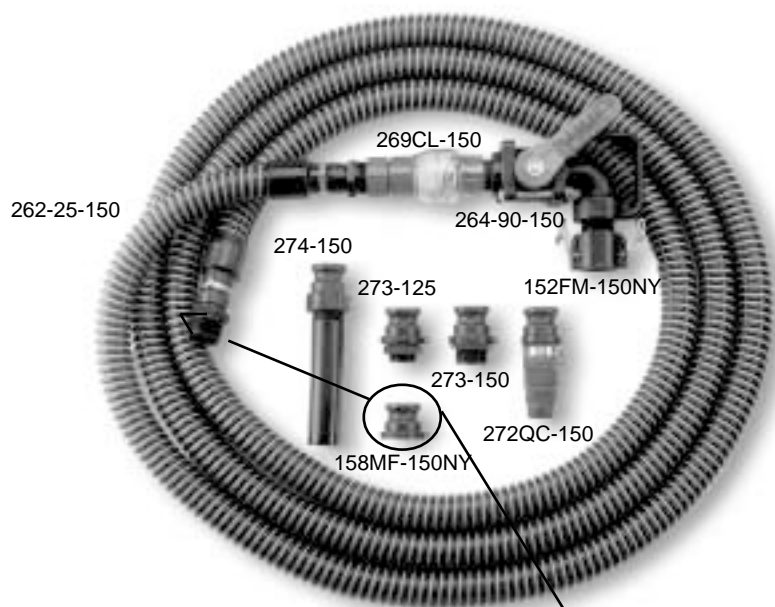

2. Parts List

152FM-150NY Quick Clamp Adapter 1 1/2" QC Fe X Ma Npt
 158MF-150NY Quick Clamp Adapter 1 1/2" QC Ma X Fe Npt
 262-25-150 Hose Assembly
 264-90-150 90° Ball Valve
 269CL-150 Check Valve
 272QC-150 Pump Out Nozzle
 273-125 Deck Adapter 1 1/4"
 273-150 Deck Adapter 1 1/2"
 274-150 Potty Wand

Operation

Pumping Out

1. Make Sure Hydrant Ball Valve Is Open & Hose 90° Ball Valve is Closed.

2. Prepare The Waste Deck Fitting On the Boat.

- Remove the cap from the deck fitting.
- Screw in a deck adapter, 1 1/2" or 1 1/4".
- If neither fit, clamp the universal nozzle to the hose.
- If pumping out a portable holding tank or bucket, clamp the potty wand to the hose.

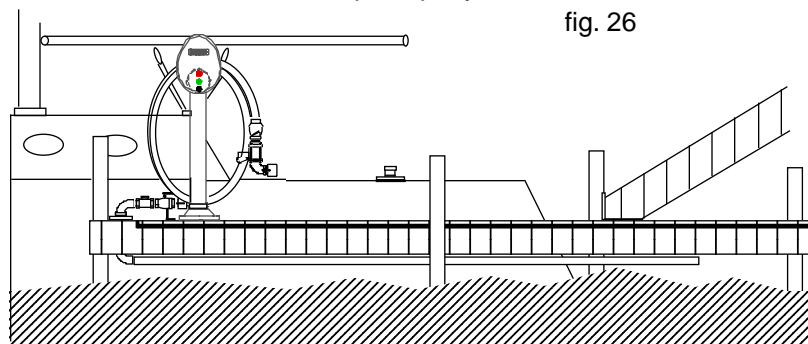

3. Turn On The Pump Out System.

- Push the green start button

4. Connecting The Hose To The Boat

- Unwind the hose all the way from the hose stand.
- Clamp the hose to the deck adapter or hold the universal nozzle in the deck fitting.

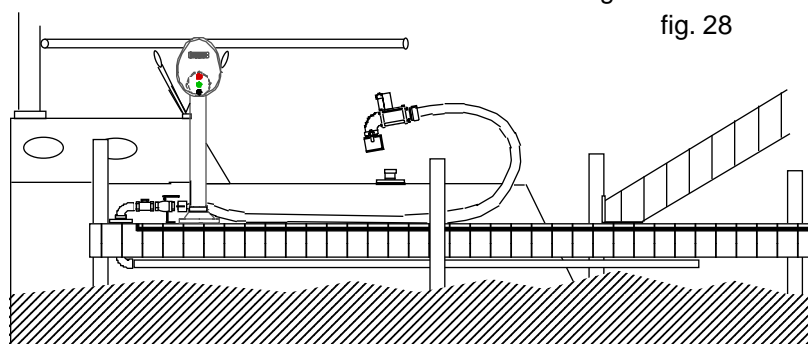
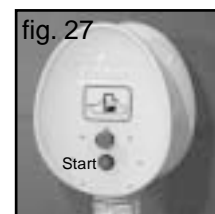

5. Open The Ball Valve Slowly & Pump Out.

- When the holding tank is empty, close the ball valve.
- Pump water through your toilet into the holding tank.
- Pump out again. This procedure rinses the entire system and helps to prevent odor.
- Close The Ball Valve & Disconnect The Hose

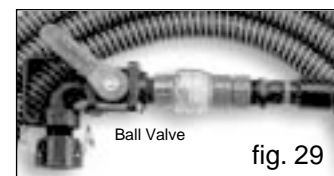

6. Flush the Hose.

- Put the hose into water & open the ball valve for 10 sec.
- Lift the hose and close the ball valve.
- Push the Red Stop Button.

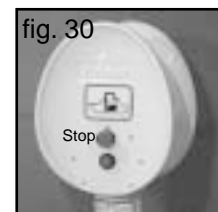

7. Clean Up.

- Curl the hose onto the hose stand.
- Secure the boat deck fitting.
- Rinse the deck and pump out with water.
- Wash your hands.

Parts

Enclosure

- 1 B-601 White Fiberglass Enclosure
- 2 A-1663 Handle (2)
- 3 A-1421-3 Holding Tank Pump Out Sign

Hose Stand 260-284

- 4 646-7hex Hex Head Aluminum Bolts
- 5 A-1705 Momentary Mushroom Switch Red
- 6 A-1704 Momentary Switch Green
- 7 A-1693-2 Pump-Out Instruction Sign
- 8 A-1693-3 Pump-Out Logo Sign



Bronze Hydrant 270BR-150 (Optional)

- 9 152MF-150BR Adapter, Quick Clamp Female QC X MNPT 1 1/2" Bronze
- 10 269BR-150 Valve, Swing Check Bronze
- 11 264-150BR Valve, Ball Full Port 1 1/2" Bronze
- 12 160-A-1711 Elbow, 90 Street 1 1/2" Bronze
- 13 160-A-1708 Nipple, Close 1 1/2" Brass (Qty 2)
- 14 160-B-468 Flange, Size 0 Bronze Tapped 1 1/2" FNPT Both Ends

Enclosure

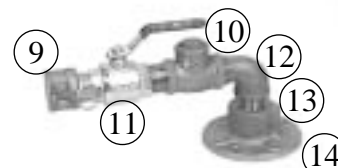
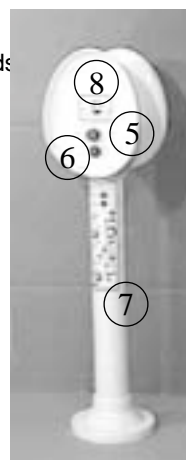

Bronze Hydrant 270BR-150

Hose Assembly 261-25-150

- 15 262-25-150 Hose
- 16 269CL-150 Clear Swing Check Valve
- 17 264-90-150 90 Degree Ball Valve 1.5"
- 18 152FM-150NY Quick Clamp Adapter 1 1/2" FQC X MNPT
- 19 158MF-150NY Quick Clamp Adapter 1 1/2" MQC X FNPT
- 20 273-150 1 1/2" Deck Adapter
- 21 273-125 1 1/4" Deck Adapter
- 22 272QC-150 QC Pump Out Nozzle
- 23 274-150 Potty Wand

Hose Stand 260-284

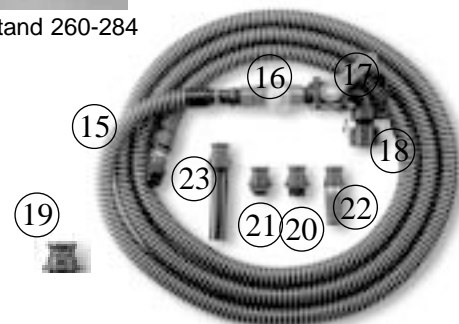

Hose Assembly 261-25-150
Pump Out Adapters

Pump Assembly

- 24 A-2000 2 HP Contact Timer w/ 24 Volt Transformer
- 25 120ELB-40-200 Edson Bone Dry Pump Parts Drawing Page 10

Pump Assembly

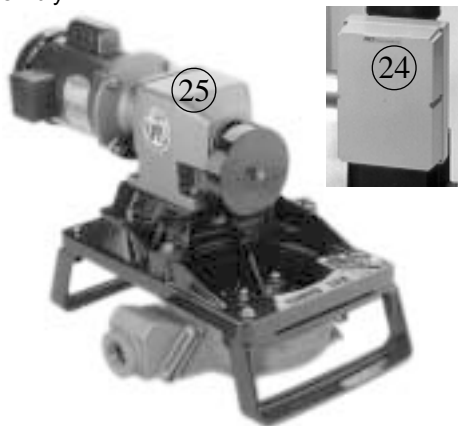

120ELB-40-200 Parts Drawing

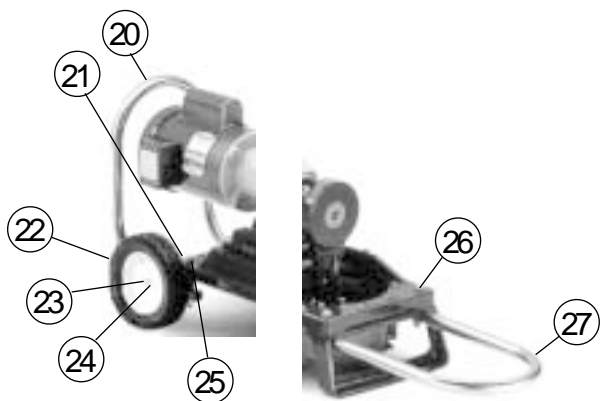
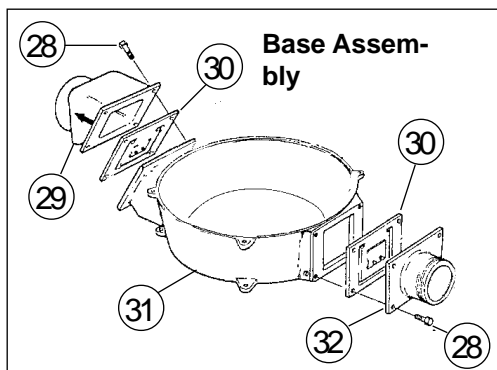
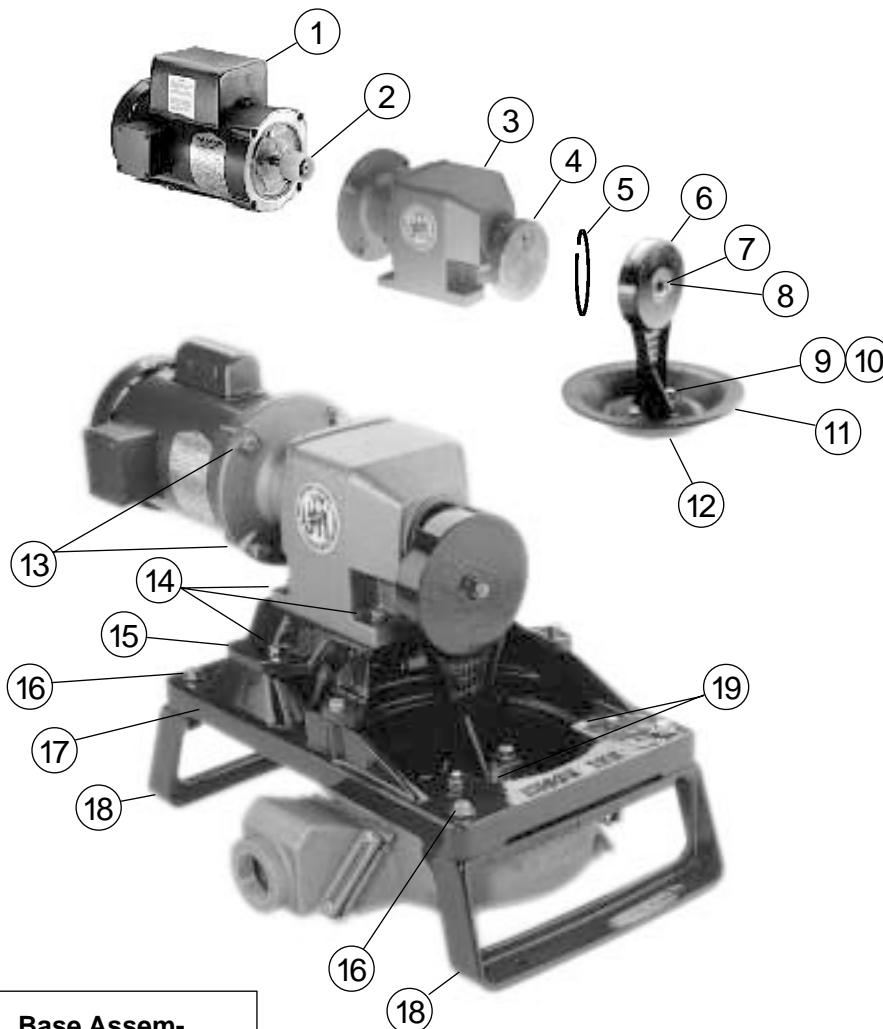
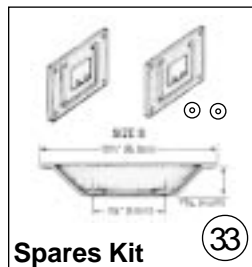

Parts List 120ELB-40-200

P-99-284EB pg. 14

Edson Order #	Description
120ELB-40-200	Bone Dry Electric Diaphragm Pump, Skid Mounted, Bronze, 2" MNPT Inlet and 2" FNPT Discharge

Key #	Edson Order #	Description (nsn number if there is one)	Qty
1	161-A-161	3/4 HP, 1725 RPM, 120/240V, 60HZ, TEFC, Electric Motor (6105013331595)(This is the standard motor. An optional motor may have been installed on the pump. Check legend plate on the motor.)	1
2	161-A-1811-2	Motor Coupling for A-1743 Reducer (included with Reducer key #3)	1
3	161-A-1743	31 to 1 C-Face Gear reducer and coupling (includes Motor Coupling & Eccentric Disk key #s 2 & 4)	1
4	161-A-168	Eccentric Disk (included with Reducer key # 3)	1
5	161-A-1161	Snap Ring (included with Eccentric Housing key #6)	1
6	161-A-1213	Eccentric Housing With Snap Ring (includes Zerk Fitting & Snap Ring key #s 6, 7, 8)	1
7	161-A-150	Zerk Grease Fitting (included with Eccentric Housing key #6)	1
8	161-A-399	Zerk Fitting Dust Cap (included with Eccentric Housing key #6)	1
9	3/8-16X1.25" HHCS	Stainless Hex Head Cap Screws	2
10	160-A-1200	Sealing Washers (5310013938514) Not Shown	2
11	113H-0	Diaphragm (4820013935286)	1
12	160-A-906	Lower Standard (4320013331830)	1
13	3/8"-16X1" HHCS	Stainless Hex Head Cap Screws	8
14	5/16"-18X1.25"HHCS	Stainless Hex Head Cap Screws	4
15	161-C-583	Reducer Mounting Adapter Plate	1
16	3/8"-16X2.5" HHCS	Stainless Hex Head Cap Screws	4
17	161-D-69	Pump Frame	1
18	161-C-389	Pump Leg	2
19	1/4"-20X1.5 HHCS	Stainless Hex Head Cap Screws with Washers	4
20	161-A-1299	Motor Guard (Optional part installed only when ordered)	0
21	161-A-164	Axle Hanger	0
22	161-A-166	Wheel	0
23	161-A-143	Pal Nut	0
24	161-A-165	Stainless Axle	0
25	3/8"-16X4" HHCS	Stainless Hex Head Cap Screws with Nuts and Washers	0
26	3/8"-16X3" HHCS	Stainless Hex Head Cap Screws with Nuts and Washers	0
27	161-A-147	Pump Handle	0
28	1/4"-20X1 HHCS	Stainless Hex Head Cap Screws with Nuts and Washers	8
29	160-B-50B-200	Bronze Discharge Chamber 2"	1
30	160-G-107	Inlet/Discharge Valve Assembly (4320013235967)	2
31	160-C-298	Bronze Side Inlet Pump Base	1
32	160-B-68B	Bronze Suction Chamber 2"	1
33	114H-117-120	Bone Dry Spares Kit (4320013433658) Includes: Qty 1 - 113H-0 DIAPHRAGM (key # 3) Qty 2 - 160-G-107 (key #27) Qty 2 - 160-A-1200 (key # 32)	



85 SERIES TIMER • MULTI FUNCTION/RANGE/VOLTAGE

ADVANCE CONTROLS' 85 SERIES MULTI FUNCTION/RANGE VOLTAGE TIMERS OFFER A CHOICE OF FOUR (4) TIMING FUNCTIONS, FOUR (4) TIMING RANGES, AND A WIDE RANGE OF INPUT VOLTAGES



MULTI FUNCTION: WITH THE PROPER SETTING OF THE "F" (FUNCTION) DIP SWITCH, THIS ACI TIMER CAN FUNCTION EITHER AS AN ON DELAY, REPEAT CYCLE, INTERVAL (REVERSE ON DELAY) OR A REVERSE REPEAT CYCLE TIMER.

MULTI RANGE: WITH THE PROPER SETTING OF THE "T" (TIME) DIP SWITCH, THE ACI TIMER OFFERS A CHOICE OF FOUR (4) TIMING RANGES (0.05 / 1 SEC : 0.12/10 SEC: 0.6 SEC/1 MIN: 6 SEC/10 MIN. OR 0.05/1 MIN: 0.12/10 MIN: 0.6 MIN/1 HOUR: 1 MIN/10 HOUR).

WIDE RANGE INPUT VOLTAGE: A WIDE RANGE OF INPUT VOLTAGES ARE ALLOWED (24 VAC/VDC THROUGH 240 VAC/VDC, 50/60 HZ) WITHOUT WIRING CHANGES OR DIP SWITCH SETTINGS.

THE FEATURES OF THE ADVANCE CONTROLS TIMER MINIMIZE INVENTORY WHILE MAXIMIZING THE BENEFITS FOR TIMER APPLICATIONS.



CATALOG NUMBERS / TIME RANGES

CATALOG NUMBER	MODEL NUMBER	OUTPUT	TIMING RANGE	DIP SWITCH "T" (TIME RANGE) SETTING				LIST PRICE
				0 0	1 0	0 1	1 1	
104214	8511A240	11 PIN	SEC [s] - MIN [m]	0.05s - 1s	0.12s -10s	0.6s-1m	6s-10m	\$ 64.00
104216	8521A240	DPDT	MIN [m] - HOUR [h]	0.05m - 1m	0.12m-10m	0.6m-1h	1m-10h	64.00
104217	8542A240	8 PIN	SEC [s] - MIN [m]	0.05s - 1s	0.12s-10s	0.6s-1m	6s-10m	62.00
104218	8552A240	SPDT	MIN [m] - HOUR [h]	0.05m - 1m	0.12m-10m	0.6m-1h	1m-10h	62.00

FUNCTION CHART

FUNCTION	DIP SWITCH "F" (FUNCTION) SETTING	DESCRIPTION
"ON" DELAY	0 0	TIMING BEGINS WHEN POWER IS APPLIED TO THE UNIT. THE OUTPUT CONTACTS TRANSFER WHEN THE TIME DELAY SETTING IS REACHED TO RESET THE TIMER. REMOVE THE INPUT POWER OR OPERATE THE CUSTOMER SUPPLIED EXTERNAL "RESET" SWITCH.
REPEAT CYCLE	1 0	TIMING BEGINS WHEN POWER IS APPLIED TO THE UNIT. THE OUTPUT CONTACTS TRANSFER WHEN THE TIME DELAY SETTING IS REACHED. THE OUTPUT CONTACTS REMAIN TRANSFERRED UNTIL THE TIME DELAY SETTING IS AGAIN REACHED. THE OUTPUT CONTACTS ARE THEN RELEASED AND RETURN TO THE ORIGINAL STATE. THE TIMER THEN AUTOMATICALLY RESETS AND REPEATS THE TIMING CYCLE UNTIL THE INPUT POWER IS REMOVED.
INTERVAL (REVERSE ON DELAY)	0 1	APPLYING POWER TO THE TIMER IMMEDIATELY TRANSFERS THE OUTPUT CONTACTS AND TIMING BEGINS. ONCE THE TIME DELAY SETTING IS REACHED, THE OUTPUT CONTACTS ARE RELEASED. THE TIMER IS RESET EITHER BY REMOVING THE INPUT POWER OR OPERATING THE CUSTOMER SUPPLIED EXTERNAL "RESET" SWITCH.
REVERSE REPEAT CYCLE	1 1	APPLYING POWER TO THE TIMER IMMEDIATELY TRANSFERS THE OUTPUT CONTACTS AND TIMING BEGINS. THE OUTPUT CONTACTS REMAIN TRANSFERRED UNTIL THE TIME DELAY SETTING IS REACHED. THE OUTPUT CONTACTS ARE THEN RELEASED AND WHEN THE DELAY SETTING IS AGAIN REACHED, THE OUTPUT CONTACTS TRANSFER AND REMAIN TRANSFERRED UNTIL THE TIME DELAY SETTING IS AGAIN REACHED. THE TIMER CONTINUES TO AUTOMATICALLY REPEAT THE CYCLE UNTIL THE POWER IS REMOVED.

RESET SWITCH: RESETS THE TIMER TO ZERO. REQUIRES CUSTOMER SUPPLIED MOMENTARY SWITCH.

MEMORY SWITCH: PAUSES THE TIMING CYCLE AT THAT POINT IN THE CYCLE. WHEN RELEASED, IT ALLOWS THE CYCLE TO RESUME FROM THE SAME POINT. REQUIRES A CUSTOMER SUPPLIED MOMENTARY SWITCH.

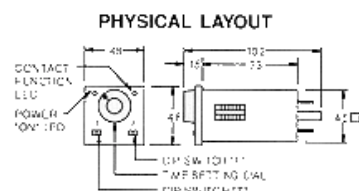

- NOTE:
- SQUARE PANEL MOUNT ADAPTOR (DIN 48 MM) AVAILABLE FOR SNAP MOUNTING INTO A PANEL CUTOUT
 - ALL DIMENSIONS ARE IN MILLIMETERS (INCHES + MM 25.4)

CONNECTION DIAGRAM

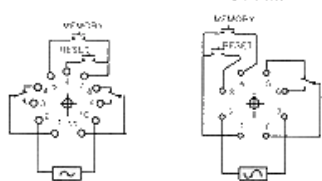

INPUT VOLTAGE: 24 - 240 VAC/VDC 50/60 HZ

SOCKET: ZVR11 OR ZVD11 SOCKET: ZVR8 OR ZVD8

SPECIFICATIONS

INPUT VOLTAGE: 24-240 VAC/VDC 50/60 HZ
 CONTACT RATING: 10A/250 VAC 10A/30 VDC
 MOUNTING: 8 OR 11 PIN OCTAL BASE
 INPUTS: POWER, MEMORY (OPTIONAL), RESET (OPTIONAL)
 ELECTRICAL LIFE: 250,000 CYCLES
 REPEATABILITY: +/- 1%
 SETTING TOLERANCE: +/- 10%
 RESET TIME: 0.1 SEC MAX
 OPERATING TEMP: +15 +120 DEG. F (-10 +50 DEG. C)
 OPERATING HUMIDITY: 85% RH MAX

Warning
Lock Out Electrical Service or Unplug the Pump Electrical Line
Before Performing Any Service.
Failure to Do So Will Result In Bodily Injury

How The Pump Works

- The motor and gear reducer rotate the eccentric disk inside the eccentric housing.
- The eccentric housing raises and lowers the diaphragm.
- Raising the diaphragm creating a vacuum. See Fig.15
- The vacuum pulls the discharge valve assembly closed.
- Atmospheric pressure pushes liquid and/or air up the inlet plumbing to fill the vacuum.
- When the diaphragm is driven down the air and liquid under the diaphragm is compressed closing the inlet check valve and forcing the air and liquid out the discharge. Fig.16
- The closing of the inlet valve assembly also prevents the liquid and air trapped in the inlet line from dropping back down (to atmosphere).

Suction Stroke

Inlet Valve Assembly:
 opens into the pump
 Discharge Valve Assembly:
 closes and seals on the valve
 seat that is part of the pump
 base under the discharge
 chamber.

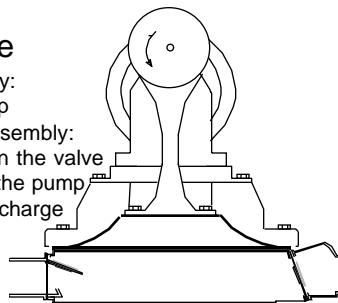

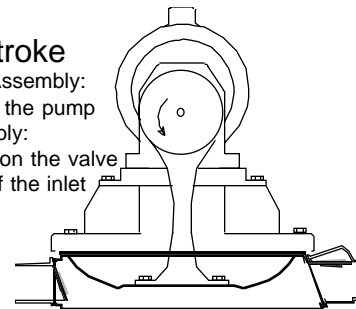

Discharge Stroke

Discharge Valve Assembly:
 opens away from the pump
 Inlet Valve Assembly:
 closes and seals on the valve
 seat that is part of the inlet
 chamber.



Diaphragm: Edson 120 Pumps use Elastomer Diaphragm and Flapper Valves. Over time these parts wear and need to be replacement. The ability to easily and quickly replace these inexpensive parts is one of the major advantages of an Edson diaphragm pumps. Edson has packaged these parts as Spares Kits. See the parts list for the order #s.

- Change the diaphragm as required. See Fig. 31
- Inspection and testing on a regular basis is recommended. For continuous duty application, inspect the pump daily until a life pattern is established.
- Look for leaks, cracks or splits on the surface of the diaphragm.
- Life expectancy is directly related to head conditions, run time and diaphragm material. The higher the suction and discharge pressures the shorter the life.

<p>Step 1. Unbolt Pump Base from Pump Frame with 7/16" wrench.</p>  <p align="center">Fig.31</p>	<p>Step 2. Unbolt the Diaphragm from the Eccentric Housing and Lower Standard (STAINLESS STEEL BACKING PLATE) with 9/16" socket.</p> 	<p>Step 3. Reverse steps 1 & 2 to reassemble pump with new diaphragm and the 2 sealing washers on the 3/8" bolts.</p> <p>Important: Eccentric stays connected to the reducer. Lower Standard must be installed with it's sharp edge away from the bottom of the diaphragm</p> <p>Tools Required: 9/16" Socket Wrench with a 6" Extension (2) 7/16" Box Wrench</p>
--	---	--

Eccentric: A disk called an eccentric is pressed onto the output shaft of the gear reducer. As it rotates inside the bronze eccentric housing the diaphragm is raised and lowered. This assembly needs to be greased with any good gear grease. Edson applies **Mobil Grease HP Multipurpose Premium Grease** during the assembly of the pump. Failure to grease this part will result in early wear.

Valve Assemblies & The Valve Seats: The sealing of the flapper valves are what makes the diaphragm pump work. If the valves are not sealing properly, the pump will not be performing to full potential or may not be pumping at all. The valves tend to last longer than the diaphragm. When you change the diaphragm inspect the valves for cracks and delamination and the valve seats for pitting and any build up that will prevent the valve rubber from sealing effectively. Testing the pump is the best way to evaluate performance.

- Change the valve assemblies as required. See Fig. 32
- Inspection and testing on a regular bases is recommended. For continuous duty application, inspect the pump daily until a life pattern is established.
- See Pump Performance Tests.

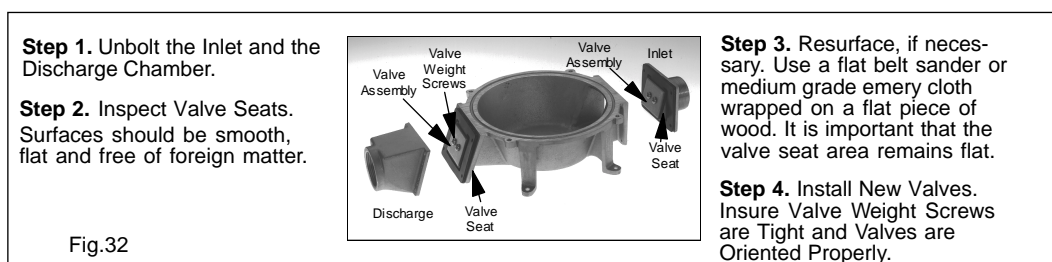

Pump Performance Tests:

- **Vacuum Gauge Test - Tests the performance of the discharge valve and valve seat.**
 1. Attach a 5' length of non-collapsing hose or pipe with a vacuum gauge installed to the inlet of the pump. Make sure the line is completely sealed and air tight.
 2. Turn on the pump and let it run till the gauge stabilizes. Record the reading.
 3. Turn off the pump and watch the gauge.
 4. If the discharge is working properly the gauge should build and hold at 10" to 12"hg. Do not be concerned if the vacuum pressure slowly returns to 0 within a minute or so.
 5. If you do not get any vacuum reading or if the gauge does not get to 10" hg and drops off to 0 as soon as the pump stops, do the same thing again. Listen for air being sucked in around the diaphragm. If you hear air movement, inspect for loose bolts or worn diaphragm. If you hear no air movement, remove the discharge chamber and inspect the valve assembly and valve seat. Clean or replace the valve and clean or resurface the valve seat as appropriate. See Maintenance/Valve Assemblies fig. 32
- **Pressure Gauge Test - Tests the performance of the suction valve and valve seat.**
 1. Attach a 5' length of non-collapsing hose or pipe with a 0 to 15 psi gauge installed to the outlet of the pump. Make sure the line is completely sealed and air tight.
 2. Turn on the pump and let it run till the gauge stabilizes. Record the reading.
 3. If the suction valve is working properly the gage should build and pulse at 6 to 7 psi. and when the pump is stopped the pressure may hold or slowly returns to 0.
 4. If you do not get any pressure reading or if the gauge does not get to 4 psi and drops off to 0 as soon as the pump stops, clean or replace the suction valve and clean or resurface the valve seat as appropriate. See Maintenance/Valve Assemblies fig. 32
- **Manual Test - Testing the pump valves and valve seats without the use of a gauge.**
 1. Remove all fittings from the inlet and discharge of the pump.
 2. Turn on the pump.
 3. Put your hand over the inlet. If the discharge valve is working properly, you should feel a very strong pulsing suction. The pulsing coincides with the raising and lowering of the diaphragm. If you do not feel any suction, do the same thing again and listen for air being sucked in around the diaphragm. If you hear air movement, inspect for loose bolts or worn diaphragm. If you hear no air movement, remove the discharge chamber and inspect the valve assembly and valve seat. Clean or replace the valve and clean or resurface the valve seat as appropriate.
 4. Press your hand over the discharge. If the inlet valve is sealing properly, the pressure of the pump down stroke should push your hand away. If it does not and the air is forced out the inlet remove the inlet chamber and inspect the valve assembly and valve seat. Clean or replace the valve and clean or resurface the valve seat as appropriate. See Maintenance/Valve Assemblies fig. 32

The Edson Electric Powered Diaphragm Pump is very simple and problems are isolated to only the following components:

- **The Motor & Gear Reducer**
- **The Gear Reducer and Eccentric**
- **The Diaphragm and Valves**
- **Suction and Discharge Plumbing**

1.Problem	Possible Causes	Action
Pump is running, liquid is not moving.	<ul style="list-style-type: none"> a. Suction line is blocked. b. Suction line has air leak between liquid and inlet of the pump. c. Discharge and/or suction valves are not working. d. Diaphragm has a leak. e. Discharge or suction line is to high. 	If the cause is not obvious, isolate the source. Disconnect the inlet and discharge plumbing from the pump and perform the Manual Test page 8. If the cause is not in the pump check for a block or an air leak in the suction line. Suction air leaks can be cumulative and can be as simple as one or two fittings not being sealed properly. Review Plumbing
2.Problem	Possible Causes	Action
Motor is starting.	<ul style="list-style-type: none"> a. Electrical Supply or wiring problem. b. Motor worn out. 	Check electrical switch and/or circuit breaker. If not familiar with electrical problems, call an electrician. If circuit breaker is tripped for no apparent reason or the motor is worn out way too soon, check the pump and the line for a blockage or restriction. Review the Performance Specifications and installation Guidelines
3.Problem	Possible Cause	Action
Motor is running but reducer is not moving	<ul style="list-style-type: none"> a. Reducer Coupling has come lose on the motor shaft. 	Remove the motor and reposition and secure the coupling to the motor shaft. See parts diagram for positioning instructions.
4.Problem	Possible Causes	Action
Diaphragm is wearing out much earlier than expected.	<ul style="list-style-type: none"> a. Liquid being pumped is not compatible with the diaphragm material. b. Discharge and/or suction back pressure too high. 	Consult a chemical resistance chart, review the Installation Guidelines . Call Edson Customer Service.
5.Problem	Possible Causes	Action
Pump base and/or lines keep filling with solids	<ul style="list-style-type: none"> a. Line velocity is too slow to keep the solids in suspension. b. The percent of solids is too high. 	Speeding up the pump will help increase the velocity. Using a strainer can reduce the size and percent of solids. Diluting the slurry by increasing the amount of liquid or by increasing the agitation of the mix may solve the problem. Review Pumping Liquids with Suspended Solids