



HYDRAULIC POWERED DIAPHRAGM PUMP MODELS 220H

Installation and Operations Manual

Index:

| | |
|---------|--------------------------|
| Page 1 | The Pump |
| Page 2 | Performance & Dimensions |
| Page 3 | Installation Guidelines |
| Page 5 | Operations |
| Page 7 | Maintenance & Repair |
| Page 9 | Trouble Shooting |
| Page 10 | Parts |

The Pump

A Model 220H is built with different options that effect performance and service.

- Make sure the pump received is the pump ordered. Compare the pump with the packing list.
- Make sure the parts list attached to this manual is the one for your pump.
- Fill in the important pump information below

See Page 6, Pump Construction and Order #, on how to comparing packing list with the pump received.



ENTER YOUR PUMP DATA HERE

PUMP MODEL #
From Packing Slip or Invoice i.e.. 220HLA-150

PUMP SERIAL #
From Edson Serial # Sticker On Pump Frame i.e.. # 25748

PUMP DRIVE: Motor
From Parts List



Performance Specifications

Pump Performance Is Dependent On Cycle Rate & Installation Head:

- Volume is expressed in GPM (gallons per minute) and LPM (liters per minute)
- Cycle Rate is the rpm of the motor. Maximum Cycle Rate - 60 cycles per min.
- Head conditions are determined by the height, length and size of the installation plumbing to and from the pump and the viscosity of the liquid.

General Specifications:

- Static Head: Suction 18 ft / 5.48m Discharge 18 ft / 5.48m (1.5" Hose or Pipe)
- Dry Suction Head: 15 ft / 4.57m (1.5" ID Pipe or Hose)
- Continuous Duty Discharge Heads: Should be Limited to 10 ft. / 3m
- Performance: 18 GPM / 68.4 LPM at 4 ft Suction Lift and 0 Discharge at 56 Cycles per Min. w/ 1.5" Pipe

Volume Charts:

- Use these performance charts as a guide to determine the volume to expect from the pump you are installing. Volumes are based on the suction height, discharge height and speed of the pump pumping water through 1.5" pipe. Actual performance will vary based on length of the plumbing and the viscosity of the liquid being pumped.

| | | DISCHARGE HEIGHT | | |
|-------------------|-----------------------|----------------------|----------------------|----------------------|
| | | 0 | 5 feet 1.5 meters | 10 feet 3 meters |
| SUCTION HEIGHT | 1 foot .3 meters | 18 gpm 68.4 lpm | 17 gpm 64.6 lpm | 17 gpm 64.6 lpm |
| | 5 feet 1.5 meters | 17.5 gpm 66.5 lpm | 17 gpm 64.6 lpm | 15.5 gpm 59 lpm |
| | 10 feet 3 meters | 16.5 gpm 62.7 lpm | 15 gpm 57 lpm | 13.5 gpm 51.3 lpm |
| | 17 feet 4.2 meters | 6 gpm 22.8 lpm | 5 gpm 19 lpm | 4 gpm 15.2 lpm |

| | | DISCHARGE HEIGHT | | |
|-------------------|-----------------------|----------------------|----------------------|---------------------|
| | | 0 | 5 feet 1.5 meters | 10 feet 3 meters |
| SUCTION HEIGHT | 1 foot .3 meters | 12.9 gpm 49 lpm | 12.1 gpm 46 lpm | 12.1 gpm 46 lpm |
| | 5 feet 1.5 meters | 12.5 gpm 47.5 lpm | 12.1 gpm 46 lpm | 11 gpm 41.8 lpm |
| | 10 feet 3 meters | 11.8 gpm 44.8 lpm | 10.7 gpm 40.7 lpm | 9.6 gpm 36.5 lpm |
| | 17 feet 4.2 meters | 5 gpm 19 lpm | 4 gpm 15 lpm | 3 gpm 11.5 lpm |

| | | DISCHARGE HEIGHT | | |
|-------------------|-----------------------|----------------------|----------------------|----------------------|
| | | 0 | 5 feet 1.5 meters | 10 feet 3 meters |
| SUCTION HEIGHT | 1 foot .3 meters | 11.6 gpm 44.1 lpm | 10.9 gpm 41.4 lpm | 10.9 gpm 41.4 lpm |
| | 5 feet 1.5 meters | 11.3 gpm 42.9 lpm | 10.9 gpm 41.4 lpm | 10 gpm 38 lpm |
| | 10 feet 3 meters | 10.6 gpm 40.3 lpm | 9.6 gpm 36.5 lpm | 8.7 gpm 33.1 lpm |
| | 17 feet 4.2 meters | 5 gpm 19 lpm | 4 gpm 15 lpm | 3 gpm 11.5 lpm |

| | | DISCHARGE HEIGHT | | |
|-------------------|-----------------------|-------------------|----------------------|---------------------|
| | | 0 | 5 feet 1.5 meters | 10 feet 3 meters |
| SUCTION HEIGHT | 1 foot .3 meters | 7 gpm 26.5 lpm | 6 gpm 22.8 lpm | 5 gpm 19 lpm |
| | 5 feet 1.5 meters | 6 gpm 22.8 lpm | 5.5 gpm 21 lpm | 5 gpm 19 lpm |
| | 10 feet 3 meters | 5.5 gpm 21 lpm | 5 gpm 19 lpm | 5 gpm 19 lpm |
| | 17 feet 4.2 meters | 5 gpm 19 lpm | 4 gpm 15 lpm | 3 gpm 11.5 lpm |

| | | DISCHARGE HEIGHT | | |
|-------------------|-----------------------|---------------------|----------------------|---------------------|
| | | 0 | 5 feet 1.5 meters | 10 feet 3 meters |
| SUCTION HEIGHT | 1 foot .3 meters | 4.6 gpm 17.5 lpm | 4 gpm 15.2 lpm | 3.3 gpm 12.5 lpm |
| | 5 feet 1.5 meters | 4 gpm 15.2 lpm | 3.6 gpm 13.7 lpm | 3.3 gpm 12.5 lpm |
| | 10 feet 3 meters | 3.6 gpm 13.7 lpm | 3.3 gpm 12.5 lpm | 3.3 gpm 12.5 lpm |
| | 17 feet 4.2 meters | 3.3 gpm 12.5 lpm | 2.7 gpm 10 lpm | 2 gpm 7.6 lpm |

| | | DISCHARGE HEIGHT | | |
|-------------------|-----------------------|--------------------|----------------------|---------------------|
| | | 0 | 5 feet 1.5 meters | 10 feet 3 meters |
| SUCTION HEIGHT | 1 foot .3 meters | 3 gpm 11.4 lpm | 2.6 gpm 10 lpm | 2.2 gpm 8.4 lpm |
| | 5 feet 1.5 meters | 2.6 gpm 10 lpm | 2.4 gpm 9.1 lpm | 2.6 gpm 10 lpm |
| | 10 feet 3 meters | 2.4 gpm 9.1 lpm | 2.6 gpm 10 lpm | 2.6 gpm 10 lpm |
| | 17 feet 4.2 meters | 2.6 gpm 10 lpm | 1.7 gpm 6.5 lpm | 1.3 gpm 4.9 lpm |

Dimensions

220HL Skid Mounted

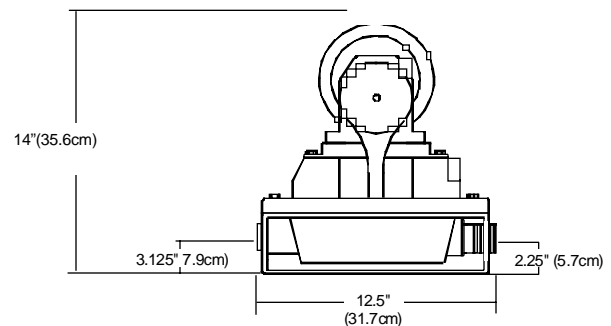
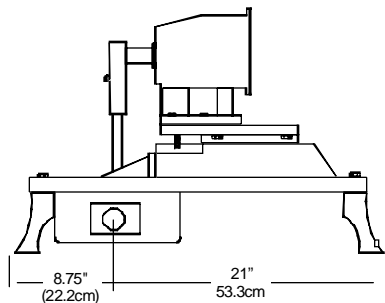

INFORMATION

Hydraulic Motors Do Not Come With Hydraulic Pumps.

It is the responsibility of the purchaser to provide hydraulic power.
 Hydraulic Flow Rate is less than 2 GPM at 1600 PSI for the standard 5.9 in³
 Char-Lynn H-Series Hydraulic Motor.

The ability to control the rpm of the motor between 10 and 60 rpm is a major
 advantage to using this 220H pump.

Maximum rpm is 60. Over 60 rpm tyhe pump starts to cavatate.

First Things First:

- Check All Bolts - Make sure that all bolts on the pump are tight. Tools: 2ea. 9/16", 1/2", 7/16" box wrenches and phillips screw driver. Fig.1
- Install The Handle (Cart Mounted Pumps Only) - Remove spacers & replace with handle.
- Check Eccentric for Grease - See instruction labels on pump. Fig. 1
- Plumbing Fittings - Use only large radius elbows and remember No aluminum fittings on a bronze pump and No bronze fittings on an aluminum pump. Fig. 2
- Install for Maintenance - Install the pump in a manner that allows easy access for inspection & maintenance. Connect plumbing to the pump using unions or easily removed couplings. Fig 2
- Keep The Pump Horizontal - The pump is designed to be installed on a relatively horizontal surface. If the mounting surface is not horizontal, the discharge should always be higher than the inlet. If not installed properly, the check valves will not work. The pump base can be rotated 180°. Fig 3

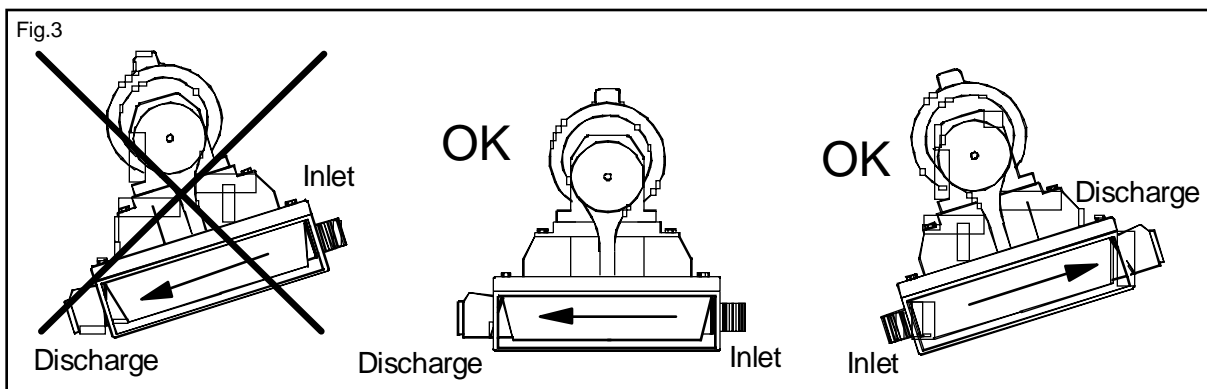
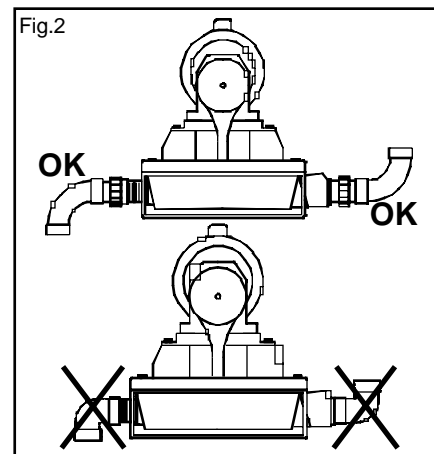
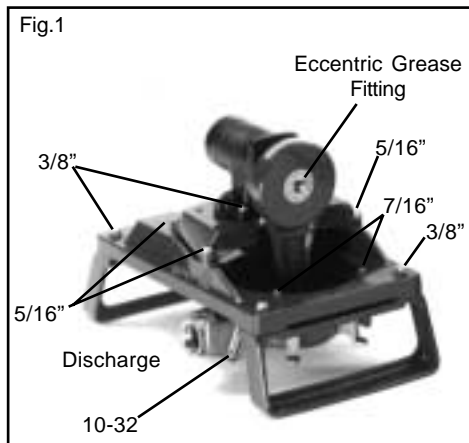

Important Plumbing Do & Don'ts

- **DO NOT SHUT OFF DISCHARGE WHEN THE PUMP IS RUNNING.** See Fig 4 - Do not place the pump in a situation where the discharge line will be closed while the pump is running. **BECAUSE** the Edson pump is a positive displacement pump and it will continue to try to pump liquid through a closed line. The pressure created will cause damage to the pump.
- **DISCHARGE FITTINGS, PIPE AND HOSE SHOULD ALL BE THE SAME SIZE AND NEVER BE SMALLER THAN THE INLET.** See Fig. 5 **BECAUSE** a smaller discharge line increases work for the pump and increases the possibility of clogging.
- **DO NOT INSTALL THE PUMP AND PLUMBING SO AIR WILL BE TRAPPED.** See Fig. 6 **BECAUSE** trapped air can completely restrict the flow or at the least require more work from the pump resulting in early diaphragm failure. Install pump and plumbing so any air introduced into the plumbing will not be trapped but flow naturally through liquid and out of the system.
- **SHOULD NOT INSTALL PUMP WITH POSITIVE HEAD ON THE INLET** See Fig. 7 - Under standard operating guidelines the pump should be above the liquid it is being used to transfer. **BECAUSE** of the flow through check valves, stopping the pump will not stop the liquid from flowing. Under the force of gravity liquid will pass right through a diaphragm pump. Also consider a diaphragm pump can not control a siphon condition. They are used many times to start one.

Use Only Non Collapsing Hose and Pipe On the Inlet and Discharge of the Pump

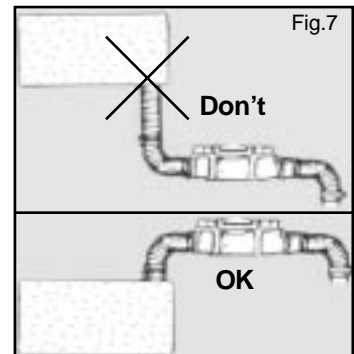
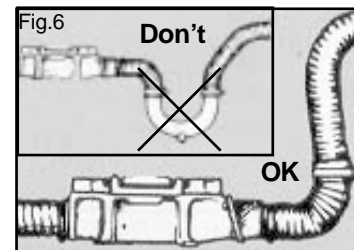
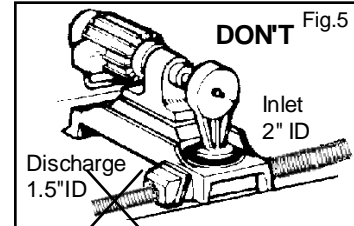
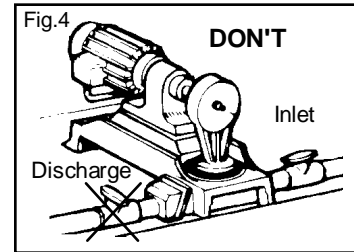

Self Priming:

The Bone Dry Pump will develop a dry start vacuum of 10 to 12 inches of mercury, equal to a height of approximately 12'. After the pump is primed the vacuum pressure will increase to 15" hg or more. The self priming feature depends on:

- An air tight suction line.
- The flapper check valves sealing properly.

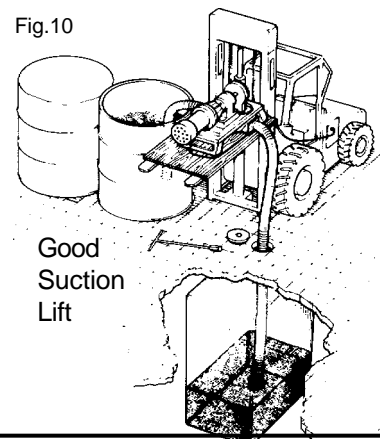
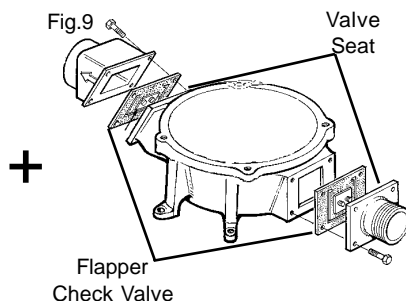
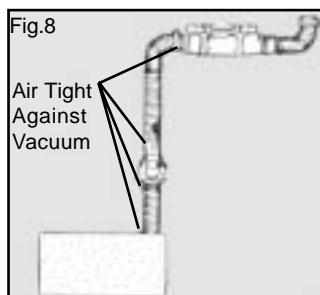

Running The Pump Dry:

The Bone Dry Pump will run dry indefinitely without damage.

Pumping Liquids with Suspended Solids:

- **KEEP SOLIDS IN SUSPENSION** - When the pump is used to pump solid matter such as sludge at the bottom of a tank or to dredge out a section of a lagoon make sure the solids have enough liquid mixed in to allow it to flow. Raking or stirring while the pump is pumping will keep solids in suspension. Rule of thumb in pumping viscous liquids or combinations of liquids with solids, "If It Will Not Flow Through A Line Under Gravity, The Pump Will Most Likely Not Pump It." See Fig.11
- **FLAPPER CHECK VALVES AND SOLIDS** - Solids trapped under the check valves will prevent self priming. This is likely to occur when the pump is used in sewage or sump pump out applications . Flushing with water will generally clear out the solid matter. Installing secondary clear flapper check valves right at the inlet and discharge will improve the dry suction start performance of the pump and make clearing the valves easy. Order Edson Clear Check Valves 269CL-200 (2") or 269CL-150 (1.5"). See Fig.12
- **PUMPING AT THE PROPER SPEED** - When pumping liquid with solids the speed may be too slow to keep the solids and the liquid combined. The solids will stop moving and begin to clog the line. Pumping at a faster rate or decreasing the hose size to increase velocity may be the solution. Check With Edson Customer Service.
- **USING A STRAINER ON THE INLET** - If the solids are too large they will block the inlet or get stuck in the suction line. The end a suction hose can become attached to a flat surface cutting off all flow. Using an Edson strainer will prevent these conditions. Order an Edson Shattedproof Bronze Strainer 111BR - 200 or 111BR - 150 See Fig.13
- **USING A DISCHARGE LOOP** - For sewage and sump applications when the discharge drains naturally down and away from the pump, installing a 8" to 10" positive loop right on the discharge port will improve the self priming feature. When you stop pumping the loop traps some liquid against the discharge valve improving the seal. See Fig.14

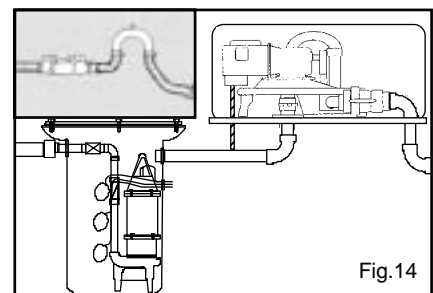
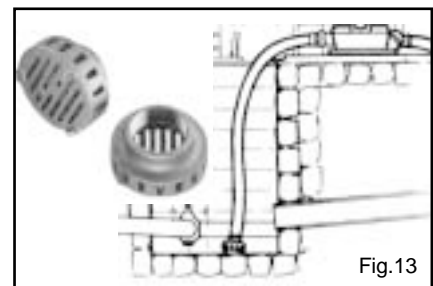
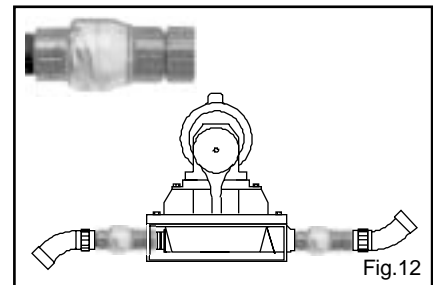
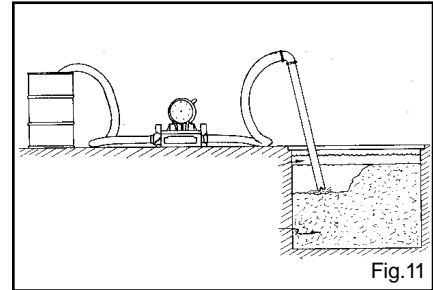

How The Pump Works

- The motor and gear reducer drive the eccentric disk inside the eccentric housing.
- The eccentric housing raises and lowers the diaphragm.
- Raising the diaphragm creating a vacuum. Fig.15
- The vacuum pulls the discharge valve assembly closed.
- Atmospheric pressure pushes liquid and/or air up the inlet plumbing to fill the vacuum.
- When the diaphragm is driven down the air and liquid under the diaphragm is compressed closing the inlet check valve and forcing the air and liquid out the discharge. Fig.16
- The closing of the inlet valve assembly also prevents the liquid and air trapped in the inlet line from dropping back down (to atmosphere).

Suction Stroke

Inlet Valve Assembly:
opens into the pump
Discharge Valve Assembly:
closes and seals on the valve
seat that is part of the pump
base under the discharge
chamber.

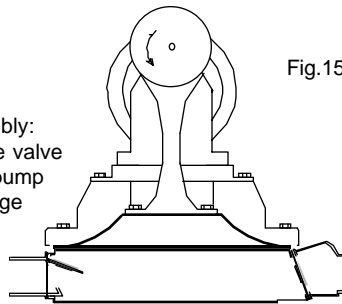

Fig.15

Discharge Stroke

Discharge Valve Assembly:
opens away from the pump
Inlet Valve Assembly:
closes and seals on the valve
seat that is part of the inlet
chamber.

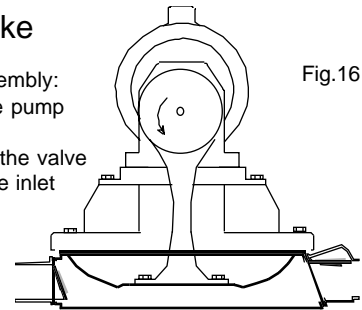

Fig.16

Pump Construction Information Is Defined By the Order # : Helpful when determining performance limits and ordering replacement parts for your model pump. **Example of Order # 220HLA 150**

- 1st Set - 220HLA specify the basic construction **H=Hydraulic, L=Skid Mounted, A= Aluminum**
220HLB **B=Bronze**
220HWA **W=Cart Mounted,**
220HWA **H=Hydraulic, W=Cart Mounted, B=Bronze**

Pictures

**Aluminum or Bronze is
the Metal of which the
Pump Chamber is Made**



Fig.18

- 2nd Set - 150 specify the size of the inlet 1.5" Male NPT & discharge as 1.5 " Female NPT
- Options - Ordered as separate items, they are listed as order #'s starting with **230**

230 Options include:

11318V Viton Rubber Diaphragm
A-1745 47 to 1 Ratio Gear Reducer
A-1744 57 to 1 Ratio Gear Reducer
A-1746 87 to 1 Ratio Gear Reducer
A-1299 Motor Guard

Pump Speed: What speed is best depends on the application, what type of liquid is being pumped and the head conditions. The following guidelines apply for this pump.

- Maximum Cycle Rate is 60 RPM on the output shaft of the gear reducer.
- The higher the viscosity the slower the pump. Viscous liquids need time to respond to pumping pressures.
- 1 1/4" ID plumbing requires pump speeds under 45 RPM.
- Small suction lines under 1" ID require speeds under 20 RPM.
- The higher the back pressure the slower the pump RPM.



Maintenance

Warning

Lock Out Electrical Service or Unplug the Pump Electrical Line, Before Performing Any Service. Failure to Do So Will Result In Bodily Injury

Diaphragm: Edson Pumps use Elastomer Diaphragm and Flapper Valves. These parts wear and are in need of periodic replacement. The ability to easily and quickly replace these inexpensive parts in the field is one of the major advantages of these pumps. Edson has packaged these parts as Spares Kits. See the parts list for the order #s.

- Change the diaphragm as required. Fig. 22
- Visual inspection on a regular bases is recommended.
- Continuous duty applications should be inspected daily until a life pattern is established.
- Look for leaks, cracks or splits on the surface of the diaphragm.
- Life expectancy is directly related to head conditions, run time and diaphragm material. The higher the suction and discharge pressures the shorter the life.

| | | |
|---|--|---|
| <p>Step 1. Unbolt Pump Base from Pump Frame with 7/16 wrench.</p>  <p>Fig.22</p> | <p>Step 2. Unbolt the Diaphragm from the Eccentric Housing and Lower Standard (STAINLESS STEEL BACKING PLATE) with 9/16 socket.</p>  | <p>Step 3. Reverse steps 1 & 2 to reassemble pump with new diaphragm and the 2 sealing washers on the 3/8" bolts.</p> <p>Important: Eccentric stays connected to the reducer. Lower Standard be installed with it's sharp edge away from the bottom of the diaphragm</p> <p>Tools Required: One 9/16 Socket Wrench with a 6" Extension Two 7/16 Box Wrench</p> |
|---|--|---|

Valve Assemblies & The Valve Seats: Together with the raising and lowering of the diaphragm, the sealing of the flapper valves are what make the diaphragm pump work. If the valves are not sealing properly, the pump will not be performing to full potential or may not be pumping at all. The valves tend to last longer than the diaphragm. When you change the diaphragm inspect the valves for cracks and delamination and the valve seats for pitting and any build up that will prevent the valve rubber from sealing effectively. Testing the pump is the best way to evaluate performance.

- Change the valve assemblies as required. Fig. 23
- Inspection and testing on a regular bases is recommended. For continuous duty application, inspect daily until a life pattern is established.
- See Pump Performance Tests (page 8) for how to test the pump.

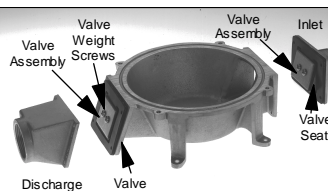
| | | |
|--|--|--|
| <p>Step 1. Unbolt the Inlet and the Discharge Chamber.</p> <p>Step 2. Inspect Valve Seats. Surfaces should be smooth, flat and free of foreign matter.</p> <p>Fig.23</p> |  | <p>Step 3. Resurface, if necessary. Use a flat belt sander or medium grade emery cloth wrapped on a flat piece of wood. It is important that the valve seat area remains flat.</p> <p>Step 4. Install New Valves. Insure Valve Weight Screws are Tight and Valves are Oriented Properly.</p> |
|--|--|--|

● **Volume Test - Tests overall performance of the pump installation.**

1. Use a container with a known capacity of at least 2 gallons.
2. Empty the container using the suction side of the pump or fill it from the discharge.
When using the fill test make sure the pump is fully primed before filling the container.
3. Use a watch to record the time it takes. Repeat the test at least twice.
4. Establish GPM rate. Example 1: It took 7 seconds to fill a 2 gallon container. The GPM rate is 17 Gallons Per Minute. (60 seconds divided by 7 seconds times 2 gal.)
Example 2: It took 35 seconds to empty a 2 gallon container. The GPM rate is 3.4 Gallons Per Minute. (60 seconds divided by 35 seconds times 2 gal.)
5. Record the cycle speed of the pump. Know the head conditions of your test and compare the results of your test with the volume of the appropriate Volume Chart on page 2. Every installation is different so use the charts as a guideline.
6. Example 1: The "fill test" at 17 GPM. The diaphragm is going up and down at 56 cycles per minute. The pump is approximately 6 ft. above the liquid. I disconnected the installation discharge line and replaced it with a 3 ft. length of 1.5" hose so I could do the fill test. Using the 56 cycle per minute Volume Chart from page 2, I know that at a suction height of 5 ft. and a discharge height of between 0 and 5 ft. I should get approximately 17 GPM. The installation is performing within the guide lines.
6. Example 2: The "empty test" at 3.4 GPM. The diaphragm is going up and down at 30 cycles per minute. The pump was approximately 5 ft. above the 2 gal. container and the discharge line goes up 4 ft. Using the 30 cycle per minute Volume Chart from page 2, I know that at a suction height of 5 ft. and a discharge height of between 0 and 5 ft. I should get approximately 5.5 GPM. The installation is performing below the guideline. For help in determining why, turn to Trouble Shooting page 9.

● **Vacuum Gauge Test - Tests the performance of the discharge valve and valve seat.**

1. Attach a 5' length of non-collapsing hose or pipe with a vacuum gauge installed to the inlet of the pump. Make sure the line is completely sealed and air tight.
2. Turn on the pump and let it run till the gauge stabilizes. Record the reading.
3. Turn off the pump and watch the gauge.
4. If the discharge is working properly the gauge should build and hold at 13" to 15"hg.
Do not be concerned if the vacuum pressure slowly returns to 0 within a minute or so.
5. If you do not get any vacuum reading or if the gauge does not get to 13" hg and drops off to 0 as soon as the pump stops, do the same thing again. Listen for air being sucked in around the diaphragm. If you hear air movement, inspect for loose bolts or worn diaphragm. If you hear no air movement, remove the discharge chamber and inspect the valve assembly and valve seat. Clean or replace the valve and clean or resurface the valve seat as appropriate. See Maintenance pg.7

● **Pressure Gauge Test - Tests the performance of the suction valve and valve seat.**

1. Attach a 5' length of non-collapsing hose or pipe with a 0 to 15 psi gauge installed to the outlet of the pump. Make sure the line is completely sealed and air tight.
2. Turn on the pump and let it run till the gauge stabilizes. Record the reading.
3. If the suction valve is working properly the gage should build and pulse at 7 to 8 psi. and when the pump is stopped the pressure may hold or slowly returns to 0.
4. If you do not get any pressure reading or if the gauge does not get to 4 psi and drops off to 0 as soon as the pump stops, clean or replace the suction valve and clean or resurface the valve seat as appropriate. See Maintenance/Valve Assemblies pg.7

● **Manual Test - Testing the pump valves and valve seats without the use of a gauge.**

1. Remove all fittings from the inlet and discharge of the pump.
2. Turn on the pump.
3. Put your hand over the inlet. If the discharge valve is working properly, you should feel a very strong pulsing suction. The pulsing coincides with the raising and lowering of the diaphragm. If you do not feel any suction, do the same thing again and listen for air being sucked in around the diaphragm. If you hear air movement, inspect for loose bolts or worn diaphragm. If you hear no air movement, remove the discharge chamber and inspect the valve assembly and valve seat. Clean or replace the valve and clean or resurface the valve seat as appropriate.
4. Press your hand over the discharge. If the inlet valve is sealing properly, the pressure of the pump down stroke should push your hand away. If it does not and the air is forced out the inlet remove the inlet chamber and inspect the valve assembly and valve seat. Clean or replace the valve and clean or resurface the valve seat as appropriate. See Maintenance/Valve Assemblies pg.7

Eccentric: A disk called an eccentric is pressed onto the output shaft of the gear reducer. As it rotates inside the bronze eccentric housing the diaphragm is raised and lowered. This assembly needs to be greased with any good gear grease. Edson applies **Mobil Grease HP Multipurpose Premium Grease** during the assembly of the pump. Failure to grease this part will result in early wear.

Trouble Shooting

The Edson Hydraulic Powered Diaphragm Pump is very simple and so problems are isolated to only the following components:

- **The Motor.**
- **The Eccentric.**
- **The Diaphragm and Valves.**
- **Suction and Discharge Plumbing.**

| 1.Problem | Possible Causes | Action |
|---|---|--|
| Pump is running, liquid is not moving. | a. Suction line is blocked. b. Suction line has air leak between liquid and inlet of the pump. c. Discharge and/or suction valves are not working. d. Diaphragm has a leak. e. Discharge or suction line is too high. | If the cause is not obvious, isolate the source. Disconnect the inlet and discharge plumbing from the pump and perform the Manual Test page 8. If the cause is not in the pump check for a block or an air leak in the suction line. Suction air leaks can be cumulative and can be as simple as one or two fittings not being sealed properly. Review Plumbing pages 4 to 5 |
| 2.Problem Motor is not coming on. | a. Check Hydraulic Pump . b. Motor worn out. | Check the hydraulic pump and the line for a blockage or restriction. Review the Performance Specifications and installation Guidelines for the hydraulic pump and motor. |
| 3.Problem Diaphragm is wearing out much earlier than expected. | a. Liquid being pumped is not compatible diaphragm material. b. Discharge and/or suction back pressure too high. | Consult a chemical resistance chart, review the Installation guide lines pages 2 to 5. Call Edson Customer Service. |
| 4.Problem Pump base and/or lines keep filling with solids. | a. Line velocity is too slow to keep the solids in suspension. b. The percent of solids is too high. | Speeding up the pump will help increase the velocity. Using a strainer can reduce the size and percent of solids. Diluting the slurry by increasing the amount of liquid or by increasing the agitation of the mix may solve the problem. Review Pumping Liquids with Suspended Solids page 5 |

Parts

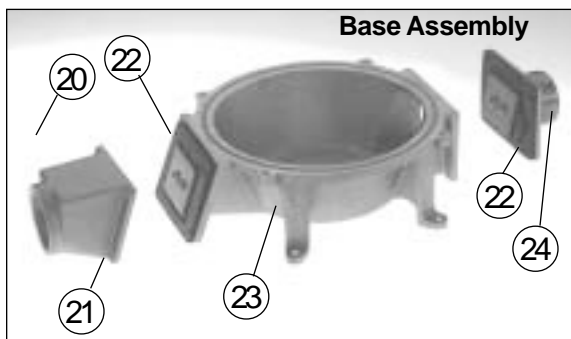
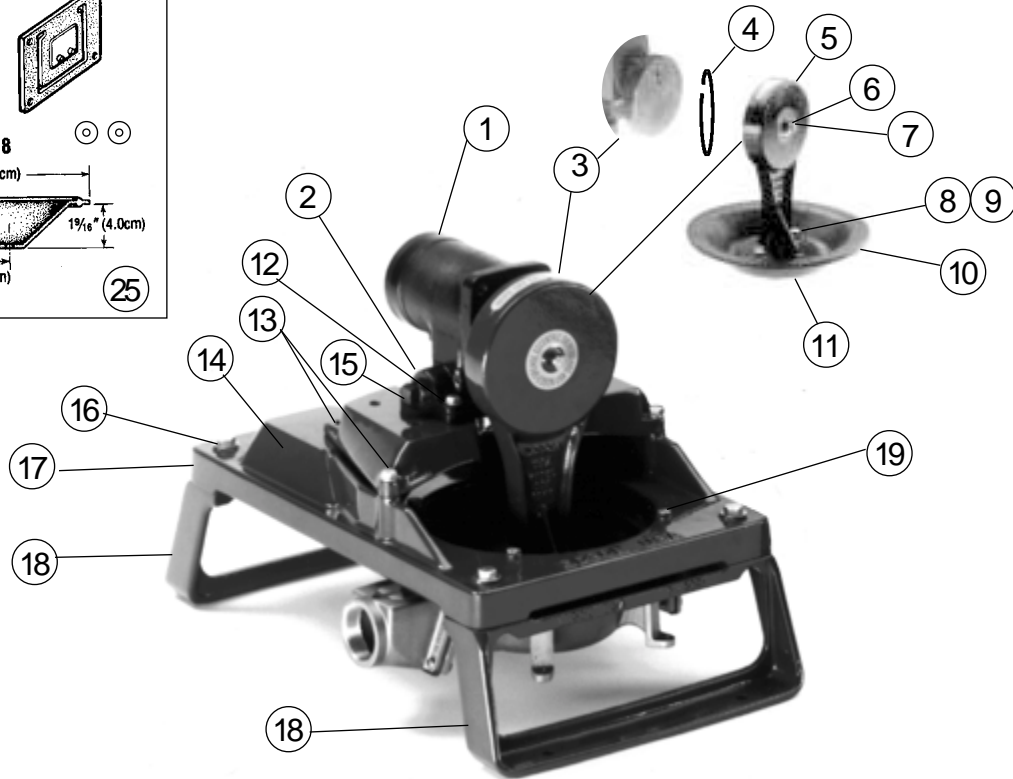
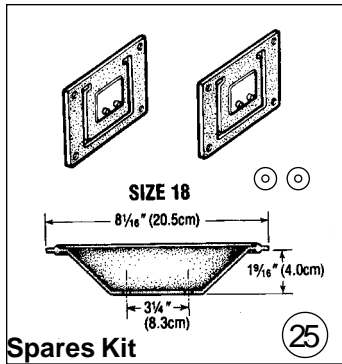

Parts List 220HLA-150

| | |
|----------------------|---|
| Edson Order # | Description |
| 220HLA -150 | Hydraulic Powered Diaphragm Pump, Skid Mounted, Aluminum, 1.5" MNPT Inlet and 1.5" FNPT Discharge |

| Key # | Edson Order # | Description | Qty |
|-------|--------------------|---|-----|
| 1 | 161-A-1077 | 5.9 Cubic Inch Char-Lynn H-Series Motor with 1/2" NPTF Connections Char-Lynn Part # 101-1019 | 1 |
| 2 | 161-A-1078 | Base Kit for Char-Lynn H-Series Motor Part # 123-1007 | 1 |
| 3 | 161-A-1697 | Eccentric Disk (included with Reducer key # 3) | 1 |
| 4 | 161-A-1161 | Snap Ring (included with Eccentric Housing key #6) | 1 |
| 5 | 161-C-508 | Eccentric Housing With Snap Ring (includes Zerk Fitting & Snap Ring key #s 6, 7, 8) | 1 |
| 6 | 161-A-150 | Zerk Grease Fitting (included with Eccentric Housing key #6) | 1 |
| 7 | 161-A-399 | Zerk Fitting Dust Cap (included with Eccentric Housing key #6) | 1 |
| 8 | 1/4-20X1" HHCS | Stainless Hex Head Cap Screws | 2 |
| 9 | 160-A-1204 | Sealing Washers | 2 |
| 10 | 113N-18 | Nitrile Diaphragm (This is the standard diaphragm. An optional diaphragm may have been installed on the pump. Check original invoice.) | 1 |
| 11 | 160-A-1006 | Lower Standard | 1 |
| 12 | 3/8"-16X1" HHCS | Stainless Hex Head Cap Screws | 4 |
| 13 | 5/16"-18X1.25"HHCS | Stainless Hex Head Cap Screws | 4 |
| 14 | 161-C-477 | Reducer Mounting Adapter Plate | 1 |
| 15 | 161-B-569 | Motor Spacer Plate | 1 |
| 16 | 3/8"-16X2.5" HHCS | Stainless Hex Head Cap Screws | 4 |
| 17 | 161-D-75 | Pump Frame | 1 |
| 18 | 161-C-389 | Pump Leg | 2 |
| 19 | 1/4"-20X1.5 HHCS | Stainless Hex Head Cap Screws with Washers | 4 |
| 20 | 10-32X1 PHMS | Stainless Pan Head Mach. Screws with Nuts and Washers | 8 |
| 21 | 160-B-376A-150 | Aluminum Discharge Chamber 1.5" | 1 |
| 22 | 160-A-1207 | Inlet/Discharge Valve Assembly | 2 |
| 23 | 160-B-378A | Aluminum Side Inlet Pump Base | 1 |
| 24 | 160-B-375A | Aluminum Suction Chamber 1.5" | 1 |
| 25 | 114N-18-200 | Compact Spares Kit Includes: Qty 1 - 113N-18 DIAPHRAGM (key # 3) Qty 2 - 160-A-1207 (key #27) Qty 2 - 160-A-1204 (key # 32) | |

Parts List 220HLB-150

| | |
|----------------------|--|
| Edson Order # | Description |
| 220HLB -150 | Hydraulic Powered Diaphragm Pump, Skid Mounted, Bronze, 1.5" MNPT Inlet and 1.5" FNPT Discharge |

| Key # | Edson Order # | Description | Qty |
|-------|--------------------|---|-----|
| 1 | 161-A-1077 | 5.9 Cubic Inch Char-lynn H-Series Motor with 1/2" NPTF Connections Char-Lynn Part # 101-1019 | 1 |
| 2 | 161-A-1078 | Base Kit for Char-Lynn H-Series Motor Part # 123-1007 | 1 |
| 3 | 161-A-1697 | Eccentric Disk (included with Reducer key # 3) | 1 |
| 4 | 161-A-1161 | Snap Ring (included with Eccentric Housing key #6) | 1 |
| 5 | 161-C-508 | Eccentric Housing With Snap Ring (includes Zerk Fitting & Snap Ring key #s 6, 7, 8) | 1 |
| 6 | 161-A-150 | Zerk Grease Fitting (included with Eccentric Housing key #6) | 1 |
| 7 | 161-A-399 | Zerk Fitting Dust Cap (included with Eccentric Housing key #6) | 1 |
| 8 | 1/4-20X1" HHCS | Stainless Hex Head Cap Screws | 2 |
| 9 | 160-A-1204 | Sealing Washers | 2 |
| 10 | 113N-18 | Nitrile Diaphragm (This is the standard diaphragm. An optional diaphragm may have been installed on the pump. Check original invoice.) | 1 |
| 11 | 160-A-1006 | Lower Standard | 1 |
| 12 | 3/8"-16X1" HHCS | Stainless Hex Head Cap Screws | 4 |
| 13 | 5/16"-18X1.25"HHCS | Stainless Hex Head Cap Screws | 4 |
| 14 | 161-C-477 | Reducer Mounting Adapter Plate | 1 |
| 15 | 161-B-569 | Motor Spacer Plate | 1 |
| 16 | 3/8"-16X2.5" HHCS | Stainless Hex Head Cap Screws | 4 |
| 17 | 161-D-75 | Pump Frame | 1 |
| 18 | 161-C-389 | Pump Leg | 2 |
| 19 | 1/4"-20X1.5 HHCS | Stainless Hex Head Cap Screws with Washers | 4 |
| 20 | 10-32X1 PHMS | Stainless Pan Head Mach. Screws with Nuts and Washers | 8 |
| 21 | 160-B-376B-150 | Bronze Discharge Chamber 1.5" | 1 |
| 22 | 160-A-1207 | Inlet/Discharge Valve Assembly | 2 |
| 23 | 160-B-378B | Bronze Side Inlet Pump Base | 1 |
| 24 | 160-B-375B | Bronze Suction Chamber 1.5" | 1 |
| 25 | 114N-18-200 | Compact Spares Kit Includes: Qty 1 - 113N-18 DIAPHRAGM (key # 3) Qty 2 - 160-A-1207 (key #27) Qty 2 - 160-A-1204 (key # 32) | |