

# Edson **GASOLINE POWERED DIAPHRAGM PUMP MODELS 220G**

## Installation and Operations Manual

**Index:**

Page 1	The Pump
Page 2	Performance & Dimensions
Page 3	Installation Guidelines
Page 5	Operations
Page 7	Maintenance & Repair
Page 9	Trouble Shooting
Page 10	Parts

### The Pump

A Model 220G can be purchased with a few options:

- Make sure the pump received is the pump ordered. Compare the pump with the packing list.
- Make sure the parts list attached to this manual is the one for your pump.
- Fill in the important pump information below

Turn to Page 6, Pump Construction Information, for details on comparing the pump with the Order #.



220GLB-150



220GWA-150

### ENTER YOUR PUMP DATA HERE

**SYSTEM SERIAL #**   
 From Edson Serial # Sticker On Pump Frame

**PUMP MODEL #**   
 From Packing Slip i.e.. 220GWB-150

**PUMP DRIVES:** Engine   
 Reducer   
 From Plates On Engine and Reducer. i.e. Briggs & Stratton 3.5

## Performance & Specifications

### Pump Performance Is Dependent On Cycle Rate & Installation Head:

- Volume is expressed in GPM (gallons per minute) and LPM (liters per minute)
- Cycle Rate is the rpm the engine is running at divided by the ratio of the reducer 57. If the engine is at full rpm approximately 3400, the cycle rate is 60 cycles per minute.
- Head conditions are determined by the height, length and size of the installation plumbing to and from the pump and the viscosity of the liquid.

### General Specifications:

- Static Head: Suction 18 ft / 5.48m Discharge 18 ft / 5.48m (1.5" Hose or Pipe)
- Dry Suction Head: 15 ft / 4.57m (1.5" ID Pipe or Hose)
- Continuous Duty Discharge Heads: Should be Limited to 10 ft. / 3m
- 18 GPM / 68.14 LPM at 5 ft Suction Lift and 0 Discharge at 56 Cycles per Min. w/ 1.5" Pipe

### Volume Charts:

- Use these as a guide to determine the performance to expect from the pump you are installing. Volumes are based on the suction height, discharge height and speed while pumping water through 1.5" pipe.

		DISCHARGE HEIGHT		
		0	5 feet 1.5 meters	10 feet 3 meters
S U C T I O N  H E I G H T	1 foot .3 meters	18 gpm 68.4 lpm	17 gpm 64.6 lpm	17 gpm 64.6 lpm
	5 feet 1.5 meters	17.5 gpm 66.5 lpm	17 gpm 64.6 lpm	15.5 gpm 59 lpm
	10 feet 3 meters	16.5 gpm 62.7 lpm	15 gpm 57 lpm	13.5 gpm 51.3 lpm
	17 feet 4.2 meters	6 gpm 22.8 lpm	5 gpm 19 lpm	4 gpm 15.2 lpm

		DISCHARGE HEIGHT		
		0	5 feet 1.5 meters	10 feet 3 meters
S U C T I O N  H E I G H T	1 foot .3 meters	12.9 gpm 49 lpm	12.1 gpm 46 lpm	12.1 gpm 46 lpm
	5 feet 1.5 meters	12.5 gpm 47.5 lpm	12.1 gpm 46 lpm	11 gpm 41.8 lpm
	10 feet 3 meters	11.8 gpm 44.8 lpm	10.7 gpm 40.7 lpm	9.6 gpm 36.5 lpm
	17 feet 4.2 meters	5 gpm 19 lpm	4 gpm 15 lpm	3 gpm 11.5 lpm

		DISCHARGE HEIGHT		
		0	5 feet 1.5 meters	10 feet 3 meters
S U C T I O N  H E I G H T	1 foot .3 meters	11.6 gpm 44.1 lpm	10.9 gpm 41.4 lpm	10.9 gpm 41.4 lpm
	5 feet 1.5 meters	11.3 gpm 42.9 lpm	10.9 gpm 41.4 lpm	10 gpm 38 lpm
	10 feet 3 meters	10.6 gpm 40.3 lpm	9.6 gpm 36.5 lpm	8.7 gpm 33.1 lpm
	17 feet 4.2 meters	5 gpm 19 lpm	4 gpm 15 lpm	3 gpm 11.5 lpm

		DISCHARGE HEIGHT		
		0	5 feet 1.5 meters	10 feet 3 meters
S U C T I O N  H E I G H T	1 foot .3 meters	7 gpm 26.5 lpm	6 gpm 22.8 lpm	5 gpm 19 lpm
	5 feet 1.5 meters	6 gpm 22.8 lpm	5.5 gpm 21 lpm	5 gpm 19 lpm
	10 feet 3 meters	5.5 gpm 21 lpm	5 gpm 19 lpm	5 gpm 19 lpm
	17 feet 4.2 meters	5 gpm 19 lpm	4 gpm 15 lpm	3 gpm 11.5 lpm

		DISCHARGE HEIGHT		
		0	5 feet 1.5 meters	10 feet 3 meters
S U C T I O N  H E I G H T	1 foot .3 meters	4.6 gpm 17.5 lpm	4 gpm 15.2 lpm	3.3 gpm 12.5 lpm
	5 feet 1.5 meters	4 gpm 15.2 lpm	3.6 gpm 13.7 lpm	3.3 gpm 12.5 lpm
	10 feet 3 meters	3.6 gpm 13.7 lpm	3.3 gpm 12.5 lpm	3.3 gpm 12.5 lpm
	17 feet 4.2 meters	3.3 gpm 12.5 lpm	2.7 gpm 10 lpm	2 gpm 7.6 lpm

		DISCHARGE HEIGHT		
		0	5 feet 1.5 meters	10 feet 3 meters
S U C T I O N  H E I G H T	1 foot .3 meters	3 gpm 11.4 lpm	2.6 gpm 10 lpm	2.2 gpm 8.4 lpm
	5 feet 1.5 meters	2.6 gpm 10 lpm	2.4 gpm 9.1 lpm	2.6 gpm 10 lpm
	10 feet 3 meters	2.4 gpm 9.1 lpm	2.6 gpm 10 lpm	2.6 gpm 10 lpm
	17 feet 4.2 meters	2.6 gpm 10 lpm	1.7 gpm 6.5 lpm	1.3 gpm 4.9 lpm

## Dimensions

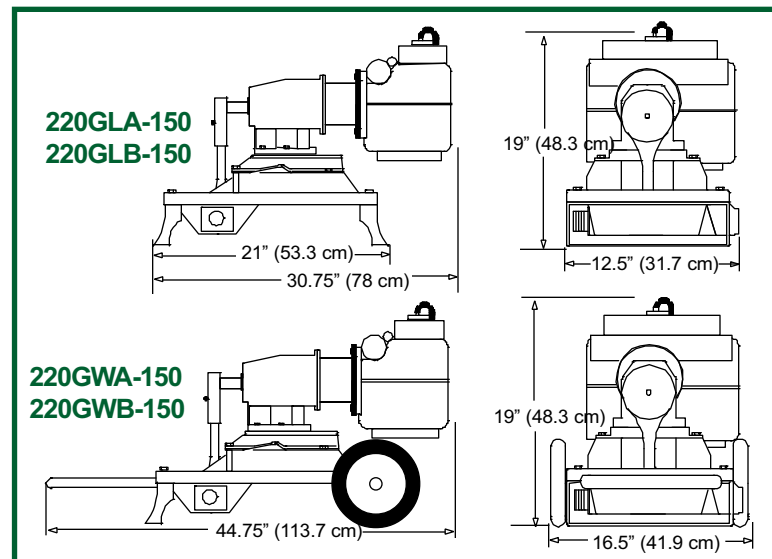

**IMPORTANT**

**Factory Engines Do Not Come With Oil.**

It is the responsibility of the purchaser to add oil to the engine crank case per the engine manufacturers specifications detailed in the enclosed engine manual.

**Failure to add oil to the engine prior to running the engine will destroy the engine**

**First Things First:**

- Check All Bolts - Make sure that all bolts on the pump are tight. Tools: 2ea. 9/16", 1/2" and 7/16" Box Wrenches. See Fig.1
- Install The Handle ( Cart Mounted Pumps Only ) - Remove spacers & replace with handle.
- Check Eccentric for Grease - See instruction labels on pump. See Fig. 1 & Eccentric pg.9
- Plumbing Fittings - Use only large radius elbows and remember No aluminum fittings on a bronze pump and No bronze fittings on an aluminum pump. See Fig. 2
- Install for Maintenance - Install the pump in a manner that allows easy access for inspection & maintenance. Connect plumbing to the pump using unions or easily removed couplings.
- Keep The Pump Horizontal - The pump is designed to be installed on a relatively horizontal surface. If the mounting surface is not horizontal, the discharge should always be higher than the inlet. If not installed accordingly the check valves will not work. The pump base can be rotated 180°. See Fig 3

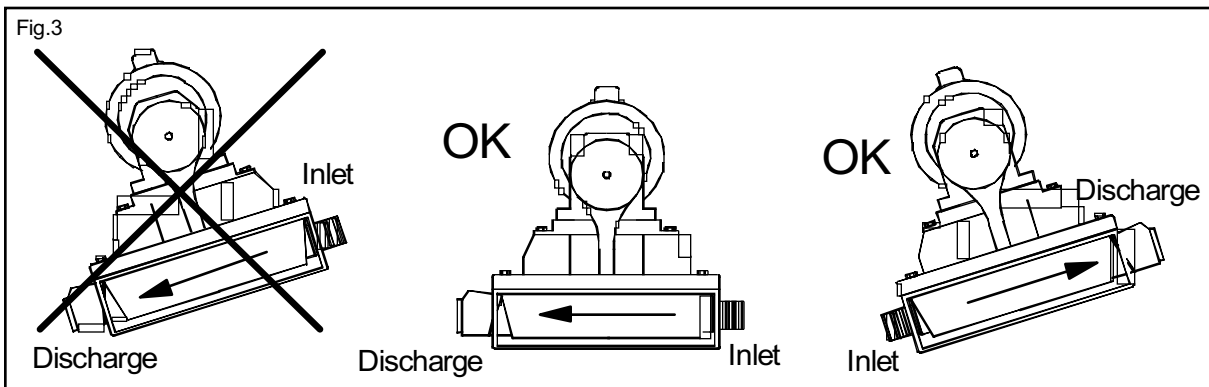
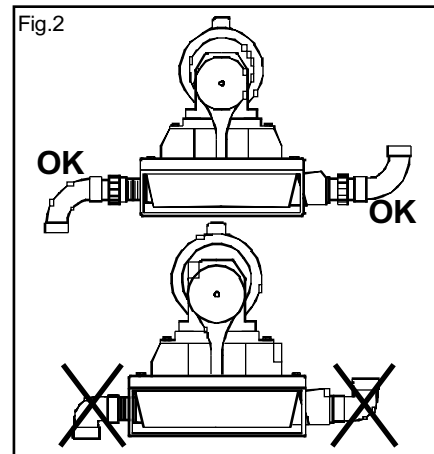
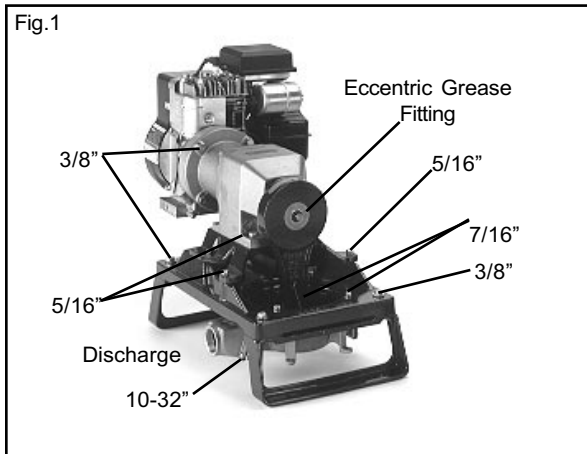

- DO NOT SHUT OFF DISCHARGE WHEN THE PUMP IS RUNNING. See Fig 4 - Do not place the pump in a situation where the discharge line will be closed while the pump is running. BECAUSE the Edson pump is a positive displacement pump and it will continue to try to pump liquid through a closed line. The pressure created will cause damage to the pump.
- DISCHARGE FITTINGS, PIPE AND HOSE SHOULD ALL BE THE SAME SIZE AND NEVER BE SMALLER THAN THE INLET. See Fig. 5 BECAUSE a smaller discharge line increases work for the pump and increases the possibility of clogging.
- DO NOT INSTALL THE PUMP AND PLUMBING SO AIR WILL BE TRAPPED. See Fig. 6 BECAUSE trapped air can completely restrict the flow or at the least require more work from the pump resulting in early diaphragm failure. Install pump and plumbing so any air introduced into the plumbing will not be trapped but flow naturally through liquid and out of the system.
- SHOULD NOT INSTALL PUMP WITH POSITIVE HEAD ON THE INLET See Fig. 7 - Under standard operating guidelines the pump should be above the liquid it is being used to transfer. BECAUSE of the flow through check valves, stopping the pump will not stop the liquid from flowing. Under the force of gravity liquid will pass right through a diaphragm pump. Also consider a diaphragm pump can not control a siphon condition. They are used many times to start one.

**Use Only Non Collapsing Hose and Pipe On the Inlet and Discharge of the Pump**

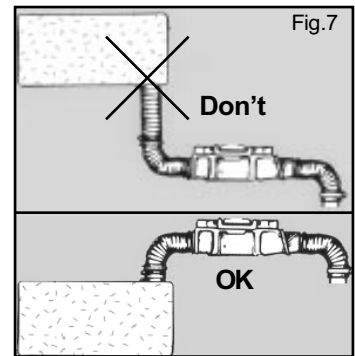
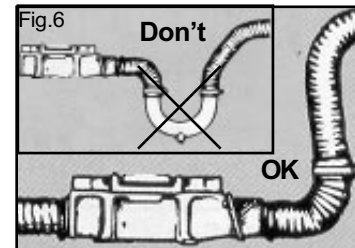
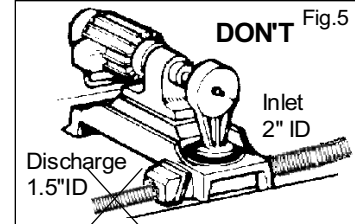
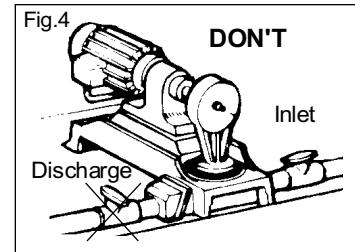

**Self Priming:**

The Bone Dry Pump will develop a dry start vacuum of 10 to 12 inches of mercury, equal to a height of approximately 12'. After the pump is primed the vacuum pressure will increase to 15" hg or more. The self priming feature depends on:

- An air tight suction line.
- The flapper check valves sealing properly.

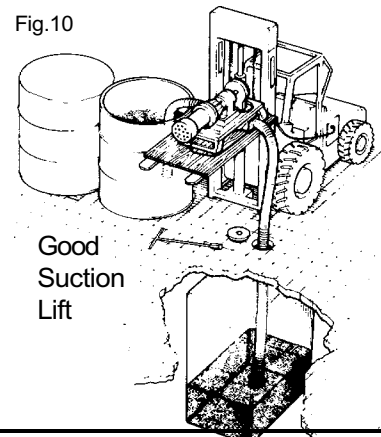
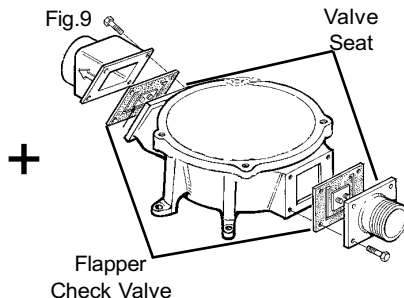
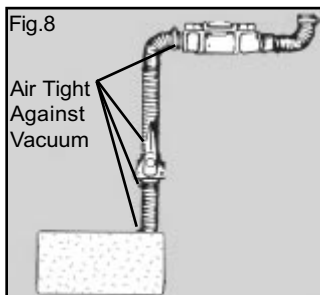

## Operation

### Running The Pump Dry:

The Bone Dry Pump will run dry indefinitely without damage.

### Pumping Liquids with Suspended Solids:

- **KEEP SOLIDS IN SUSPENSION** - When the pump is used to pump solid matter such as sludge at the bottom of a tank or to dredge out a section of a lagoon make sure the solids have enough liquid mixed in to allow it to flow. Raking or stirring while the pump is pumping will keep solids in suspension. Rule of thumb in pumping viscous liquids or combinations of liquids with solids, "If It Will Not Flow Through A Line Under Gravity, The Pump Will Most Likely Not Pump It." See Fig.11
- **FLAPPER CHECK VALVES AND SOLIDS** - Solids trapped under the check valves will prevent self priming. This is likely to occur when the pump is used in sewage or sump pump out applications . Flushing with water will generally clear out the solid matter. Installing secondary clear flapper check valves right at the inlet and discharge will improve the dry suction start performance of the pump and make clearing the valves easy. Order Edson Clear Check Valves 269CL-200 (2") or 269CL-150 (1.5"). See Fig.12
- **PUMPING AT THE PROPER SPEED** - When pumping liquid with solids the speed may be too slow to keep the solids and the liquid combined. The solids will stop moving and begin to clog the line. Pumping at a faster rate or decreasing the hose size to increase velocity may be the solution. Check With Edson Customer Service.
- **USING A STRAINER ON THE INLET** - If the solids are too large they will block the inlet or get stuck in the suction line. The end of a suction hose can become attached to a flat surface cutting off all flow. Using an Edson strainer will prevent these conditions. Order an Edson Shatter proof Bronze Strainer 111BR - 200 or 111BR - 150 See Fig.13
- **USING A DISCHARGE LOOP** - For sewage and sump applications when the discharge drains naturally down and away from the pump, installing a 8" to 10" positive loop right on the discharge port will improve the self priming feature. When you stop pumping the loop traps some liquid against the discharge valve improving the seal. See Fig.14

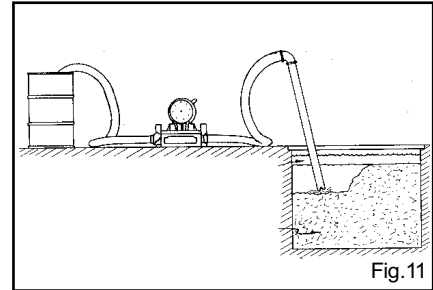

Fig.11

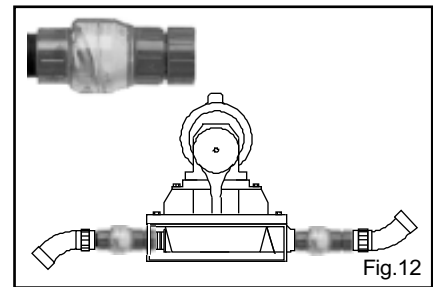

Fig.12

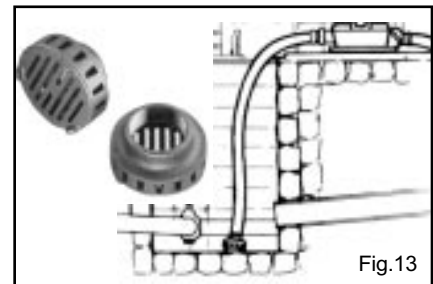

Fig.13

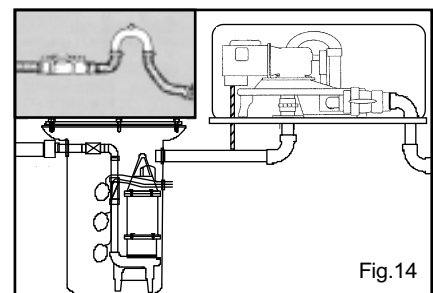

Fig.14

- The engine and gear reducer rotate the eccentric disk inside the eccentric housing.
- The eccentric housing raises and lowers the diaphragm.
- Raising the diaphragm creates a vacuum. See Fig.15
- The vacuum pulls the discharge valve assembly closed.
- Atmospheric pressure pushes liquid and/or air up the inlet plumbing to fill the vacuum.
- When the diaphragm is driven down the air and liquid under the diaphragm is compressed closing the inlet check valve and forcing the air and liquid out the discharge. Fig.16
- The closing of the inlet valve assembly also prevents the liquid and air trapped in the inlet line from dropping back down (to atmosphere).

**Suction Stroke**

Inlet Valve Assembly:  
opens into the pump

Discharge Valve Assembly:  
closes and seals on the valve  
seat that is part of the pump  
base under the discharge  
chamber.

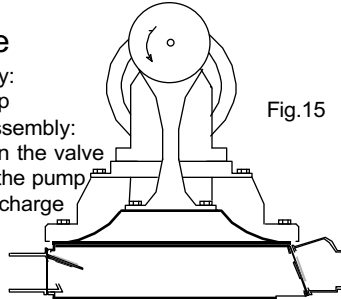

Fig.15

**Discharge Stroke**

Discharge Valve Assembly:  
opens away from the pump

Inlet Valve Assembly:  
closes and seals on the valve  
seat that is part of the inlet  
chamber.

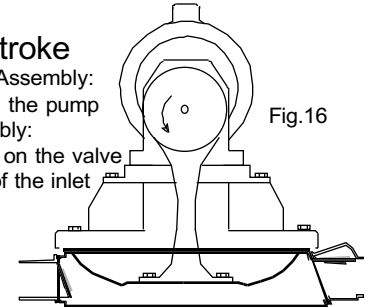

Fig.16

**Pump Construction Information Is Defined By the Order #** : Helpful when determining performance limits and ordering replacement parts for your model pump. **Example of Order # 220GLA-150**

- 1st Set - 220GLA specify the basic construction **G=Gasoline, L=Skid Mounted, A= Aluminum**  
 220GLB G=Gasoline, L =Skid Mounted, B=Bronze  
 220GWA G=Gasoline, W=Cart Mounted, A=Aluminum  
 220GWB G=Gasoline, W=Cart Mounted, B=Bronze



Fig.17

**Aluminum or Bronze is the Metal of which the Pump Chamber is Made**



Fig.19

Fig.18

150 specifies the size of the inlet 1 1/2" Male NPT & discharge as 1 1/2" Female

NPT.

- Options - Order as separate items. They are listed as order #'s starting with **230** or **231** followed by the part number and a description.

**Options**

Option order # is added to the basic pump order #, ie 220GWB-200 w/230-1130V

Option Description	Order #	Option Description	Order #
Starter Contact/Timer with 24 Volt Trans	230-A-2000	1/2hp, 60 hz, 1725 rpm, 110/220v, 1 ph, ex proof	231-A-1424
Remote Sop/Start Control	230-G-215	1/2hp, 60 hz, 1725 rpm, 220/440v, 3 ph, tefc	231-A-1383
Viton Diaphragm & Valves	230-1130V	1/2hp, 60 hz, 1725 rpm, 220/440v, 3 ph, exproof	231-A-1425
Hypalon Diaphragm & Valves	230-1130H	3/4hp, 12 volt, DC, tefc	231-A-1432
Polyurethane Coating	230-PC	3/4hp, 24 volt, DC, tefc	231-A-1433
Halar Coating	230-Halar	1/2hp, 12 volt, DC, tefc	231-A-1426
		1/2hp, 24 volt, DC, tefc	231-A-1427
<b>Optional Motors</b>		Special 50 hz Motors	
3/4hp, VARIABLE, 60/ 50 hz ,110v, 1 ph, tefc	231-A-1211	3/4hp, 50 hz, 2850 rpm, 110/220v, 1 ph, exproof	231-A-1500
3/4hp, 60 hz, 1725 rpm, 110/220v,1 ph, tefc	231-A-161	3/4hp, 50 hz, 2850 rpm, 110/220v, 1 ph. tefc	231-A-1501
3/4hp, 60 hz, 1725 rpm, 110/220v,1 ph, ex proof	231-A-1430	3/4hp, 50 hz, 2850 rpm, 220/440v, 3 ph, exproof	231-A-1556
3/4hp, 60 hz, 1725 rpm, 220/440v, 3 ph, tefc	231-A-1429	3/4hp, 50 hz, 1425 rpm, 220/440v, 3 ph, exproof	231-A-1557
3/4hp, 60 hz, 1725 rpm, 220/440v, 3 ph, exproof	231-A-1431	3/4hp, 50 hz, 1425 rpm, 110/220v, 1 ph. tefc	231-A-1558
1/2hp, 60 hz, 1725 rpm, 110/220v, 1 ph, tefc	231-A-1382	3/4hp, 50 hz, 2850 rpm, 220/440v, 3 ph, tefc	231-A-1559
		3/4hp, 50 hz, 1425 rpm, 220/440v, 3 ph, tefc	231-A-1560



The 220G Pump can be powered by an electric motor. The above motors can be used. In order to evaluate the performance of the pump powered by an electric motor, determine the cycle rate of the pump. The cycle rate is based on the motor rpm divided by 57.



**Pump Speed:** The proper speed depends on the application, what type of liquid is being pumped and the head conditions. The following guidelines apply for this pump.

- Maximum Cycle Rate is 60 RPM on the output shaft of the gear reducer.
- The higher the viscosity the slower the pump. Viscous liquids need time to respond to pumping pressures.
- Small suction lines under 1 1/2" ID require speeds under 30 RPM.
- The higher the back pressure the slower the pump RPM.

## Maintenance

**Diaphragm:** Edson 220 Pumps use Elastomer Diaphragm and Flapper Valves. Over time these parts wear and need to be replaced. The ability to easily and quickly replace these inexpensive parts is one of the major advantages of an Edson diaphragm pump. Edson has packaged these parts as Spares Kits. See the parts list for the order #s.

- Change the diaphragm as required. See Fig. 22
- Inspection and testing on a regular basis is recommended. For continuous duty application, inspect the pump daily until a life pattern is established.
- Look for leaks, cracks or splits on the surface of the diaphragm.
- Life expectancy is directly related to head conditions, run time and diaphragm material. The higher the suction and discharge pressures the shorter the life.

<p><b>Step 1.</b> Unbolt Pump Base from Pump Frame with 7/16" wrench.</p>  <p>Fig.22</p>	<p><b>Step 2.</b> Unbolt the Diaphragm from the Eccentric Housing and Lower Standard (STAINLESS STEEL BACKING PLATE) with 7/16" socket.</p> 	<p><b>Step 3.</b> Reverse steps 1 &amp; 2 to reassemble pump with new diaphragm and the 2 sealing washers on the 1/4" bolts.</p> <p><b>Important:</b> Eccentric stays connected to the reducer. Lower Standard must be installed with its sharp edge away from the bottom of the diaphragm</p> <p>Tools Required: 7/16" Socket Wrench with a 6" Extension (2) 7/16" Box Wrench</p>
--	---	--

**Valve Assemblies & The Valve Seats:** The sealing of the flapper valves are what makes the diaphragm pump work. If the valves are not sealing properly, the pump will not be performing to full potential or may not be pumping at all. The valves tend to last longer than the diaphragm. When you change the diaphragm inspect the valves for cracks and delamination and the valve seats for pitting and any build up that will prevent the valve rubber from sealing effectively. Testing the pump is the best way to evaluate performance.

- Change the valve assemblies as required. See Fig. 23
- Inspection and testing on a regular basis is recommended. For continuous duty application, inspect the pump daily until a life pattern is established.
- See Pump Performance Tests (Page 8).

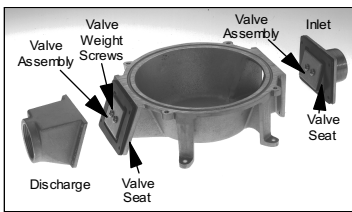
<p><b>Step 1.</b> Unbolt the Inlet and the Discharge Chamber.</p> <p><b>Step 2.</b> Inspect Valve Seats. Surfaces should be smooth, flat and free of foreign matter.</p> <p>Fig.23</p>		<p><b>Step 3.</b> Resurface, if necessary. Use a flat belt sander or medium grade emery cloth wrapped on a flat piece of wood. It is important that the valve seat area remains flat.</p> <p><b>Step 4.</b> Install new valves. Insure valve weight screws are tight and valves are oriented properly.</p>
--	--	--

● **Volume Test - Tests overall performance of the pump installation.**

1. Use a container with a known capacity of at least 2 gallons.
2. Empty the container using the suction side of the pump or fill it from the discharge.  
When using the fill test make sure the pump is fully primed before filling the container.
3. Use a watch to record the time it takes. Repeat the test at least twice.
4. Establish GPM rate. Example 1: It took 10 seconds to fill a 2 gallon container. The GPM rate is 12 Gallons Per Minute.(60 seconds divided by 10 seconds times 2 gal.)  
Example 2: It took 10 seconds to empty a 2 gallon container. The GPM rate is 12 Gallons Per Minute.(60 seconds divided by 10 seconds times 2 gal.)
5. Record the cycle speed of the pump. Know the head conditions of your test and compare the results of your test with the volume of the appropriate Volume Chart on page 2. Every installation is different so use the charts as a guideline.
6. Example 1: The "fill test" at 12 GPM. The diaphragm is going up and down at 40 cycles per minute. The pump is approximately 6 ft. above the liquid. I disconnected the installation discharge line and replaced it with a 3 ft. length of 1/2" hose so I could do the fill test. Using the 40 cycle per minute Volume Chart from page 2, I know that at a suction height of 5 ft. and a discharge height of between 0 and 5 ft. I should get approximately 12 GPM. The installation is performing within the guidelines.
6. Example 2: The "empty test" at 12 GPM. The diaphragm is going up and down at 40 cycles per minute. The pump was approximately 5 ft. above the 2 gal. container and the discharge line goes up 4 ft. From the 30 cycle per minute Volume Chart on page 2, I know that with a suction height of 5 ft. and a discharge height of 0 to 5 ft. I should get approximately 12 GPM. The installation is performing below the guidelines. See the Trouble Shooting section of this manual.

● **Vacuum Gauge Test - Tests the performance of the discharge valve and valve seat.**

1. Attach a 5' length of non-collapsing hose or pipe with a vacuum gauge installed to the inlet of the pump. Make sure the line is completely sealed and air tight.
2. Turn on the pump and let it run till the gauge stabilizes. Record the reading.
3. Turn off the pump and watch the gauge.
4. If the discharge is working properly the gauge should build and hold at 12" to 14"hg.  
Do not be concerned if the vacuum pressure slowly returns to 0 within a minute or so.
5. If you do not get any vacuum reading or if the gauge does not get to 10" hg and drops off to 0 as soon as the pump stops, do the same thing again. Listen for air being sucked in around the diaphragm. If you hear air movement, inspect for loose bolts or worn diaphragm. If you hear no air movement, remove the discharge chamber and inspect the valve assembly and valve seat. Clean or replace the valve and clean or resurface the valve seat as appropriate. See Maintenance/Valve Assemblies pg.7

● **Pressure Gauge Test - Tests the performance of the suction valve and valve seat.**

1. Attach a 5' length of non-collapsing hose or pipe with a 0 to 15 psi gauge installed to the outlet of the pump. Make sure the line is completely sealed and air tight.
2. Turn on the pump and let it run till the gauge stabilizes. Record the reading.
3. If the suction valve is working properly the gauge should build and pulse at 6 to 7 psi. and when the pump is stopped the pressure may hold or slowly return to 0.
4. If you do not get any pressure reading or if the gauge does not get to 4 psi and drops off to 0 as soon as the pump stops, clean or replace the suction valve and clean or resurface the valve seat as appropriate. See Maintenance/Valve Assemblies pg.7

● **Manual Test - Testing the pump valves and valve seats without the use of a gauge.**

1. Remove all fittings from the inlet and discharge of the pump.
2. Turn on the pump.
3. Put your hand over the inlet. If the discharge valve is working properly, you should feel a very strong pulsing suction. The pulsing coincides with the raising and lowering of the diaphragm. If you do not feel any suction, do the same thing again and listen for air being sucked in around the diaphragm. If you hear air movement, inspect for loose bolts or worn diaphragm. If you hear no air movement, remove the discharge chamber and inspect the valve assembly and valve seat. Clean or replace the valve and clean or resurface the valve seat as appropriate.
4. Press your hand over the discharge. If the inlet valve is sealing properly, the pressure of the pump down stroke should push your hand away. If it does not and the air is forced out the inlet remove the inlet chamber and inspect the valve assembly and valve seat. Clean or replace the valve and clean or resurface the valve seat as appropriate. See Maintenance/Valve Assemblies pg.7

**Eccentric:** A disk called an eccentric is pressed onto the output shaft of the gear reducer. As it rotates inside the bronze eccentric housing the diaphragm is raised and lowered. This assembly needs to be greased with any good gear grease. Edson applies **Mobil Grease HP Multipurpose Premium Grease** during the assembly of the pump. Failure to grease this part will result in early wear.

## Trouble Shooting

The Edson Gasoline Powered Diaphragm Pump is very simple and problems are isolated to only the following components:

- **The Engine & Gear Reducer**
- **The Gear Reducer and Eccentric**
- **The Diaphragm and Valves**
- **Suction and Discharge Plumbing**

1.Problem Pump is running, liquid is not moving.	Possible Causes a. Suction line is blocked. b. Suction line has air leak between liquid and inlet of the pump. c. Discharge and/or suction valves are not working. d. Diaphragm has a leak. e. Discharge or suction line is too high.	Action If the cause is not obvious, isolate the source. Disconnect the inlet and discharge plumbing from the pump and perform the Manual Test page 8. If the cause is not in the pump check for a block or an air leak in the suction line. Suction air leaks can be cumulative and can be as simple as one or two fittings not being sealed properly. Review Plumbing pages 4 to 5
2.Problem Engine is starting.	Possible Causes a. See Engine Manual.	Action See Engine Manual.
3.Problem Engine is running but reducer is not moving	Possible Cause a. Reducer Coupling has come loose on the motor shaft.	Action Remove the motor and reposition and secure the coupling to the motor shaft. See parts diagram for positioning instructions.
4.Problem Diaphragm is wearing out much earlier than expected.	Possible Causes a. Liquid being pumped is not compatible with the diaphragm material. b. Discharge and/or suction back pressure too high.	Action Consult a chemical resistance chart, review the Installation Guidelines pages 2 to 5. Call Edson Customer Service.
5.Problem Pump base and/or lines keep filling with solids	Possible Causes a. Line velocity is too slow to keep the solids in suspension. b. The percent of solids is too high.	Action Speeding up the pump will help increase the velocity. Using a strainer can reduce the size and percent of solids. Diluting the slurry by increasing the amount of liquid or by increasing the agitation of the mix may solve the problem. Review Pumping Liquids with Suspended Solids page 5

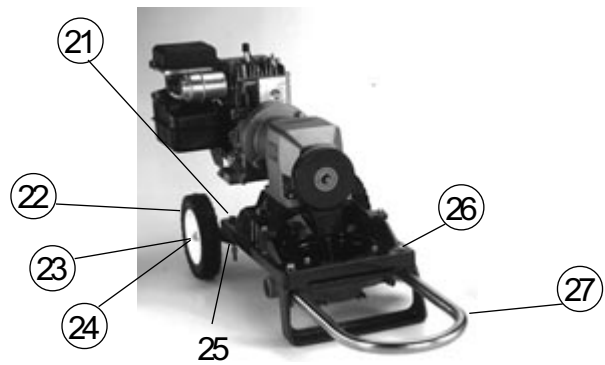
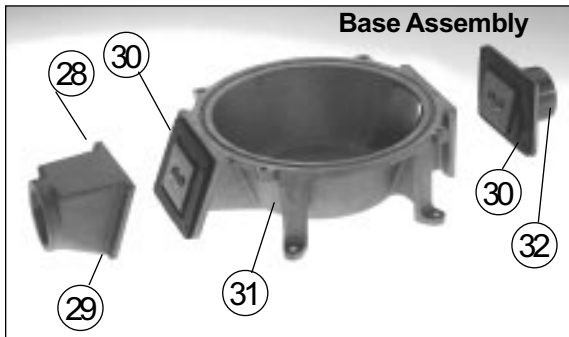
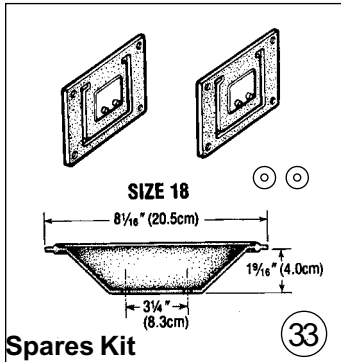
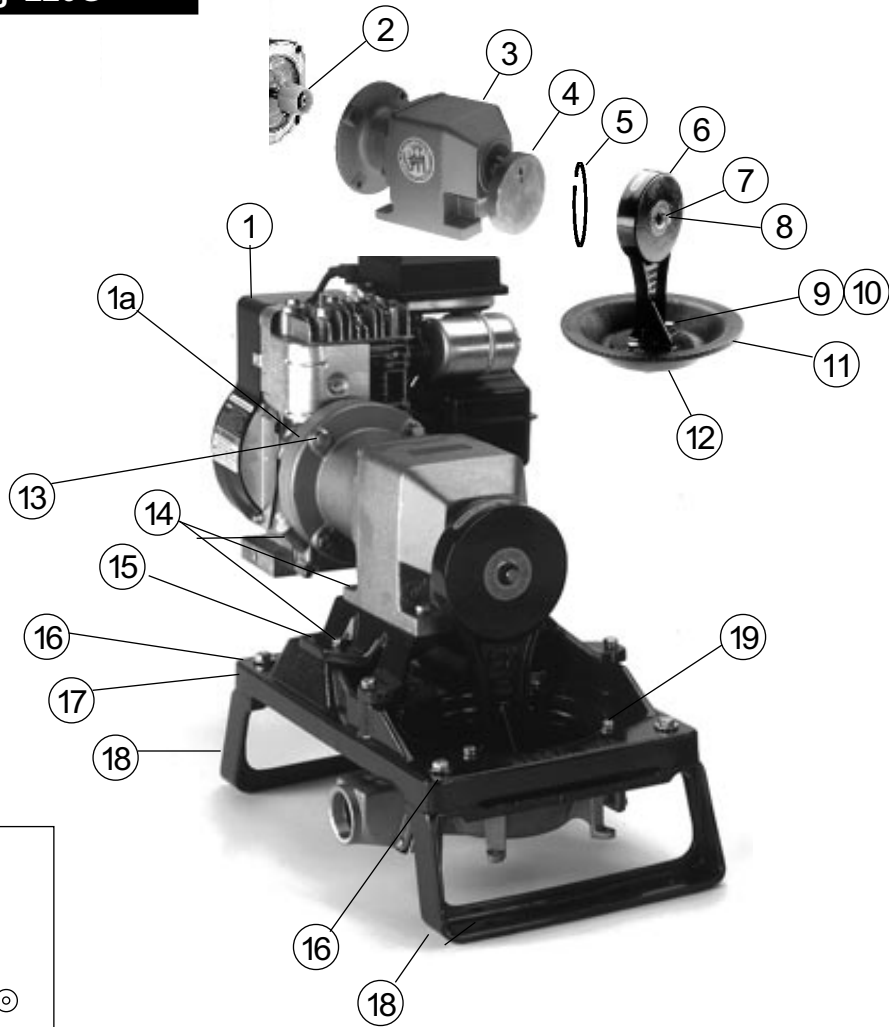

## Parts List 220GLA- 150

P-220GLA-00

<b>Edson Order #</b>	<b>Description</b>
220ELA-10-150	Compact Electric Diaphragm Pump, Skid Mounted, Aluminum, 1.5" MNPT Inlet and 1.5" FNPT Discharge

Key #	Edson Order #	Description	Qty
1	161-A-1385	Gasoline Engine, 3.5 HP	1
1a.	161-B-617	Adapter-Gas Engine to C-Face Mounting Adapter	1
2	161-A-1811-2	Motor Coupling for A-1744 Reducer (included with Reducer key #3)	1
3	161-A-1744	57 to 1 C-Face Gear reducer and coupling (includes Motor Coupling & Eccentric Disk key #s 2 & 4)	1
4	161-A-1697	Eccentric Disk (included with Reducer key # 3)	1
5	161-A-1161	Snap Ring (included with Eccentric Housing key #6)	1
6	161-C-508	Eccentric Housing With Snap Ring (includes Zerk Fitting & Snap Ring key #s 6, 7, 8)	1
7	161-A-150	Zerk Grease Fitting (included with Eccentric Housing key #6)	1
8	161-A-399	Zerk Fitting Dust Cap (included with Eccentric Housing key #6)	1
9	1/4-20X1" HHCS	Stainless Hex Head Cap Screws	2
10	160-A-1204	Sealing Washers	2
11	113N-18	Nitrile Diaphragm (This is the standard diaphragm. An optional diaphragm may have been installed on the pump. Check original invoice.)	1
12	160-A-1006	Lower Standard	1
13	3/8"-16X1" HHCS	Stainless Hex Head Cap Screws	8
14	5/16"-18X1.25"HHCS	Stainless Hex Head Cap Screws	4
15	161-C-583	Reducer Mounting Adapter Plate	1
16	3/8"-16X2.5" HHCS	Stainless Hex Head Cap Screws	4
17	161-D-75	Pump Frame	1
18	161-C-389	Pump Leg	2
19	1/4"-20X1.5 HHCS	Stainless Hex Head Cap Screws with Washers	4
20	161-A-1299	Motor Guard (Optional part installed only when ordered)	0
21	161-A-164	Axle Hanger	0
22	161-A-166	Wheel	0
23	161-A-143	Pal Nut	0
24	161-A-165	Stainless Axle	0
25	3/8"-16X4" HHCS	Stainless Hex Head Cap Screws with Nuts and Washers	0
26	3/8"-16X3" HHCS	Stainless Hex Head Cap Screws with Nuts and Washers	0
27	161-A-147	Pump Handle	0
28	10-32X1 PHMS	Stainless Pan Head Mach. Screws with Nuts and Washers	8
29	160-B-376A-150	Aluminum Discharge Chamber 1.5"	1
30	160-A-1207	Inlet/Discharge Valve Assembly	2
31	160-B-378A	Aluminum Side Inlet Pump Base	1
32	160-B-375A	Aluminum Suction Chamber 1.5"	1
33	114N-18-200	Compact Spares Kit	

Includes: Qty 1 - 113N-18 DIAPHRAGM (key # 3)

Qty 2 - 160-A-1207 (key #27)

Qty 2 - 160-A-1204 (key # 32)



## Parts List 220GLB-150

P-220GLB-150

<b>Edson Order #</b>	<b>Description</b>
220ELB-10-150	Compact Electric Diaphragm Pump, Skid Mounted, Bronze, 1.5" MNPT Inlet and 1.5" FNPT Discharge

Key #	Edson Order #	Description	Qty
1	161-A-1382	1/2 HP, 1725 RPM, 120/240V, 60HZ, TEFC, Electric Motor  (This is the standard motor. An optional motor may have been installed on the pump. Check legend plate on the motor.)	1
2	161-A-1811-2	Motor Coupling for A-1744 Reducer (included with Reducer key #3)	1
3	161-A-1744	57 to 1 C-Face Gear reducer and coupling (includes Motor Coupling & Eccentric Disk key #s 2 & 4)	1
4	161-A-1697	Eccentric Disk (included with Reducer key # 3)	1
5	161-A-1161	Snap Ring (included with Eccentric Housing key #6)	1
6	161-C-508	Eccentric Housing With Snap Ring (includes Zerk Fitting & Snap Ring key #s 6, 7, 8)	1
7	161-A-150	Zerk Grease Fitting (included with Eccentric Housing key #6)	1
8	161-A-399	Zerk Fitting Dust Cap (included with Eccentric Housing key #6)	1
9	1/4-20X1" HHCS	Stainless Hex Head Cap Screws	2
10	160-A-1204	Sealing Washers	2
11	113N-18	Nitrile Diaphragm (This is the standard diaphragm. An optional diaphragm may have been installed on the pump. Check original invoice.)	1
12	160-A-1006	Lower Standard	1
13	3/8"-16X1" HHCS	Stainless Hex Head Cap Screws	8
14	5/16"-18X1.25"HHCS	Stainless Hex Head Cap Screws	4
15	161-C-583	Reducer Mounting Adapter Plate	1
16	3/8"-16X2.5" HHCS	Stainless Hex Head Cap Screws	4
17	161-D-75	Pump Frame	1
18	161-C-389	Pump Leg	2
19	1/4"-20X1.5 HHCS	Stainless Hex Head Cap Screws with Washers	4
20	161-A-1299	Motor Guard (Optional part installed only when ordered)	0
21	161-A-164	Axle Hanger	0
22	161-A-166	Wheel	0
23	161-A-143	Pal Nut	0
24	161-A-165	Stainless Axle	0
25	3/8"-16X4" HHCS	Stainless Hex Head Cap Screws with Nuts and Washers	0
26	3/8"-16X3" HHCS	Stainless Hex Head Cap Screws with Nuts and Washers	0
27	161-A-147	Pump Handle	0
28	10-32X1 PHMS	Stainless Pan Head Mach. Screws with Nuts and Washers	8
29	160-B-376B-150	Bronze Discharge Chamber 1.5"	1
30	160-A-1207	Inlet/Discharge Valve Assembly	2
31	160-B-378B	Bronze Side Inlet Pump Base	1
32	160-B-375B	Bronze Suction Chamber 1.5"	1
33	114N-18-200	Compact Spares Kit	

Includes: Qty 1 - 113N-18 DIAPHRAGM (key # 3)

Qty 2 - 160-A-1207 (key #27)

Qty 2 - 160-A-1204 (key # 32)



## Parts List 220GWA-150

P-220GWA-150

<b>Edson Order #</b>	<b>Description</b>
220EWA-10-150	Compact Electric Diaphragm Pump, Cart Mounted, Aluminum, 1.5" MNPT Inlet and 1.5" FNPT Discharge

Key #	Edson Order #	Description	Qty
1	161-A-1385	Gasoline Engine, 3.5 HP	1
1a.	161-B-617	Adapter-Gas Engine to C-Face Mounting Adapter	1
2	161-A-1811-2	Motor Coupling for A-1744 Reducer (included with Reducer key #3)	1
3	161-A-1744	57 to 1 C-Face Gear reducer and coupling (includes Motor Coupling & Eccentric Disk key #s 2 & 4)	1
4	161-A-1697	Eccentric Disk (included with Reducer key # 3)	1
5	161-A-1161	Snap Ring (included with Eccentric Housing key #6)	1
6	161-C-508	Eccentric Housing With Snap Ring (includes Zerk Fitting & Snap Ring key #s 6, 7, 8)	1
7	161-A-150	Zerk Grease Fitting (included with Eccentric Housing key #6)	1
8	161-A-399	Zerk Fitting Dust Cap (included with Eccentric Housing key #6)	1
9	1/4-20X1" HHCS	Stainless Hex Head Cap Screws	2
10	160-A-1204	Sealing Washers	2
11	113N-18	Nitrile Diaphragm (This is the standard diaphragm. An optional diaphragm may have been installed on the pump. Check original invoice.)	1
12	160-A-1006	Lower Standard	1
13	3/8"-16X1" HHCS	Stainless Hex Head Cap Screws	8
14	5/16"-18X1.25"HHCS	Stainless Hex Head Cap Screws	4
15	161-C-583	Reducer Mounting Adapter Plate	1
16	3/8"-16X2.5" HHCS	Stainless Hex Head Cap Screws	0
17	161-D-75	Pump Frame	1
18	161-C-389	Pump Leg	1
19	1/4"-20X1.5 HHCS	Stainless Hex Head Cap Screws with Washers	4
20	161-A-1299	Motor Guard (Optional part installed only when ordered)	0
21	161-A-164	Axle Hanger	2
22	161-A-166	Wheel	2
23	161-A-143	Pal Nut	2
24	161-A-165	Stainless Axle	1
25	3/8"-16X4" HHCS	Stainless Hex Head Cap Screws with Nuts and Washers	2
26	3/8"-16X3" HHCS	Stainless Hex Head Cap Screws with Nuts and Washers	2
27	161-A-147	Pump Handle	1
28	10-32X1 PHMS	Stainless Pan Head Mach. Screws with Nuts and Washers	8
29	160-B-376A-150	Aluminum Discharge Chamber 1.5"	1
30	160-A-1207	Inlet/Discharge Valve Assembly	2
31	160-B-378A	Aluminum Side Inlet Pump Base	1
32	160-B-375A	Aluminum Suction Chamber 1.5"	1
33	114N-18-200	Compact Spares Kit	

Includes: Qty 1 - 113N-18 DIAPHRAGM (key # 3)

Qty 2 - 160-A-1207 (key #27)

Qty 2 - 160-A-1204 (key # 32)



## Parts List 220GWB-150

P-220GWB-150

<b>Edson Order #</b>	<b>Description</b>
220EWB-10-150	Compact Electric Diaphragm Pump, Cart Mounted, Bronze, 1.5" MNPT Inlet and 1.5" FNPT Discharge

Key #	Edson Order #	Description	Qty
1	161-A-1385	Gasoline Engine, 3.5 HP	1
1a.	161-B-617	Adapter-Gas Engine to C-Face Mounting Adapter	1
2	161-A-1811-2	Motor Coupling for A-1744 Reducer (included with Reducer key #3)	1
3	161-A-1744	57 to 1 C-Face Gear reducer and coupling (includes Motor Coupling & Eccentric Disk key #s 2 & 4)	1
4	161-A-1697	Eccentric Disk (included with Reducer key # 3)	1
5	161-A-1161	Snap Ring (included with Eccentric Housing key #6)	1
6	161-C-508	Eccentric Housing With Snap Ring (includes Zerk Fitting & Snap Ring key #s 6, 7, 8)	1
7	161-A-150	Zerk Grease Fitting (included with Eccentric Housing key #6)	1
8	161-A-399	Zerk Fitting Dust Cap (included with Eccentric Housing key #6)	1
9	1/4-20X1" HHCS	Stainless Hex Head Cap Screws	2
10	160-A-1204	Sealing Washers	2
11	113N-18	Nitrile Diaphragm (This is the standard diaphragm. An optional diaphragm may have been installed on the pump. Check original invoice.)	1
12	160-A-1006	Lower Standard	1
13	3/8"-16X1" HHCS	Stainless Hex Head Cap Screws	8
14	5/16"-18X1.25"HHCS	Stainless Hex Head Cap Screws	4
15	161-C-583	Reducer Mounting Adapter Plate	1
16	3/8"-16X2.5" HHCS	Stainless Hex Head Cap Screws	0
17	161-D-75	Pump Frame	1
18	161-C-389	Pump Leg	1
19	1/4"-20X1.5 HHCS	Stainless Hex Head Cap Screws with Washers	4
20	161-A-1299	Motor Guard (Optional part installed only when ordered)	0
21	161-A-164	Axle Hanger	2
22	161-A-166	Wheel	2
23	161-A-143	Pal Nut	2
24	161-A-165	Stainless Axle	1
25	3/8"-16X4" HHCS	Stainless Hex Head Cap Screws with Nuts and Washers	2
26	3/8"-16X3" HHCS	Stainless Hex Head Cap Screws with Nuts and Washers	2
27	161-A-147	Pump Handle	1
28	10-32X1 PHMS	Stainless Pan Head Mach. Screws with Nuts and Washers	8
29	160-B-376B-150	Bronze Discharge Chamber 1.5"	1
30	160-A-1207	Inlet/Discharge Valve Assembly	2
31	160-B-378B	Bronze Side Inlet Pump Base	1
32	160-B-375B	Bronze Suction Chamber 1.5"	1
33	114N-18-200	Compact Spares Kit	

Includes: Qty 1 - 113N-18 DIAPHRAGM (key # 3)

Qty 2 - 160-A-1207 (key #27)

Qty 2 - 160-A-1204 (key # 32)

