



AIR POWERED DIAPHRAGM PUMP MODELS 120A

Installation and Operations Manual

Index:

Page 1	Index
Page 2	Performance & Dimensions
Page 3	Installation Guidelines
Page 6	Operation Guidelines
Page 8	Maintenance & Repair
Page 9	Trouble Shooting
Page 10	Parts

Pump Models

- 120ACA-200 Air Powered Diaphragm Base Mount Aluminum 2" Inlet and 2" Discharge**
- 120ACB-200 Air Powered Diaphragm Base Mount Bronze 2" Inlet and 2" Discharge**

- Make sure the pump received is the pump ordered. Compare the pump with the packing list.
- Make sure the parts list attached to this manual is the one for your pump.
- Fill in the Serial No. and Model No. below

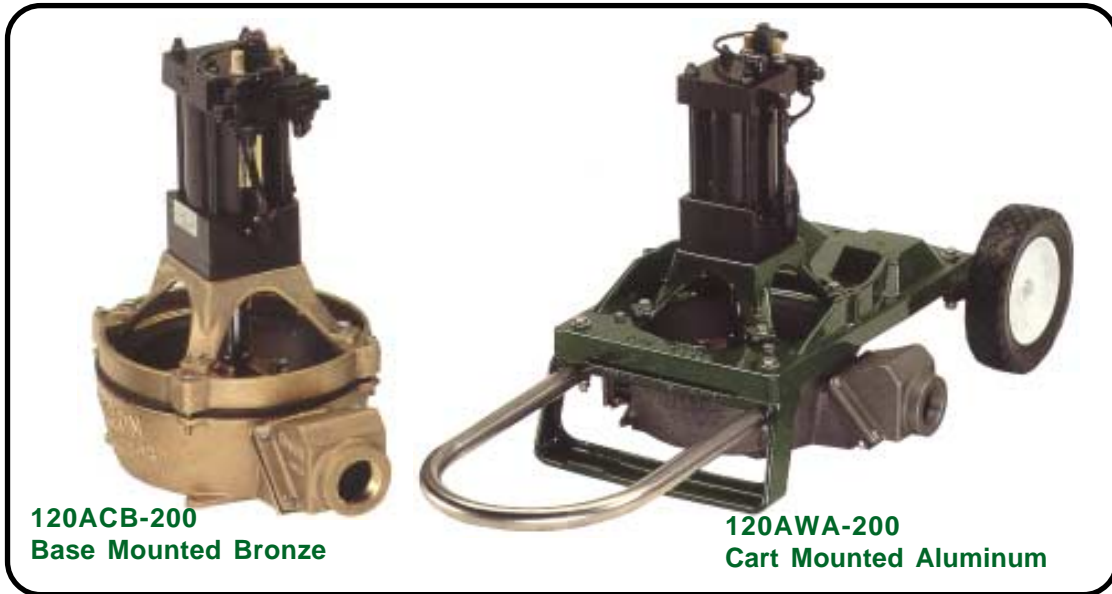

ENTER YOUR PUMP DATA HERE

SYSTEM SERIAL #
From Edson Serial # Sticker On Pump Frame

PUMP MODEL #
From Packing List i.e.. 120ACB-150



Performance & Specifications

Pump Performance Is Dependent On Cycle Rate of The Pump Air Cylinder & The Plumbing Head.

- Volume is expressed in GPM (gallons per minute) and LPM (liters per minute)
- A Cycle Rate is 1 up and down stroke of the cylinder. Maximum cycles rate for this pump should not exceed 60 per minute. Over 60 the pump begins to cavitate.
- Head conditions are determined by the height, length and size of the installation plumbing connected to the inlet and discharge of the pump base.

General Performance Specifications:

- Static Head: Suction 15 ft / 4.57m Discharge 15 ft / 4.57m (2" Hose or Pipe)
- Dry Suction Lift: 12 ft / 3.65m (2" ID Pipe or Hose)
- Continuous Duty Discharge Heads: Should be Limited to 10 ft. / 3m
- Performance: 40 GPM / 151LPM at 5 ft Suction Lift and 0 Discharge at 60 Cycles per Min. w/ 2" Pipe

Volume Charts:

- Use the following charts as guides to determine the performance volume at different cycle rates with the pump installed with a variety of suction and discharge plumbing conditions.

56 Cycles Per Min.	DISCHARGE HEIGHT			
	0	5 ft 1.5 m	10 ft 3 m	
S U C T I O N H E I G H T	1 ft .3 m	38/144	32/121	24/91
	5 ft 1.5 m	30/114	30/114	23/87
	10 ft 3 m	28/106	26/98	16/61
	12 ft 3.7 m	28/106	26/98	14/53

gpm / lpm

40 Cycles Per Min.	DISCHARGE HEIGHT			
	0	5 ft 1.5 m	10 ft 3 m	
S U C T I O N H E I G H T	1 ft .3 m	27/102	23/87	17/64
	5 ft 1.5 m	21/81	21/81	16/62
	10 ft 3 m	20/76	19/70	11/43
	12 ft 3.7 m	20/78	19/70	10/38

gpm / lpm

36 Cycles Per Min.	DISCHARGE HEIGHT			
	0	5 ft 1.5 m	10 ft 3 m	
S U C T I O N H E I G H T	1 ft .3 m	24/92	21/78	15/58
	5 ft 1.5 m	19/73	19/73	15/56
	10 ft 3 m	18/68	17/63	10/39
	12 ft 3.7 m	18/68	17/63	8/30

30 Cycles Per Min.	DISCHARGE HEIGHT			
	0	5 ft 1.5 m	10 ft 3 m	
S U C T I O N H E I G H T	1 ft .3 m	20/77	19/72	17/64
	5 ft 1.5 m	17.5/66	17/64	16/61
	10 ft 3 m	17/64	16/61	15/57
	12 ft 3.7 m	13/49	12/47	10/38

gpm / lpm

20 Cycles Per Min.	DISCHARGE HEIGHT			
	0	5 ft 1.5 m	10 ft 3 m	
S U C T I O N H E I G H T	1 ft .3 m	14/52	11/42	9/34
	5 ft 1.5 m	11/42	11/42	8/31
	10 ft 3 m	10/38	9/34	6/22
	12 ft 3.7 m	10/38	9/34	5/19

gpm / lpm

13 Cycles Per Min.	DISCHARGE HEIGHT			
	0	5 ft 1.5 m	10 ft 3 m	
S U C T I O N H E I G H T	1 ft .3 m	9/34	7/26	5/20
	5 ft 1.5 m	7/26	7/26	5/20
	10 ft 3 m	7/26	6/23	4/14
	12 ft 3.7 m	7/26	6/23	3/12

Dimensions

120CA-200
120CB-200

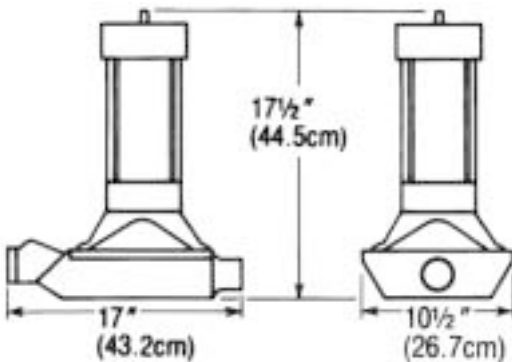

120AWA-200
120AWB-200

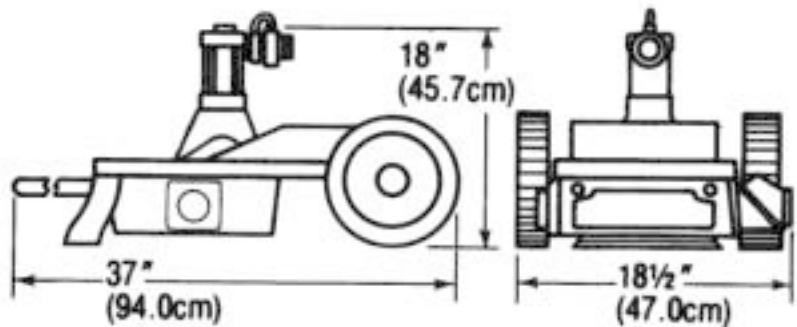

Installation Guidelines

- Step 1 Check All Bolts** - Make sure that all bolts on the pump are tight. Tools: 2ea. 9/16", 1/2" and 7/16" Box Wrenches.
- Step 2 Install Stainless Steel Handle** - (Cart Mounted Pumps Only) Remove spacers & replace with handle.

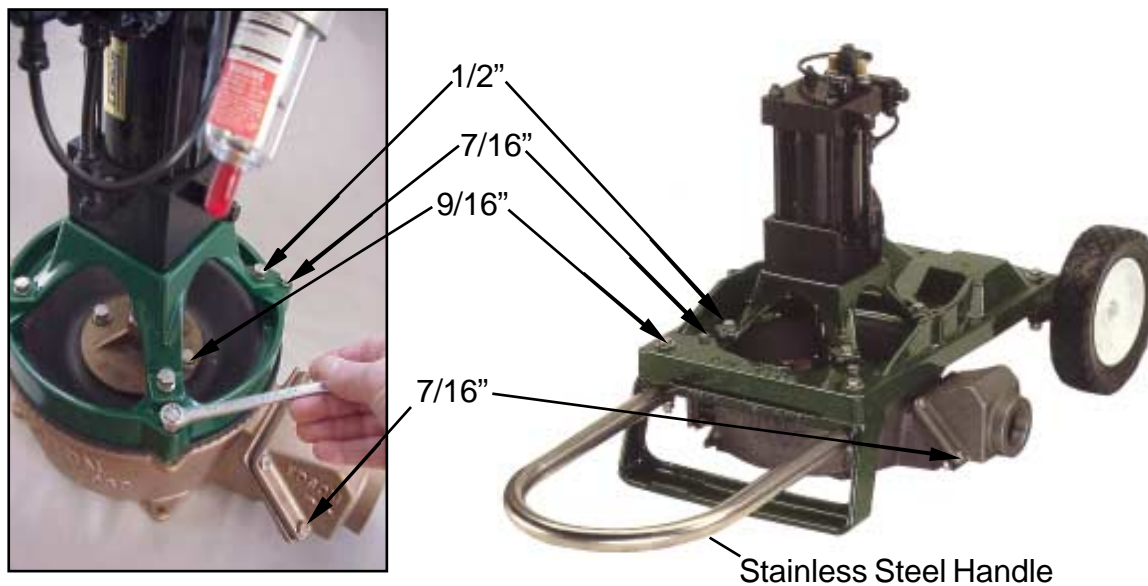

- Step 3 Place Pump** - The pump must be installed so that the flapper valves will open and close. The drawings below show how the pump can and can not be installed in relationship to its' horizontal and vertical axis.

Horizontal Axis

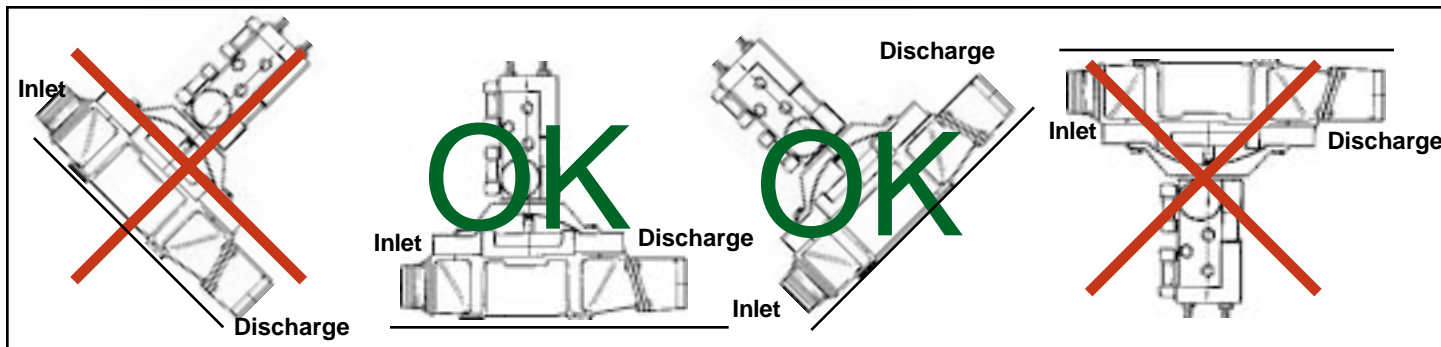

Vertical Axis

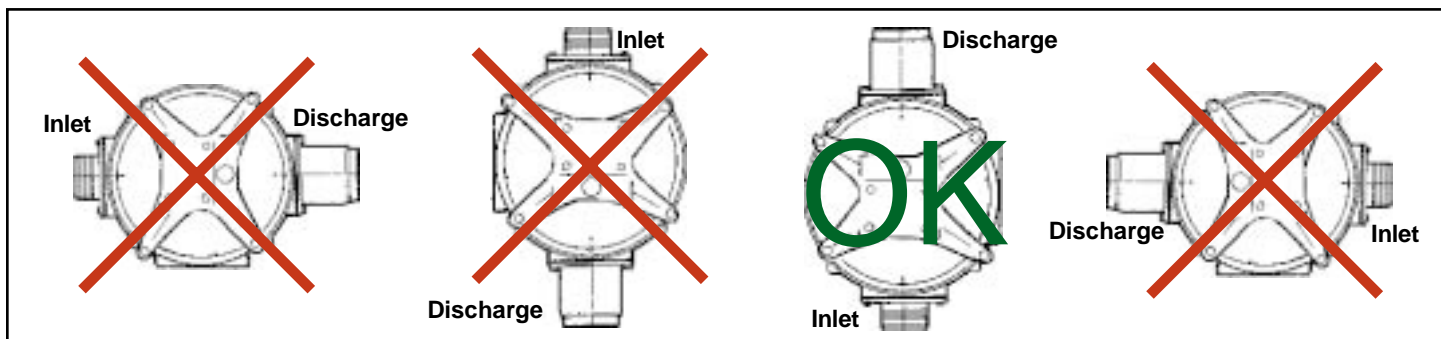

- Step 4** **Connect The Air Line** - Air line should be 1/4" pipe or hose. It should deliver at least 8 ACFM and regulated between 85 and 95 psi. It is connected to the tee on the top of the cylinder. It is recommended that a flow control valve be installed between the regulator and the pump air cylinder. (Regulator and flow control are not included.)
- Step 5** **Run The Pump Air Cylinder** - Adjust air regulator to 90 psi. Open flow control valve all the way. Cylinder should cycle at approximately 60 times per minute.

Important
Air Pumps are factory set to 60 cycles per minute with the input air holding at 85 psi run pressure and no liquid being pumped.

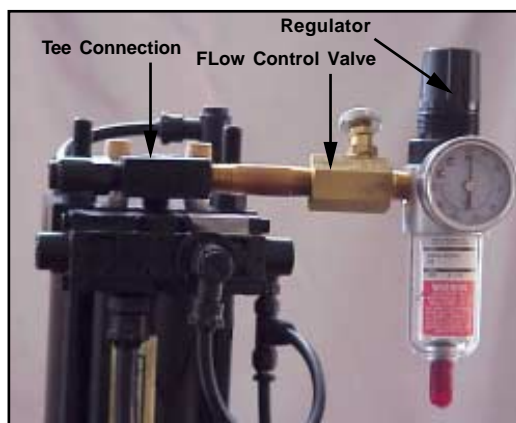

Important
Do not control pump cycle rate by increasing or decreasing air line pressure. Air line pressure should always be kept between 85 and 95 psi.

- Step 6** **Practice Adjusting The Pump Cycle Rate** - There are two ways to control the cycle rate. The first is by adjusting the 2 needle valves, one on each end of the air solenoid. The second is by closing and opening the air flow control valve. You will use a combination of both adjustments to set the pump performance you need once the plumbing is installed and liquid is being pumped.
1. Open the air line.
 2. Set air line pressure to 90 psi.
 3. Open air flow control valve all the way.
 4. Using a very small flat head screwdriver start closing (clockwise) the right hand solenoid needle valve. The down stroke of the air cylinder should start slowing down.
 5. Now close the left hand needle valve. The up stroke of the air cylinder should start to slow
 6. Now reset the cycle rate to 60 cycles per minute by opening each needle valve till you are getting one down stroke per second and you perceive that the timing on the up stroke and the down stroke is approximately the same. Use a watch with a sweep second hand to time the cycle rate.
 7. Now open and close the air flow control valve and note the change in cylinder speed.

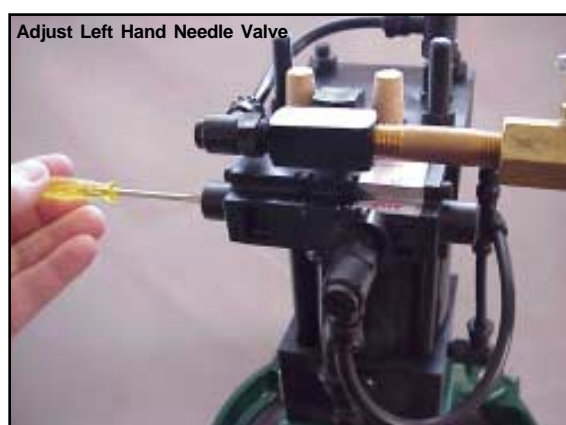

Step 7 Install Plumbing - Good pump performance requires plumbing to be installed properly for this pump.

- **DO NOT INSTALL THE PUMP AND PLUMBING SO AIR WILL BE TRAPPED.**
 BECAUSE trapped air can completely restrict the flow, or at the least require more work from the pump resulting in early diaphragm failure. Install pump and plumbing so any air introduced into the plumbing will not be trapped but flow naturally through liquid and out of the system.

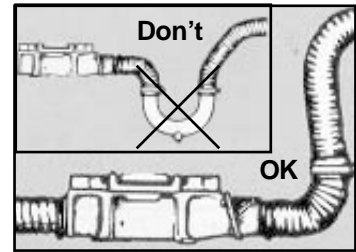

- **SHOULD NOT INSTALL PUMP WITH POSITIVE HEAD ON THE INLET -** Under standard operating guidelines the pump should be above the liquid it is being used to transfer.
 BECAUSE of the flow through check valves, stopping the pump will not stop the liquid from flowing. Under the force of gravity liquid will pass right through a diaphragm pump. Also consider a diaphragm pump can not control a siphon condition. They are used many times to start one.

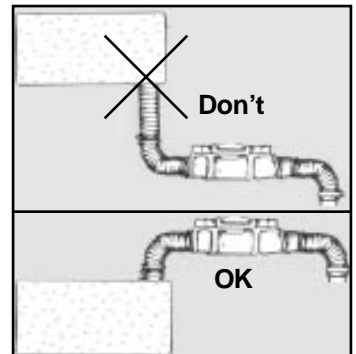

- **DISCHARGE FITTINGS, PIPE AND HOSE SHOULD ALL BE THE SAME SIZE AND NEVER BE SMALLER THAN THE INLET.**
 BECAUSE a smaller discharge line increases work for the pump and increases the possibility of clogging.

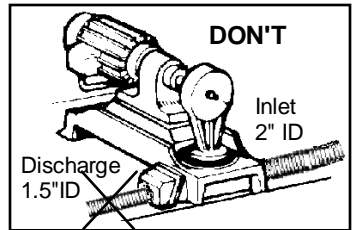

- **USE ONLY LONG RADIUS ELBOWS.**
 BECAUSE a they reduce back pressure and wear on the pump diaphragm. When pumping liquid with solids they help prevent clogs in the plumbing.

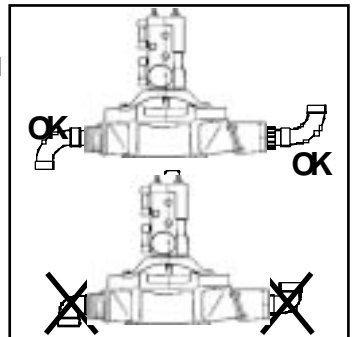

- **INSURE ALL HOSE AND FITTINGS ARE AIR TIGHT.**
 Because self priming performance depends on air tight suction line. It prevents leaks

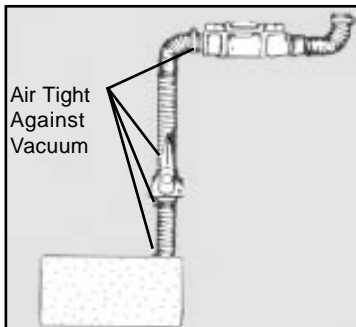

Running The Pump Dry:

This Pump will run dry indefinitely without damage.

Pumping Liquids with Suspended Solids:

- **KEEP SOLIDS IN SUSPENSION** - When the pump is used to pump solid matter such as sludge at the bottom of a tank, or to dredge out a section of a lagoon make, sure the solids have enough liquid mixed in to allow it to flow. Raking or stirring while the pump is pumping will keep solids in suspension. Rule of thumb in pumping viscous liquids or combinations of liquids with solids, "If It Will Not Flow Through A Line Under Gravity, The Pump Will Most Likely Not Pump It."
- **FLAPPER CHECK VALVES AND SOLIDS** - Solids trapped under the check valves will prevent self priming. This is likely to occur when the pump is used in sewage or sump pump out applications . Flushing with water will generally clear out the solid matter. Installing secondary clear flapper check valves right at the inlet and discharge will improve the dry suction start performance of the pump and make clearing the valves easy. Order Edson Clear Check Valves 69CL-150 (1.5").
- **PUMPING AT THE PROPER SPEED** - When pumping liquid with solids the speed may be too slow to keep the solids and the liquid combined. The solids will stop moving and begin to clog the line. Pumping at a faster rate or decreasing the hose size to increase velocity may be the solution. Check With Edson Customer Service.
- **USING A STRAINER ON THE INLET** - If the solids are too large they will block the inlet or get stuck in the suction line. The end a suction hose can become attached to a flat surface cutting off all flow. Using an Edson strainer will prevent these conditions. Order an Edson Shatterproof Bronze Strainer 111BR - 150
- **USING A DISCHARGE LOOP** - For sewage and sump applications when the discharge drains naturally down and away from the pump, installing an 8" to 10" positive loop right on the discharge port will improve the self priming feature. When you stop pumping the loop traps some liquid against the discharge valve improving the seal.

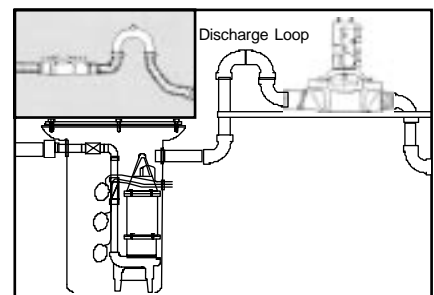
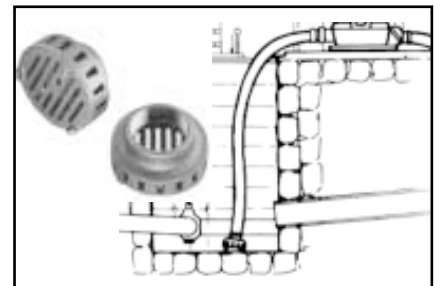
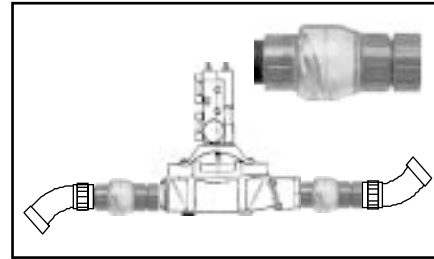
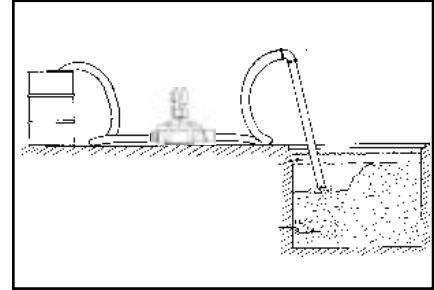

How The Pump Works

- The air cylinder raises and lowers the diaphragm.
- Raising the diaphragm creating a vacuum.
- The vacuum forces the discharge valve assembly closed.
- Atmospheric pressure pushes liquid and/or air up the inlet plumbing to fill the vacuum.
- When the diaphragm is driven down the air and liquid under the diaphragm is compressed closing the inlet check valve and forcing the liquid and /or air out the discharge.
- The closing of the inlet valve assembly also prevents the liquid and air trapped in the inlet line from dropping back down (to atmosphere).

Suction Stroke

Inlet Valve Assembly:
opens into the pump

Discharge Valve Assembly:
closes and seals on the valve
seat that is part of the pump
base under the discharge
chamber.

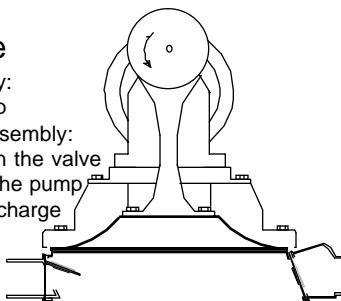

Discharge Stroke

Discharge Valve Assembly:
opens away from the pump

Inlet Valve Assembly:
closes and seals on the valve
seat that is part of the inlet
chamber.

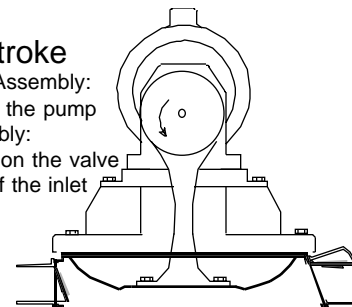

Pump Performance Tests:

● Volume Test - Tests overall performance of the pump installation.

1. Use a container with a known capacity of at least 2 gallons.
2. Empty the container using the suction side of the pump or fill it from the discharge. When using the fill test make sure the pump is fully primed before filling the container.
3. Use a watch to record the time it takes. Repeat the test at least twice.
4. Establish GPM rate. Example 1: It took 10 seconds to fill a 5 gallon container. The GPM rate is 30 Gallons Per Minute. (60 seconds divided by 10 seconds times 5 gal.) Example 2: It took 10 seconds to empty a 2 gallon container. The GPM rate is 12 Gallons Per Minute. (60 seconds divided by 10 seconds times 2 gal.)
5. Record the cycle speed of the pump. Know the head conditions of your test and compare the results of your test with the volume of the appropriate Volume Chart on page 2. Every installation is different so use the charts as a guideline.
6. Example 1: The "fill test" at 30 GPM. The diaphragm is going up and down at 56 cycles per minute. The pump is approximately 6 ft. above the liquid. I disconnected the installation discharge line and replaced it with a 3 ft. length of 2" hose so I could do the fill test. Using the 56 cycle per minute Volume Chart from page 2, I know that at a suction height of 5 ft. and a discharge height of between 0 and 5 ft. I should get approximately 30 GPM. The installation is performing within the guidelines.
6. Example 2: The "empty test" at 12 GPM. The diaphragm is going up and down at 30 cycles per minute. The pump was approximately 5 ft. above the 2 gal. container and the discharge line goes up 4 ft. From the 30 cycle per minute Volume Chart on page 2, I know that with a suction height of 5 ft. and a discharge height of 0 to 5 ft. I should get approximately 17 GPM. The installation is performing below the guidelines. See the Trouble Shooting section of this manual.

● Vacuum Gauge Test - Tests the performance of the discharge valve and valve seat.

1. Attach a 5' length of non-collapsing hose or pipe with a vacuum gauge installed to the inlet of the pump. Make sure the line is completely sealed and air tight.
2. Turn on the pump and let it run till the gauge stabilizes. Record the reading.
3. Turn off the pump and watch the gauge.
4. If the discharge is working properly the gauge should build and hold at 10" to 12"hg. Do not be concerned if the vacuum pressure slowly returns to 0 within a minute or so.
5. If you do not get any vacuum reading or if the gauge does not get to 10" hg and drops off to 0 as soon as the pump stops, do the same thing again. Listen for air being sucked in around the diaphragm. If you hear air movement, inspect for loose bolts or worn diaphragm. If you hear no air movement, remove the discharge chamber and inspect the valve assembly and valve seat. Clean or replace the valve and clean or resurface the valve seat as appropriate. See Maintenance/Valve Assemblies

- **Pressure Gauge Test - Tests the performance of the suction valve and valve seat.**

1. Attach a 5' length of non-collapsing hose or pipe with a 0 to 15 psi gauge installed to the outlet of the pump. Make sure the line is completely sealed and air tight.
2. Turn on the pump and let it run till the gauge stabilizes. Record the reading.
3. If the suction valve is working properly the gage should build and pulse at 6 to 7 psi. and when the pump is stopped the pressure may hold or slowly returns to 0.
4. If you do not get any pressure reading or if the gauge does not get to 4 psi and drops off to 0 as soon as the pump stops, clean or replace the suction valve and clean or resurface the valve seat as appropriate. See Maintenance/Valve Assemblies

- **Manual Test - Testing the pump valves and valve seats without the use of a gauge.**

1. Remove all fittings from the inlet and discharge of the pump.
2. Turn on the pump.
3. Put your hand over the inlet. If the discharge valve is working properly, you should feel a very strong pulsing suction. The pulsing coincides with the raising and lowering of the diaphragm. If you do not feel any suction, do the same thing again and listen for air being sucked in around the diaphragm. If you hear air movement, inspect for loose bolts or worn diaphragm. If you hear no air movement, remove the discharge chamber and inspect the valve assembly and valve seat. Clean or replace the valve and clean or resurface the valve seat as appropriate.
4. Press your hand over the discharge. If the inlet valve is sealing properly, the pressure of the pump down stroke should push your hand away. If it does not and the air is forced out the inlet remove the inlet chamber and inspect the valve assembly and valve seat. Clean or replace the valve and clean or resurface the valve seat as appropriate. See Maintenance/Valve Assemblies

Maintenance

Diaphragm and check Valves: Over time these parts wear and need to be replacement. The ability to easily and quickly replace these inexpensive parts is one of the major advantages of an Edson diaphragm pumps. Edson has packaged these parts as Spares Kits. See the parts list for the order #s.

- Change the diaphragm as required.
- Inspection and testing on a regular basis is recommended. For continuous duty application, inspect the pump daily until a life pattern is established.
- Look for leaks, cracks or splits on the surface of the diaphragm.
- Life expectancy is directly related to head conditions, run time and diaphragm material. The higher the suction and discharge pressures the shorter the life.



Valve Assemblies & The Valve Seats: The sealing of the flapper valves are what makes the diaphragm pump work. If the valves are not sealing properly, the pump will not be performing to full potential or may not be pumping at all. The valves tend to last longer than the diaphragm. When you change the diaphragm inspect the valves for cracks and delamination and the valve seats for pitting and any build up that will prevent the valve rubber from sealing effectively. Testing the pump is the best way to evaluate performance.

- Change the valve assemblies as required.
- Inspection and testing on a regular bases is recommended. For continuous duty application, inspect the pump daily until a life pattern is established.
- See Pump Performance Tests .



Trouble Shooting

The Edson Air Powered Diaphragm Pump is very simple and problems are usually isolated to the following components:

- **Suction and Discharge Plumbing**
- **The Diaphragm and Valves**
- **The Air Cylinder**

1.Problem	Possible Causes	Action
<p>Pump is running, liquid is not moving.</p>	<p>a. Suction line is blocked. b. Suction line has air leak between liquid and inlet of the pump. c. Discharge and/or suction valves are not working. d. Diaphragm has a leak. e. Discharge or suction line is to high.</p>	<p>If the cause is not obvious, isolate the source. Disconnect the inlet and discharge plumbing from the pump and perform the Manual Test. If the cause is not in the pump check for a block or an air leak in the suction line. Suction air leaks can be cumulative and can be as simple as one or two fittings not being sealed properly. Review Plumbing</p>
<p>2.Problem Air Cylinder is not going up and down.</p>	<p>Possible Causes a. Air pressure is low. b. Discharge or suction line is blocked. c. Air cylinder is malfunctioning.</p>	<p>Action If the cause is not obvious, isolate the source. Check air line for pressue and flow. If ok, disconnect the inlet and discharge plumbing from the pump and restart the pump. If pump cycles without the plumbing connected, there could be a clog in the lines. The back pressure caused by a complete blockage in the inlet and discharge line will stop the pump. If the pump cylinder still does not cycle then the problem is in the air cylinder. See air cylinder section.</p>

3.Problem
 Diaphragm is wearing out much earlier than expected.

- Possible Causes**
- Liquid being pumped is not compatible with the diaphragm material.
 - Discharge and/or suction back pressure too high.

Action
 Consult a chemical resistance chart. If material being pumped is compatible with the diaphragm being used, review the pump performance specifications and installation guidelines in respect to the installation. Diaphragm life will be reduced with the increase in discharge and suction head. Expected diaphragm life is different based on the material and style of the diaphragm used. Call Edson Customer Service for details.

4.Problem
 Pump base and/or lines keep filling with solids

- Possible Causes**
- Line velocity is too slow to keep the solids in suspension.
 - The percent of solids is too high.

Action
 Speeding up the pump will help increase the velocity. Using a strainer can reduce the size and percent of solids. Diluting the slurry by increasing the amount of liquid or by increasing the agitation of the mix may solve the problem.

Parts 120ACB-200

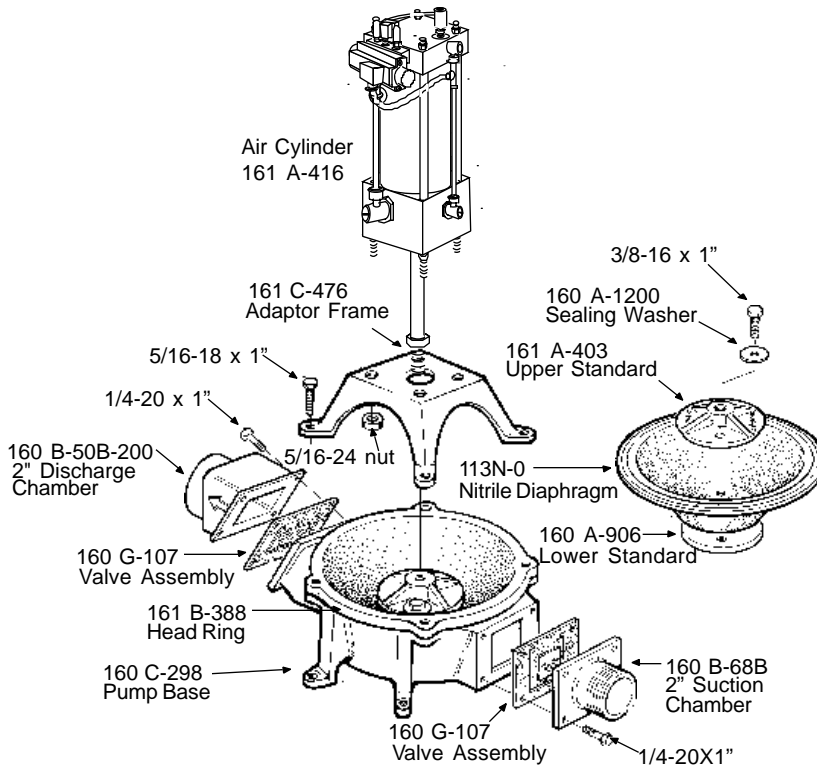

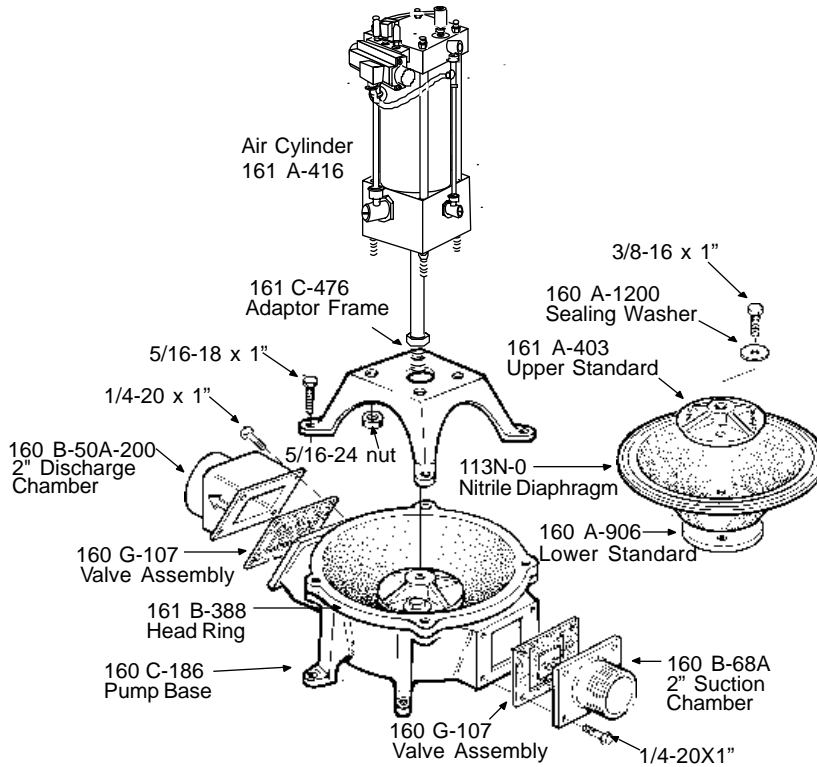

Parts 120AWB-200

- 161-A-166 Wheel(2)
- 161-A-164 Axle Hanger(2)
- 161-A-165 SS Axle
- 161-A-143 Pal Nut(2)

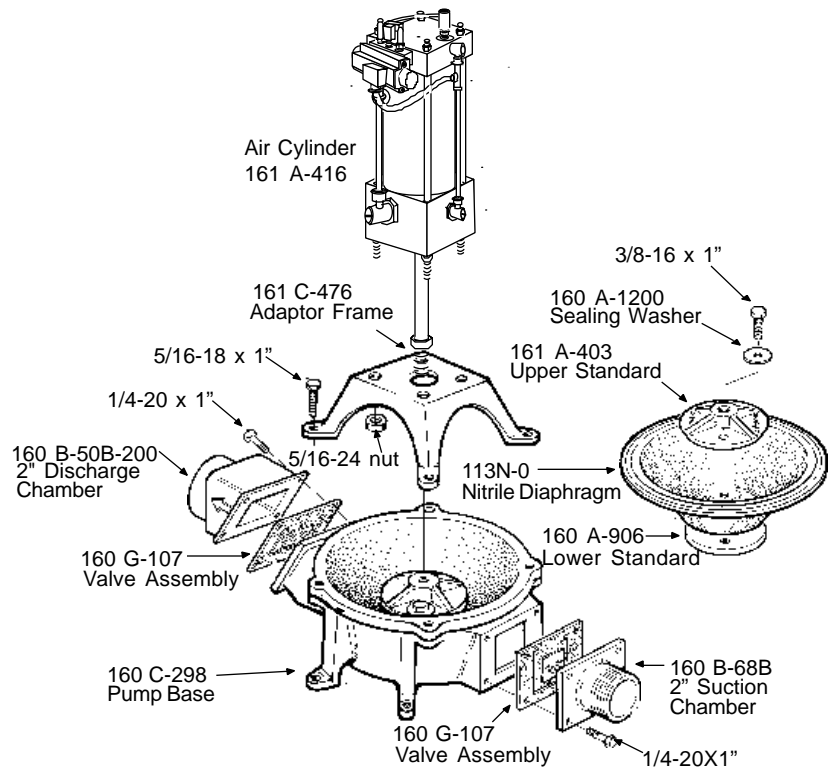
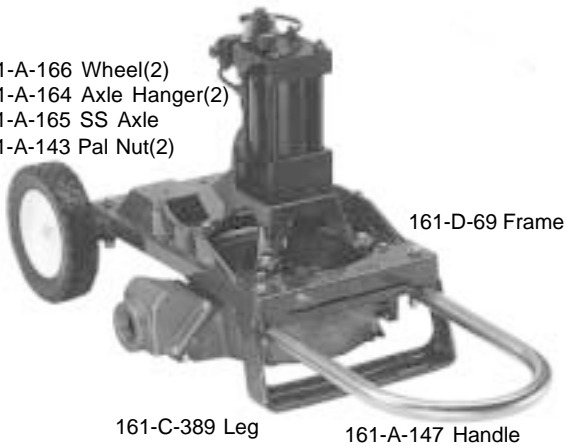

Parts 120AWA-200

- 161-A-166 Wheel(2)
- 161-A-164 Axle Hanger(2)
- 161-A-165 SS Axle
- 161-A-143 Pal Nut(2)

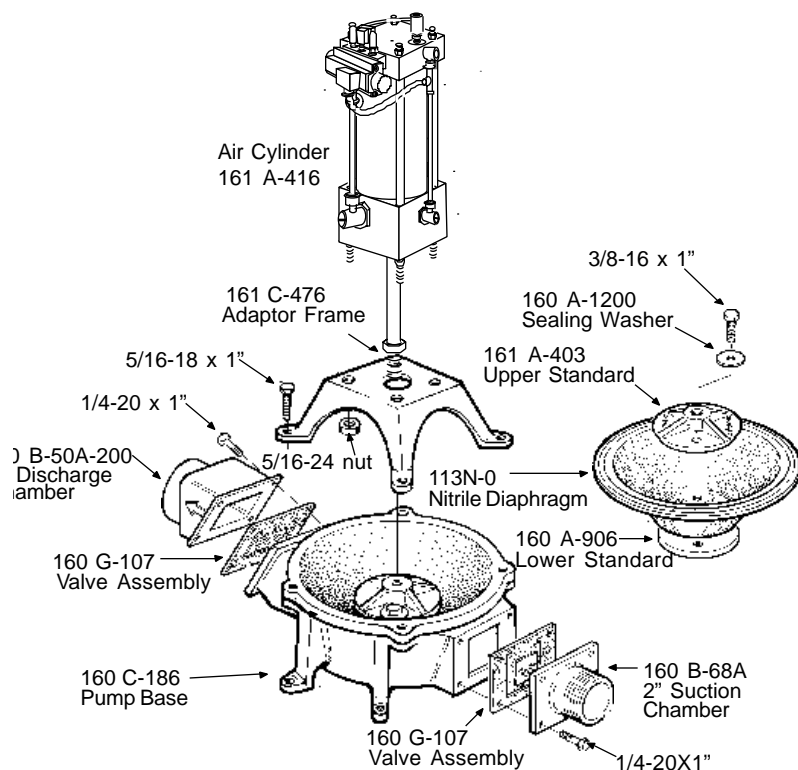
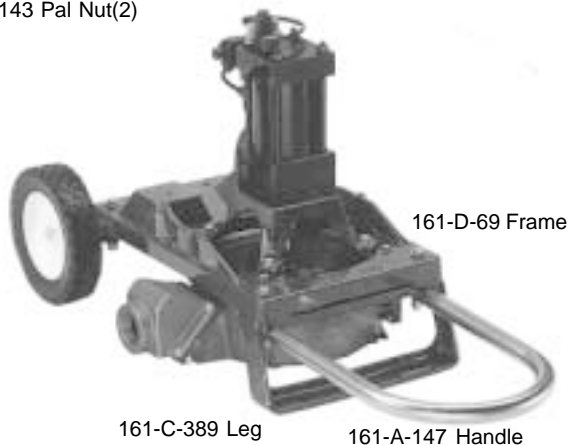

Parts: Spares Kits

- Nitrile
 Order No. 114N 117-120
 1 Diaphragm 113N - 0
 2 Valve Assemblies 160 G-107
 2 Sealing Washers 160 A-1200

- Hypalon
 Order No. 114H 117-120
 1 Diaphragm 113H - 0
 2 Valve Assemblies 160 G-107H
 2 Sealing Washers 160 A-1200

- Viton
 Order No. 114V 117-120
 1 Diaphragm 113V - 0
 2 Valve Assemblies 160 G-107V
 2 Sealing Washers 160 A-1200

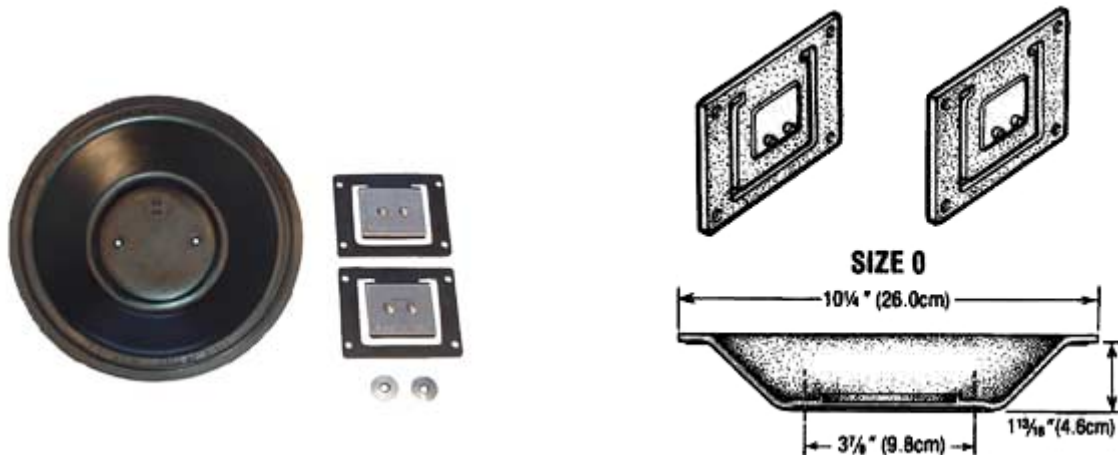

Parts: Spares Kits



Air Cylinder Part Kits:
 RPK-121 Rebuild Kit for 120A (Includes * Parts)
 RPK-129 Spring & Poppet Kit,A-416 Air Cylinder
 Air Cylinder Timing Valve for 120A

Order No.s
 161 A-1593
 161 A-1853
 161 A-1472

	33	1	A-155	PISTON SPACER	STEEL
	32	1	86 X 15B	HEX ADAPTOR	BRASS
	31	2	3 x 1	SOCKET HEAD #10-32 CAP SCREWS	STEEL
	30	2	29 x 4	FLAT HEAD #10-32 PLATE SCREWS	STEEL
	29	1	B-004-ED	CLOSED HEAD W/ POPPET POS. #2	STEEL
	28	1	40 x 3	1/8" PIPE PLUG	STEEL
*	27	2	1M 595	POPPET SPRING	ST.ST
	26	1	1M 594	POPPET BUSHING	BRASS
*	25	2	88 x 006	BUSHING & POPPET "O" RING	BUNA-N
*	24	2	1M 593	POPPET STEM	ST.ST.
	23			3/8" PLASTIC TUBING	POLY
	22			1/4" PLASTIC TUBING	POLY
	21	1	85-111-204	MALE RUN "T"	BRASS
	20	1	85-156-012	STRAIGHT CONNECTOR 3/8"	BRASS
	19	1	152 X 1	1/8" THREAD SEAL	ST/TEFLON
	18	3	85-133-109	1/4" ELBOWS	BRASS
	17	1	3750X4	STREET "T"	BRASS
	16	1	8402100M	ASCO SLIDE VALVE ASSMBLY	
*	15	1	88 x 012	VALVE "O" RING	BUNA-N
	14	1	42 x 10	PISTON LOCKNUT	STEEL
*	13	1	A-059/056	PISTON WICKS	COT./POL.
*	12	2	163 x 32	PISTON SEALS	BUNA-N
*	11	2	88 x 018	PISTON "O" RING	BUNA-N
	10	1	A-155	SPACER	STEEL
	9	1	A-106	CYLINDER TUBE	BRASS
	8	2	85-133-130	1/8" PLASTIC TUBING ELBOW	BRASS
	7	1	B-003	OPENED HEAD WITH POPPET (POS.#2)	C11L17
	6	4	42 x 1	TIE ROD NUTS	STEEL
*	5	1	163 x 27	PISTON ROD SEAL	BUNA-N
	4	1	B-002-E	FRONT FLANGE	C11L17
*	3	1	A-010-GL	BRNG. ASS'LY. (HOUSING;BEARING,"O"RING;SCRAPER)	
	2	4	A-100-1	TIE RODS	C1141
	1	1	B-029	PISTON ROD W/ 3/4-10 THRD'S.	C1141
	ITEM	QTY	NUMBER	DESCRIPTION	MATERIAL
	PARTS LIST				

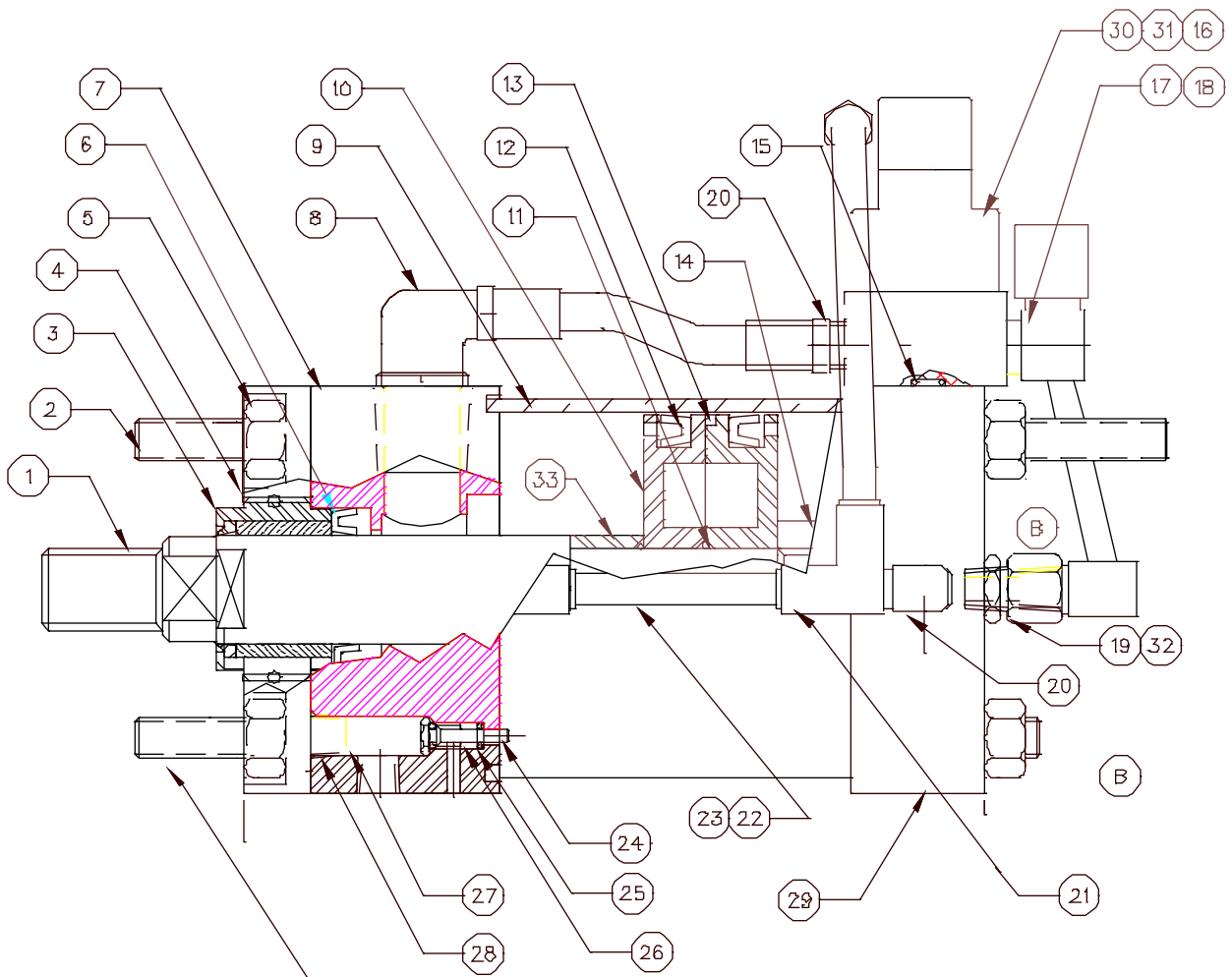
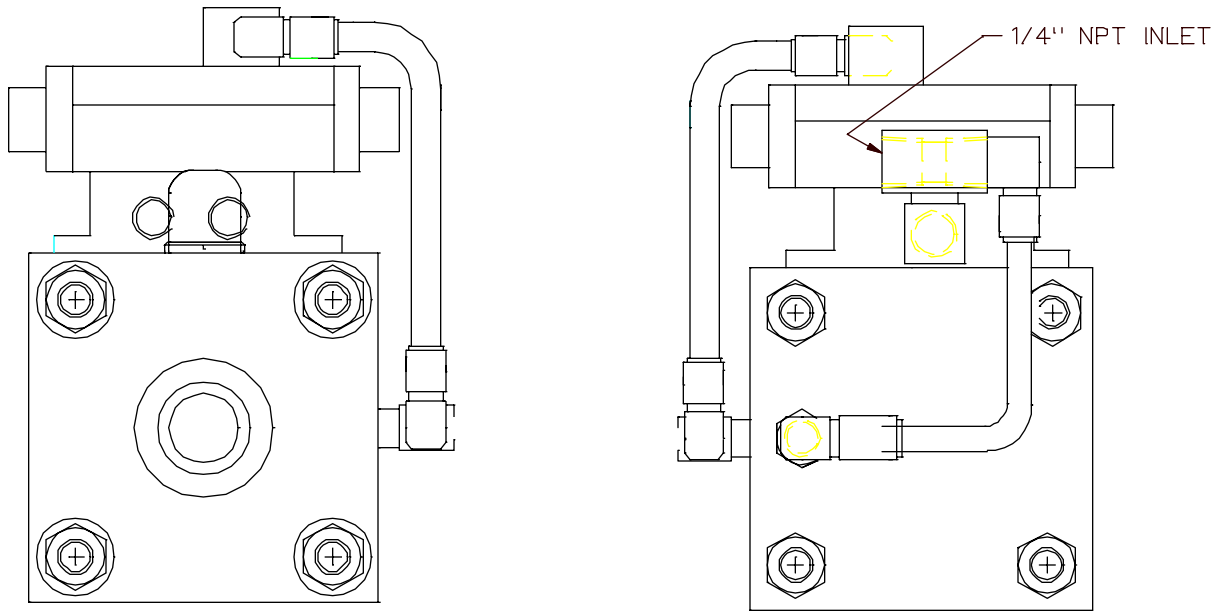

{4} .375-24 TIE ROD THD'S.