

DEMING®

INSTALLATION, OPERATION & MAINTENANCE MANUAL Vertical Sump & Industrial Pumps

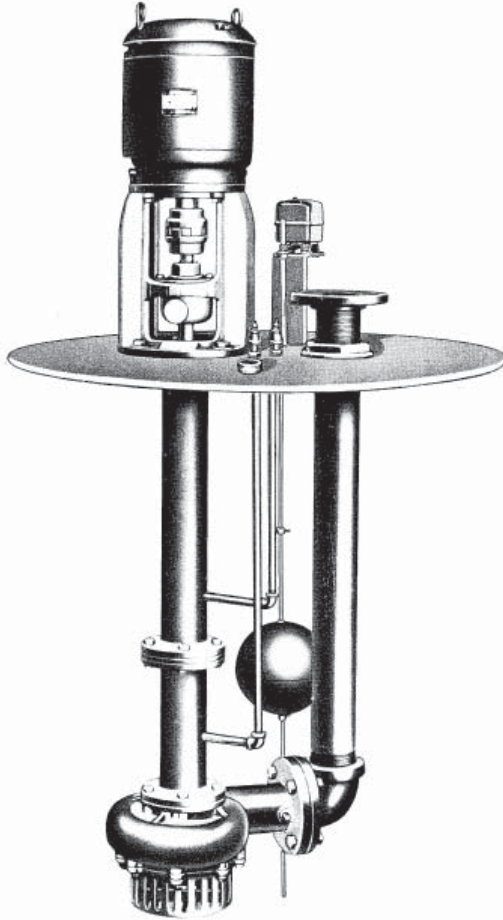

Series: 4560

IMPORTANT!

***Read all instructions in this manual before operating pump.
As a result of Crane Pumps & Systems, Inc., constant product improvement program,
product changes may occur. As such Crane Pumps & Systems reserves the right to
change product without prior written notification.***

CRANE[®]

A Crane Co. Company

PUMPS & SYSTEMS

420 Third Street
Piqua, Ohio 45356
Phone: (937) 778-8947
Fax: (937) 773-7157
www.cranepumps.com

83 West Drive, Bramton
Ontario, Canada L6T 2J6
Phone: (905) 457-6223
Fax: (905) 457-2650

Form No. 120015-Rev. E

CONTENTS

SAFETY FIRST	3
A. GENERAL INFORMATION.....	4
Receiving, Storage, Service Centers	
B. INSTALLATION	4 - 5
C. LUBRICATION.....	5
GENERAL REPAIRS	
D. FOR INSPECTION AND REPAIR OF LIQUID END.....	5
E. FOR INSPECTION AND REPLACEMENT OF BEARING BUSHINGS.....	5
F. TO REMOVE TOP COLUMN ADAPTER	5 - 6
G. REPLACING TOP COLUMN ADAPTER	6
H. INSTALLING NEW BEARING BUSHINGS	6
I. REASSEMBLY OF COLUMN PIPE.....	6
J. ASSEMBLY OF LIQUID END.....	6
K. TO INSPECT OR REPLACE THRUST BEARING AND SEAL.....	6 - 7
L. COLUMN PIPE DOWEL AND SHAFT GUIDE BEARING ASSEMBLY	7 - 8
M. LOCATING TROUBLE	8
N. Fig. 4560 - 4570	8
CROSS-SECTION & PARTS LIST.....	9 - 10
WARRANTY & RETURNED GOODS	11

SAFETY FIRST!

Please Read This Before Installing Or Operating Pump. This information is provided for **SAFETY** and to **PREVENT EQUIPMENT PROBLEMS**. To help recognize this information, observe the following symbols:



IMPORTANT! Warns about hazards that can result in personal injury or indicates factors concerned with assembly, installation, operation, or maintenance which could result in damage to the machine or equipment if ignored.

CAUTION! Warns about hazards that **can or will cause minor** personal injury or property damage if ignored. Used with symbols below.

WARNING! Warns about hazards that can or will cause serious personal injury, death, or major property damage if ignored. Used with symbols below.



Hazardous fluids can cause fire or explosions, burns or death could result.



Extremely hot - Severe burns can occur on contact.



Biohazard can cause serious personal injury.



Hazardous fluids can cause hazardous pressure, eruptions or explosions could cause personal injury or property damage.



Rotating machinery Amputation or severe laceration can result.



Hazardous voltage can shock, burn or cause death.

Only qualified personnel should install, operate and repair pump. Any wiring of pumps should be performed by a qualified electrician.

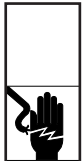

WARNING! To reduce risk of electrical shock, pumps and control panels must be properly grounded in accordance with the National Electric Code (NEC) or the Canadian Electrical Code (CEC) and all applicable state, province, local codes and ordinances. Improper grounding voids warranty.



WARNING! To reduce risk of electrical shock, always disconnect the pump from the power source before handling or servicing. Lock out power and tag.



WARNING! Operation against a closed discharge valve will cause premature bearing and seal failure on any pump, and on end suction and self priming pump the heat build may cause the generation of steam with resulting dangerous pressures. It is recommended that a high case temperature switch or pressure relief valve be installed on the pump body.



CAUTION! Never operate a pump with a plug-in type power cord without a ground fault circuit interrupter.



CAUTION! Pumps build up heat and pressure during operation-allow time for pumps to cool before handling or servicing.



WARNING! Do not pump hazardous materials (flammable, caustic, etc.) unless the pump is specifically designed and designated to handle them.



CAUTION! Do not block or restrict discharge hose, as discharge hose may whip under pressure.



WARNING! Do not wear loose clothing that may become entangled in moving parts.



WARNING! Keep clear of suction and discharge openings. **DO NOT** insert fingers in pump with power connected.



Make sure lifting handles are securely fastened each time before lifting. **DO NOT** operate pump without safety devices in place. Always replace safety devices that have been removed during service or repair. Secure the pump in its operating position so it can not tip over, fall or slide.



DO NOT exceed manufacturers recommendation for maximum performance, as this could cause the motor to overheat.



DO NOT remove cord and strain relief. **DO NOT** connect conduit to pump.



WARNING! Cable should be protected at all times to avoid punctures, cut, bruises and abrasions. Inspect frequently. Never handle connected power cords with wet hands.



WARNING! To reduce risk of electrical shock, all wiring and junction connections should be made per the NEC or CEC and applicable state or province and local codes. Requirements may vary depending on usage and location.



WARNING! Submersible Pumps are not approved for use in swimming pools, recreational water installations decorative fountains or any installation where human contact with the pumped fluid is common.



WARNING! Products returned must be cleaned, sanitized, or decontaminated as necessary prior to shipment, to insure that employees will not be exposed to health hazards in handling said material. All Applicable Laws And Regulations Shall Apply.



Bronze/brass and bronze/brass fitted pumps may contain lead levels higher than considered safe for potable water systems. Lead is known to cause cancer and birth defects or other reproductive harm. Various government agencies have determined that leaded copper alloys should not be used in potable water applications. For non-leaded copper alloy materials of construction, please contact factory.



Crane Pumps & Systems, Inc. is not responsible for losses, injury, or death resulting from a failure to observe these safety precautions, misuse or abuse of pumps or equipment.

A - GENERAL INFORMATION

TO THE PURCHASER:

Congratulations! You are the owner of one of the finest pumps on the market today. These pumps are products engineered and manufactured of high quality components. With years of pump building experience along with a continuing quality assurance program combine to produce a pump which will stand up to the toughest applications.

Check local codes and requirements before installation. Servicing should be performed by knowledgeable pump service contractors or authorized service stations.

This pump is designed for pumping raw or treated sewage, light sludge, slurries, industrial wastes and similar liquids containing solids. Standard pumps are assembled, adjusted and lubricated at the factory before shipment. Motor and flexible shaft coupling are normally shipped unmounted and are to be installed on the pump at job site.

RECEIVING:

Upon receiving the pump, it should be inspected for damage or shortages. If damage has occurred, file a claim immediately with the company that delivered the pump. If the manual is removed from the crating, do not lose or misplace.

STORAGE:

Short Term - Pumps are manufactured for efficient performance following long inoperative periods in storage. For best results, pumps can be retained in storage, as factory assembled, in a dry atmosphere with constant temperatures for up to six (6) months.

Long Term - Any length of time exceeding six (6) months, but not more than twenty four (24) months. The units should be stored in a temperature controlled area, a roofed over walled enclosure that provides protection from the elements (rain, snow, wind blown dust, etc.), and whose temperature can be maintained between +40 deg. F and +120 deg. F. Pump should be stored in its original shipping container and before initial start up, rotate impeller by hand to assure seal and impeller rotate freely.

SERVICE CENTERS:

For the location of the nearest Deming Service Center, check your Deming representative or Crane Pumps & Systems Service Department in Piqua, Ohio, telephone (937) 778-8947 or Crane Pumps & Systems Canada, Inc., Bramton, Ontario, (905) 457-6223.

B - INSTALLATION

Standard pumps are completely assembled, carefully adjusted and lubricated at the factory before shipment.

1. a.) The float (532) and rod (529) must be assembled and partially adjusted before installing the pump. Insert the float rod (529) through the guide on the support plate and slide a locking collar (530) on the bottom of the rod, then the float (532) and another locking collar (530).

b.) Slide a locking collar onto the top end of the rod and push rod through float switch arm. Guide the bottom end of the rod through the bottom guide bracket (527) on the pump casing (1) and lock a collar on the end of the rod by tightening the collar set screw.

c.) Lock the collar on the rod below the float about 4" above the bottom guide bracket, then lock the collar above the float at the desired starting (or stopping) level in the sump.

d.) After setting the pump in the pit, push the float switch arm down to its lowest position. Lift the float rod about 1/2" and fasten the top collar on rod with collar resting on switch arm. Lock the last collar 1/2" below the switch arm.

NOTE: See float assembly on page 9.

2. Carefully lower the assembled unit into the pit. The support plate (23) should be approximately level and must rest evenly at all points before it is bolted to the support floor.
3. Turn pump shaft by hand to make sure that it rotates freely after installation - but before turning on the power. If there is a bind in the rotation, make 4 checks and possible adjustments as follows:
 - A. Adjust the position of the impeller by loosening the adjusting nut (66). Raise lock washer (69), then tighten adjusting nut to position the shaft and impeller above their lowest position by from 1/3 to 1/2 turn of the adjusting nut.
 - B. If "A" does not correct binding, loosen top lock nuts (294) of both the discharge pipe and the grease pipe (if furnished) by two or three turns. Then gradually tighten discharge pipe top lock nut while checking shaft until the maximum shaft freedom of rotation is attained.
 - C. If "B" does not free shaft, raise the pump out of the pit and lower the bottom lock nuts of the discharge and lubrication pipes. Then reset the pump, bolting it to its foundation and continue to tighten the top lock nut of the discharge pipe up to 1 or 2 turns until freedom of rotation is attained.
 - D. Tighten the lubrication pipe top lock nut to just bear on the pump plate, raise the pump out of the sump, tighten the bottom lock nuts of the discharge and lubrication pipes and reset the pump.
 - E. Recheck the freedom of shaft rotation.
 - F. Disengage motor half coupling (42) from pump half coupling.
4. Eliminate weight or strain of the piping connected to the pump before connecting this piping to the pump. Recheck freedom of rotation (Section 3) after connecting system piping to pump discharge (295). A check valve and gate valve should be installed at the pump discharge to prevent back wash and pump back spin.
5. Be certain to connect power lines to motor leads as shown on motor wiring diagram for the line voltage used. **Wrong wiring may cause motor burn-out.**

6. Be sure starter or float switch overload protection device is proper for the voltage used and the motor horsepower.
7. **Start motor, and test for proper rotation.** The shaft should rotate clockwise when looking down on the motor. (For left hand pumps the shaft should rotate counter-clockwise.) If rotation is wrong, reverse any two line leads to the motor if 3 phase power is used. If single phase is used, consult motor manufacturer or his representative. After correct rotation is obtained, connect the drive coupling. (If the pump shaft should be rotated in the wrong direction, the shaft couplings might unscrew and cause a bent shaft or broken impeller or casing.)
8. Before starting pump close gate valve. Start pump and slowly open gate valve until desired capacity is obtained.
9. Pump should operate smoothly, If pump vibrates, there may be a severe distortion of the pump as a result of excessive installation strains on pump support plate or discharge pipe, or because of damage in shipment.

C - LUBRICATION

1. Pump bearings are properly filled with grease at the factory before shipment. Periods of subsequent lubrication depend somewhat on local conditions, hours of operation, load, speed, temperature, etc. As a guide we recommend that the thrust bearing (18) be greased every two or three months and, for grease lubricated pumps, the shaft bearing bushings (39) every eight hours of operation. If liquid being pumped contains abrasives, lubricate shaft bearings (39) every four to six hours of operation.
2. A lithium base grease #2 or #3 consistency should be used for thrust bearing (18) and a water resistant grease such as "Lubri-plate 142" for the shaft bearing bushings (39).
3. Motor bearings normally require a lithium base grease #2 or #3 consistency. Follow motor manufacturer's recommendation as to grease and frequency of lubrication.

GENERAL REPAIRS

D - FOR INSPECTION AND REPAIR OF LIQUID END

1. Close discharge gate valve and disconnect pipe at pump support plate, also remove electric wires from the motor. Unscrew foundation bolts in the support plate (23) then lift pump and support plate as a unit from the pit to the floor.

2. Unscrew the top pipe nut (294) and loosen the bottom pipe nut (294). The discharge pipe (161) can now be removed from the pump either by unscrewing the pipe or removing bolts and nuts at the pipe flange.
3. Next, unscrew the nuts (361) holding the strainer (316) to the pump casing (1). (Note: Pump sizes 3MD, 4MD, 5MD, 5MSD and 6MD have two-piece strainers.) Remove nuts (226). Casing can now be removed from casing adapter (71). Place casing gasket (73) in a bucket of water to keep it pliable.
4. Unscrew the impeller nut (26) by turning it counter-clockwise while holding the drive coupling (42) with a strap wrench.
5. Remove the impeller (2) from the shaft (6), use a pry between impeller shroud and casing adapter (71). Remove impeller washer (270). Lift impeller key (32) from shaft.

E - FOR INSPECTION AND REPLACEMENT OF BEARING BUSHINGS

1. Dismantle liquid end as described in Section B.
2. Disconnect grease pipes (335) starting at the pump support plate (23).
3. Unscrew nuts (226) holding the casing adapter (71) and bottom bearing housing (307) to the bottom column pipe (101). The casing and bottom bearing housing can now be removed from the column pipe.
4. If it is necessary to replace the choker ring (257) and bottom bearing bushings (39), carefully note their position in the bearing housing, then, with a piece of tubing or round bar of the proper size, push the bearing bushing and choker ring out of the flanged end of the housing.
5. To remove the intermediate bearing housing (307) and bearing bushings (39), unscrew flange bolts (285) and nuts (256) and slide bottom column pipe (101) off over shaft (6) then slide bearing housing (307) with bearing bushings (39) off the shaft. Note position of bearing bushings in housing then push the bearing bushings out of the housing as described in #4 above.

F - TO REMOVE TOP COLUMN ADAPTER

If pump liquid end and column pipe has been dismantled as described in Section B and C, then proceed as follows:

Unscrew top column bolts (260) and nuts (256) and slide top column pipe (101A) off the shaft, then, top column adapter (199).

Note: If pump motor end has been dismantled as described in Section K, then proceed as follows:

Remove bolts (277) and nuts (258) holding motor support (19) to support plate (23), then, remove bolts (260) and nuts (256). Lift present top column adapter (199) from top column pipe flange and install new adapter in the top pipe flange. Reposition motor support on support plate and replace bolts (260) and nuts (256) and bolts (277) and nuts (258). Complete assembly as described in Section K.

G - REPLACING TOP COLUMN ADAPTER

1. Slide top column adapter (199) over the shaft, then the top column pipe (101A). Line up the holes in the top column pipe flange and top column adapter flange with those in the bottom of the motor support (19) and replace bolts and nuts (260). Tighten securely. Be sure the hole for grease pipe (335) is in proper position.

H - INSTALLING NEW BEARING BUSHINGS

1. Bearing bushings (39) are furnished in sections, two sections required per housing. Place the intermediate bearing housing (308) in a vise, flanged end up. Select a bearing bushing (39) and note that one end shows a grease groove while the other end is plain (except for graphitor and rubber bearings).
2. Position bearing bushing (39) in the cavity of the intermediate bearing housing (307) with grease groove down, and carefully press bearing into position as shown. Also press choker ring (257) into position, (on bottom bearing housing only). Turn the intermediate bearing housing over and carefully press other half of bearing bushing into position in the same manner.



DO NOT COVER GREASE PORT IN SIDE OF BEARING HOUSING.

Note: Other design construction will require same modification of above depending upon the particular construction.

I - REASSEMBLY OF COLUMN PIPE

1. Slide the intermediate bearing housing (307) over the shaft and push against flange of the top column pipe (101A). Turn bearing housing so that grease port in housing lines up with hole in column pipe. Place bolts (285) through holes in flange.
2. Slide bottom column pipe (101) onto shaft with grease hole in line with hole in the top column pipe. Replace nuts (256) and tighten securely. Be sure the hole for grease pipe is in proper position.

3. Next, place bottom bearing housing (307) over the end of the shaft and slide against flange of bottom column pipe (101). Align bolt holes with those of bottom pipe flange, also grease pipe hole.

J - ASSEMBLY OF LIQUID END

1. Position casing adapter (71) against bottom bearing housing flange with discharge in proper position and replace nuts (226). Tighten securely.
2. Replace key (32) in shaft and place impeller (2) on the shaft with keyway over the key. Place a wood block over impeller vanes and tap on wood to seat impeller on shaft. Replace impeller washer (270) on the shaft, then the impeller screw (26). Tighten nut securely.



DO NOT USE IMPELLER SCREW TO DRAW IMPELLER ONTO SHAFT. SCREW IS A LOCKING DEVICE ONLY!

3. Position casing gasket (73) on casing (1) and mount casing on casing adapter (71), then tighten nuts (226). Replace strainer (316) on studs (360), replace nuts (361) and tighten.
4. Reassemble grease pipes (335) and force fresh grease into the bearing bushings (39). Also assemble the discharge pipe (161) and tighten nuts (294), tightening the one below the support plate first. Be careful that a strain is not placed on the pump shaft due to improper adjustment of the grease pipe and discharge pipe lock nuts (294).
5. Turn pump shaft (6) by hand several times to make sure that shaft turns freely. Then follow installation instructions.

K - TO INSPECT OR REPLACE THRUST BEARING AND SEAL

1. Disconnect power lines from the motor, then remove motor cap screws (219) and lift motor and motor half of coupling (42) from the motor support (19). Remove the coupling spider and lower half of coupling (42) from the pump shaft (6). Shaft key (46) will come off at this time.
2. Remove adjusting nut (66), then, remove lock washer (69) and unscrew the adjusting nut (66) from the shaft by turning it counter-clockwise. Remove bearing housing bolts and nuts (332) and grease cup (242). Lift the entire assembly consisting of the bearing adapter (170), gib key (244), bearing housing (33), perfect seal (169A), thrust bearing (18), and the shaft perfect seal (169) from the motor support (19).

3. To remove bearing adapter (170), thrust bearing (18), and felt seal (169A) from the bearing housing (33), place a rod through the hole at the shaft sirvene seal (169) and bump gently on the bottom of the bearing adapter (170) moving around its diameter until it is released from the housing. This should be done carefully.
4. To remove the thrust bearing (18) from the bearing adapter (170). The felt seal (169A) can also be pulled from the adapter. The shaft seal (169) should be pushed out of the bearing housing (33) with a rod or piece of wood. Note: When installing a new thrust bearing, we also recommend replacing the two seals (169A) and (169).
5. Press new felt seal (169A) onto bearing adapter (170). Next, press the thrust bearing (18) onto the bearing adapter with the wide space between the bearing races toward the top of the adapter, then replace snap ring. The sirvene seal (169) should be pressed into the bearing housing (33) with the "lip" visible, looking down into the housing. Apply fresh grease to thrust bearing and loosely pack the bearing housing with grease.
6. Place bearing housing (33) in a vise with flange resting on vise jaws. Place bearing adapter assembly over bearing housing (33) and press down on top of adapter to seat thrust bearing (18) in its seat. Lay a piece of wood across the top of the bearing adapter and tap wood to completely seat bearing and perfect seal.
7. Guide the bearing housing and bearing adapter assembly over the shaft. Line up the bolt holes with those in motor support (19) and replace bolts and nuts (332), grease cup (242), and gib key (244). Screw the adjusting nut (66) onto the pump shaft and tighten until shaft just turns free by hand. Turn the adjusting nut (66) two additional flats of the hex nut and replace lock washer (69). Tighten second adjusting nut (66) against lock washer (69).
8. Turn shaft several times by hand to be certain that it turns freely and doesn't bind. Replace the bottom half of coupling (42) and shaft key (46) on the shaft (6). Replace the motor on the motor support (19) engaging the upper and lower halves of coupling (42). Replace cap screws (219) holding motor.

L - COLUMN PIPE DOWEL AND SHAFT GUIDE BEARING ASSEMBLY

The pump construction as shown in cross section on page 9 is a standard for a grease lubricated pump of sufficient length to require an intermediate guide bearing. Pumps specifically designed for handling corrosive, abrasive, or odorous liquids will have materials of construction,

design of guide bearings and lubrication modified for the particular application concerned. The different designs and their application are as follows:

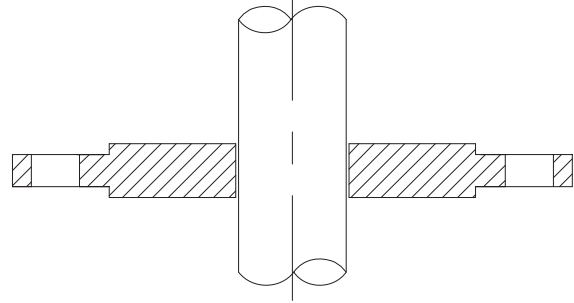

FOR STANDARD DRAINAGE SERVICE -
NONCORROSIVE LIQUIDS WITHOUT ABRASIVES
OR VAPORS

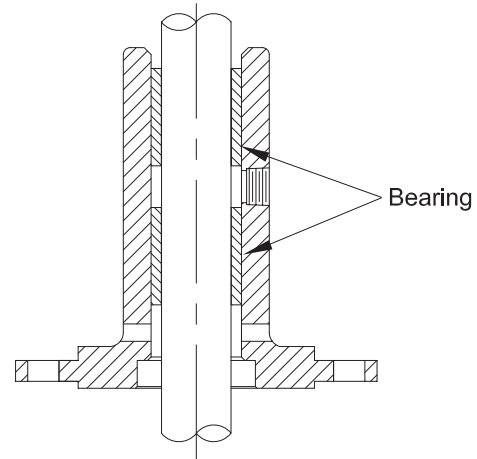

DESIGN 1 - TOP

Design 1 is the standard cast iron column top closure.

DESIGN 8 - INTERMEDIATE

Design 8 is the standard intermediate shaft guide bearing

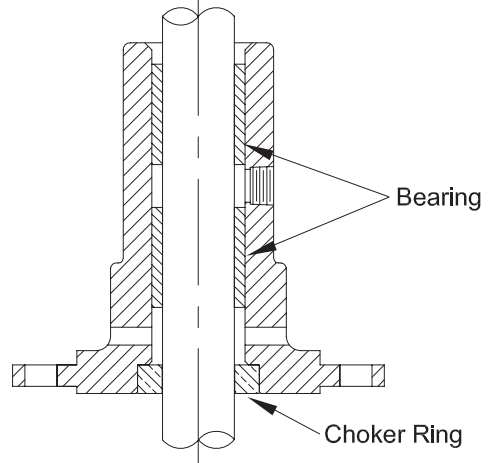

assembly with cast iron bushings and grease lubrication.
(Use with settings of over 6 feet).

DESIGN 6 - BOTTOM

Design 6 is the standard bottom shaft bearing assembly.

The choker ring resists lubricant flushing by the liquid

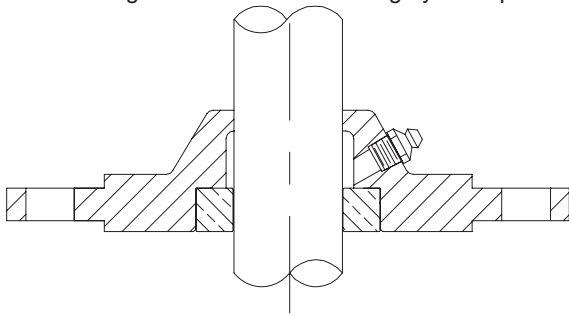

pumped.

FOR SPECIAL PUMPING SERVICES

DESIGN 1A - TOP

For Noncorrosive Vapors which can be contained by

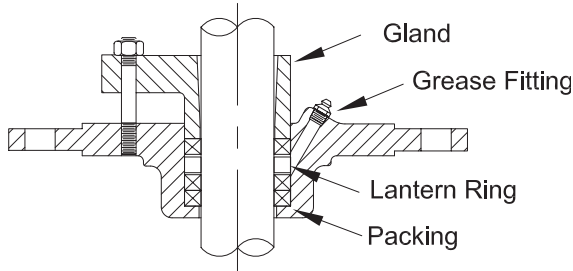

grease-lubricated Top Column Closure. Use instead of Design 1.

DESIGN 3 - TOP

Design 3 For Hot or Corrosive Vapors which can be contained by a stuffing box. Use instead of Design 1. Design 3 also can be fitted with inlet and outlet connections for pressurizing inside of the column with water, air or steam to keep abrasive or corrosive liquids out of the bearing assemblies.

M - LOCATING TROUBLE

1. No water delivered
 - a. Wrong direction of rotation
 - b. Strainer, impeller or pipes plugged
 - c. Discharge head too high
 - d. No water in pit
2. Not enough water delivered
 - a. Strainer, impeller or pipes partly plugged
 - b. Discharge head higher than expected
 - c. Improper impeller adjustment
 - d. Low water level in pit
 - e. Mechanical defects
 1. Impeller worn or damaged
 2. Casing worn
 - f. Wrong direction of rotation
3. Not enough pressure
 - a. Air in water
 - b. Mechanical defects

- c. Impeller diameter too small
- d. Wrong direction of rotation

4. Pump takes too much power
 - a. Speed too high for required head and capacity
 - b. Head lower than rating; pumps too much water
 - c. Liquid either viscous or heavier than water or both
 - d. Mechanical defects
 1. Shaft bent
 2. Impeller binds in casing
 3. Stuffing box packing too tightly adjusted
 - e. Strain on pump caused by piping misalignment
 - f. Liquid pumped leaves a deposit between the shaft and the bearings or between the impeller and the casing.
 - g. Wrong electrical connections

N - Fig. 4560 - 4570

Pump standard sectional assembly and standard parts list apply to pumps of standard construction. Deviations from this construction may result from the use of alternate shaft guide bearing construction or methods of lubrication as described on pages 7 thru 8.

Intermediate guide bearings (33) usually are used only if column length exceeds 5 feet.

Shaft (6) is furnished in two or more lengths coupled together if column length plus liquid end exceeds 10 feet. Discharge pipe coupling (295) is replaced by a flat faced ASA flange on pipe sizes 3" and larger.

Chair bracket mounted units must be realigned every other day during the first week of operation, then once each week until alignment remains constant.

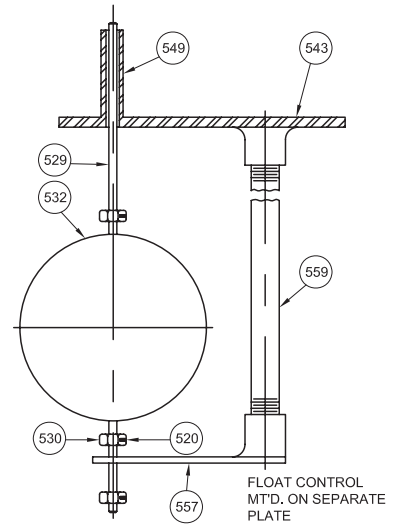
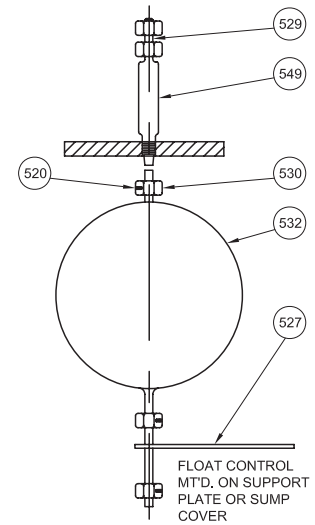
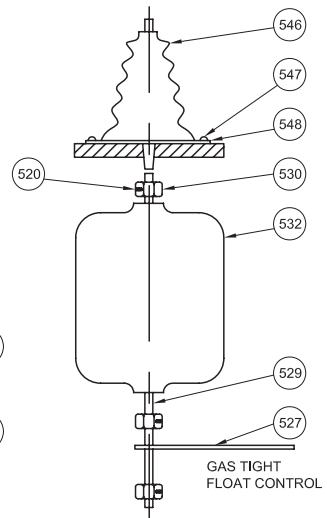
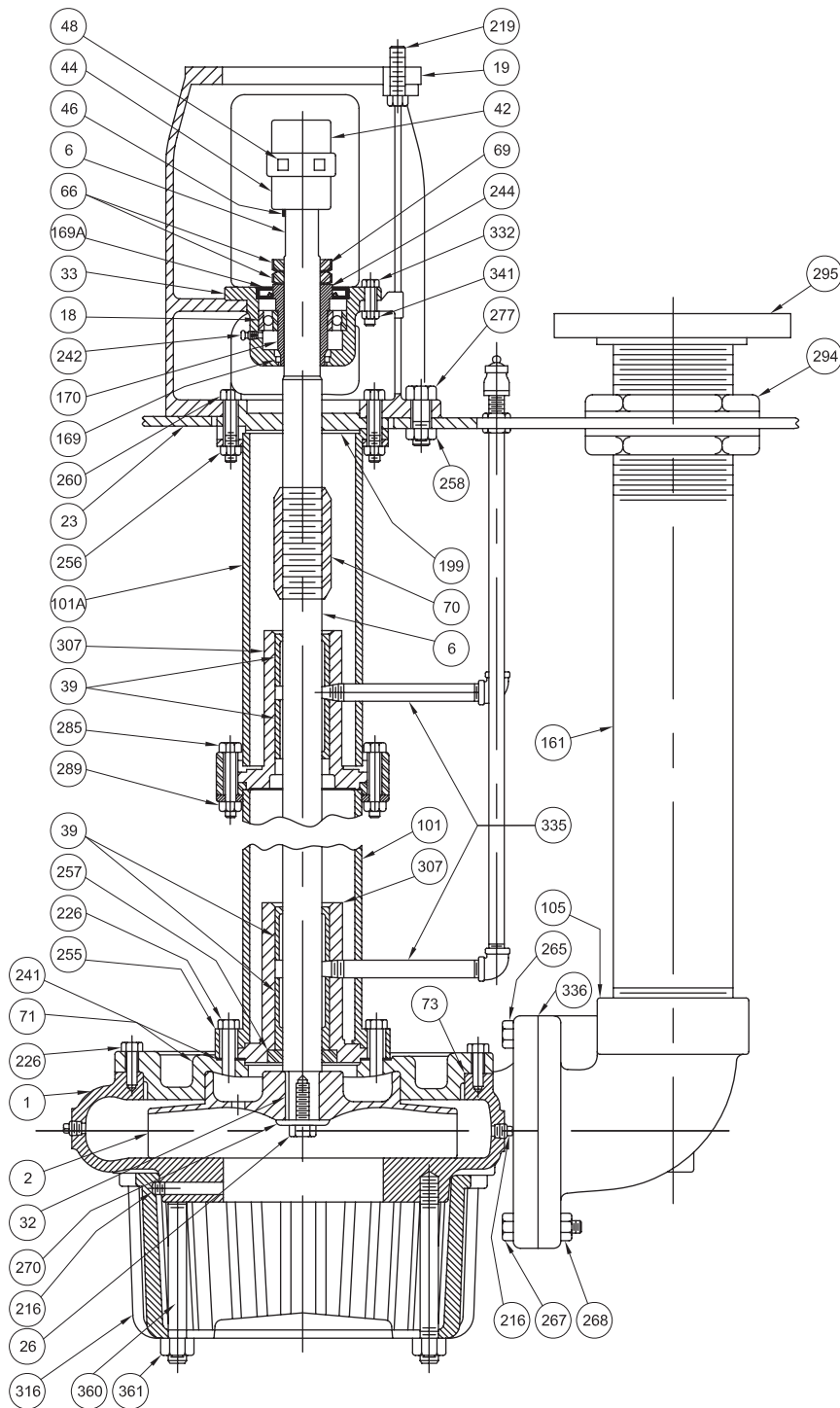

Item No.	Description	Item No.	Description
1	Casing	277	Cap Screw
2	Impeller	285	Cap Screw
6	Shaft	289	Hex Nut
* 18	Ball Bearing	294	Pipe Nut
19	Frame	295	Dishcharge Flange
23	Split Cover Plate	307	Bearing Retainer
* 26	Impeller Screw	316	Strainer
32	Impeller Key	332	Cap Screw
33	Bearing Housing	335	Lube Pipe Assembly
* 39	Bearing Bushing	336	Gasket
42	Coupling Half - Driver	341	Hex Nut
44	Coupling Half - Pump	360	Stud
46	Coupling Key	361	Hex Nut
48	Coupling Spider	520	Set Screw
66	Shaft Adjusting Nut	527	Float Rod Bottom Guide
69	Lock Washer	529	Float Rod
70	Shaft Coupling	530	Float Rod Collars
71	Casing Adapter	532	Float
* 73	Gasket	543	Cover Plate
101	Column Pipe	546	Bellows
101A	Column Pipe - Top	547	Machine Screw
105	Discharge Elbow	548	Washer
161	Discharge Pipe	549	Float Rod Guide Tube
169	Lower Seal	557	Float Guide
169A	Seal-Top	559	Guide Pipe
170	Bearing Adapter		
199	Top Closure		
212	Cap Screw		
216	Pipe Plug		
219	Cap Screw		
226	Cap Screw		
* 241	Gasket		
242	Grease Fitting		
244	Bearing Adapter Key		
250	Frame Gasket		
254	Pipe Nut Gasket		
255	Washer		
256	Hex Nut		
* 257	Choker Ring		
258	Hex Nut		
260	Cap Screw		
265	Cap Screw		
267	Cap Screw		
268	Hex Nut		
270	Impeller Washer		

BARNES®

BARNES®
PRESSURE **PS** SYSTEMS®



burks®

WEINMAN®

DEMING®

PROSSER®

Limited 24 Month Warranty

Crane Pumps & Systems warrants that products of our manufacture will be free of defects in material and workmanship under normal use and service for twenty-four (24) months after manufacture date, when installed and maintained in accordance with our instructions. This warranty gives you specific legal rights, and there may also be other rights which vary from state to state. In the event the product is covered by the Federal Consumer Product Warranties Law (1) the duration of any implied warranties associated with the product by virtue of said law is limited to the same duration as stated herein, (2) this warranty is a LIMITED WARRANTY, and (3) no claims of any nature whatsoever shall be made against us, until the ultimate consumer, his successor, or assigns, notifies us in writing of the defect, and delivers the product and/or defective part(s) freight prepaid to our factory or nearest authorized service station. Some states do not allow limitations on how long an implied warranty lasts, so the above limitation may not apply. **THE SOLE AND EXCLUSIVE REMEDY FOR BREACH OF ANY AND ALL WARRANTIES WITH RESPECT TO ANY PRODUCT SHALL BE TO REPLACE OR REPAIR AT OUR ELECTION, F.O.B. POINT OF MANUFACTURE OR AUTHORIZED REPAIR STATION, SUCH PRODUCTS AND/OR PARTS AS PROVEN DEFECTIVE. THERE SHALL BE NO FURTHER LIABILITY, WHETHER BASED ON WARRANTY, NEGLIGENCE OR OTHERWISE.** Unless expressly stated otherwise, guarantees in the nature of performance specifications furnished in addition to the foregoing material and workmanship warranties on a product manufactured by us, if any, are subject to laboratory tests corrected for field performance. Any additional guarantees, in the nature of performance specifications must be in writing and such writing must be signed by our authorized representative. Due to inaccuracies in field testing if a conflict arises between the results of field testing conducted by or for user, and laboratory tests corrected for field performance, the latter shall control. **RECOMMENDATIONS FOR SPECIAL APPLICATIONS OR THOSE RESULTING FROM SYSTEMS ANALYSES AND EVALUATIONS WE CONDUCT WILL BE BASED ON OUR BEST AVAILABLE EXPERIENCE AND PUBLISHED INDUSTRY INFORMATION. SUCH RECOMMENDATIONS DO NOT CONSTITUTE A WARRANTY OF SATISFACTORY PERFORMANCE AND NO SUCH WARRANTY IS GIVEN.**

This warranty shall not apply when damage is caused by (a) improper installation, (b) improper voltage (c) lightning (d) excessive sand or other abrasive material (e) scale or corrosion build-up due to excessive chemical content. Any modification of the original equipment will also void the warranty. We will not be responsible for loss, damage or labor cost due to interruption of service caused by defective parts. Neither will we accept charges incurred by others without our prior written approval.

This warranty is void if our inspection reveals the product was used in a manner inconsistent with normal industry practice and/or our specific recommendations. The purchaser is responsible for communication of all necessary information regarding the application and use of the product. **UNDER NO CIRCUMSTANCES WILL WE BE RESPONSIBLE FOR ANY OTHER DIRECT OR CONSEQUENTIAL DAMAGES, INCLUDING BUT NOT LIMITED TO TRAVEL EXPENSES, RENTED EQUIPMENT, OUTSIDE CONTRACTOR FEES, UNAUTHORIZED REPAIR SHOP EXPENSES, LOST PROFITS, LOST INCOME, LABOR CHARGES, DELAYS IN PRODUCTION, IDLE PRODUCTION, WHICH DAMAGES ARE CAUSED BY ANY DEFECTS IN MATERIAL AND/OR WORKMANSHIP AND/OR DAMAGE OR DELAYS IN SHIPMENT. THIS WARRANTY IS EXPRESSLY IN LIEU OF ANY OTHER EXPRESS OR IMPLIED WARRANTY, INCLUDING ANY WARRANTY OF MERCHANTABILITY OR FITNESS FOR A PARTICULAR PURPOSE.**

No rights extended under this warranty shall be assigned to any other person, whether by operation of law or otherwise, without our prior written approval.

CRANE[®]

A Crane Co. Company

PUMPS & SYSTEMS

420 Third Street
Piqua, Ohio 45356
Phone: (937) 778-8947
Fax: (937) 773-7157
www.cranepumps.com

83 West Drive, Brampton
Ontario, Canada L6T 2J6
Phone: (905) 457-6223
Fax: (905) 457-2650

**IMPORTANT!
WARRANTY REGISTRATION**

Your product is covered by the enclosed Warranty.
To complete the Warranty Registration Form go to:

<http://www.cranepumps.com/ProductRegistration/>

If you have a claim under the provision of the warranty, contact your local
Crane Pumps & Systems, Inc. Distributor.

RETURNED GOODS

**RETURN OF MERCHANDISE REQUIRES A "RETURNED GOODS AUTHORIZATION".
CONTACT YOUR LOCAL CRANE PUMPS & SYSTEMS, INC. DISTRIBUTOR.**



**Products Returned Must Be Cleaned, Sanitized,
Or Decontaminated As Necessary Prior To Shipment,
To Insure That Employees Will Not Be Exposed To Health
Hazards In Handling Said Material. All Applicable Laws
And Regulations Shall Apply.**