

Contents

1. Identification
2. Installation
3. System design
4. Initial start up
5. Operation
6. Service

1. Identification

The identification label on the water motor states the specific type, the serial number and the code number of the pump, see fig. 1. An arrow indicates the direction of rotation of the water motor.

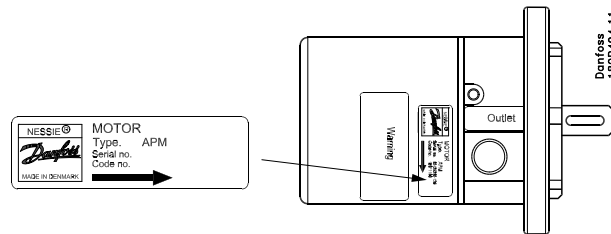

Fig. 1

2. Installation

- 2.1 Mounting
- 2.2 Direction of rotation
- 2.3 Orientation
- 2.4 Protection against too high pressures
- 2.5 Dimensions

2.1 Mounting

If alternative mounting is required, please contact the Danfoss RO Solutions Sales Organisation.

Choose proper tolerances to ensure an easy mounting of the elastic coupling without the use of any tools.

Please observe the recommended length tolerances of the chosen coupling as an axial force on the water motor will damage it.

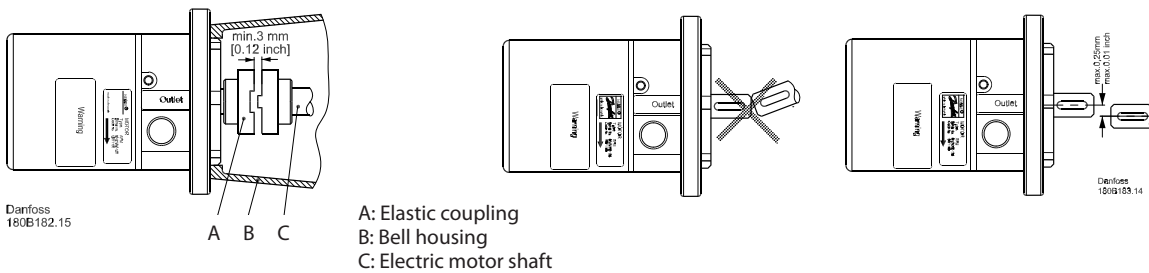

Fig. 2

2.2 Direction of rotation

The direction of rotation is indicated by means of an arrow on the identification label, see section 1.

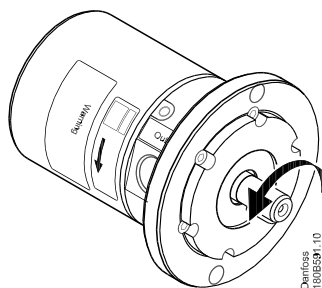

Fig. 3

2.3 Orientation

The water motor can be mounted in any horizontal direction.

Vertically the water motor can only be mounted with the shaft pointing upwards; otherwise air can be trapped inside the water motor and damage it.

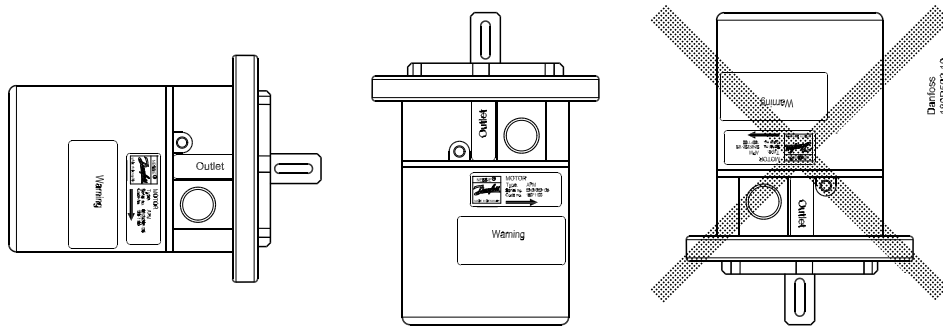

Fig. 4

2.4 Protection against too high pressures

The water motor must be protected against too high pressures by means of a safety valve.

The valve must be placed on the inlet line as close as possible to the water motor.

Pressure peaks in the inlet must not exceed 100 bar (1450 psi).

2.5 Dimensions

Dimensions are shown in mm (in).

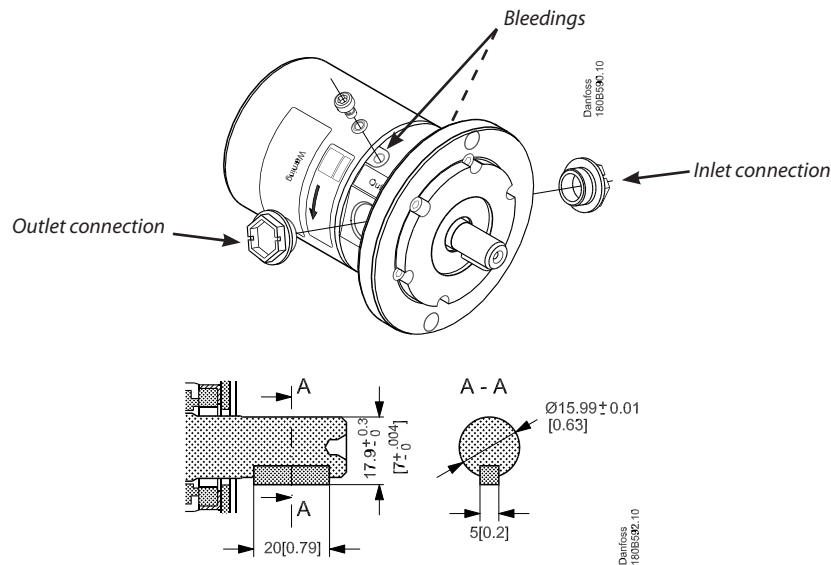

Fig. 5

| Description | APM 0.8 - APM 1.2 | | | APM 1.8 - APM 2.9 | | |
|------------------------|------------------------------------|----------------------|------------------------------------|------------------------------------|----------------------|------------------------------------|
| | Inlet connection | Outlet connection | Bleeding | Inlet connection | Outlet connection | Bleeding |
| Thread size | G 1/2" x 15 | G 1/2" x 15 | M6 Hexagon Width across flat: 4 | G 1/2" x 15 | G 3/4" x 17 | M6 Hexagon Width across flat: 4 |
| Max. tighten torque | 25 Nm (18 lbf-ft) | 25 Nm (18 lbf-ft) | 5 Nm (3.5 lbf-ft) | 25 Nm (18 lbf-ft) | 25 Nm (18 lbf-ft) | 5 Nm (3.5 lbf-ft) |
| Motor mounting flange | SAE A 2 | | | SAE A 2 | | |
| Parallel key, DIN 6885 | 5 x 5 x 20 (0.20 x 0.20 x 0.78) | | | 5 x 5 x 20 (0.20 x 0.20 x 0.78) | | |

Table 1

Recommended torque values refer to steel washers containing a rubber sealing element.

3. System design

- 3.1 Membrane system with energy recovery
- 3.2 Membrane system with energy recovery and bleeding
- 3.3 Important information regarding running water motors in reverse
- 3.4 General comments

The design of the system must ensure that self-emptying of the water motor during standstill is avoided. Always place the outlet line higher than the water motor.

The outlet pressure of the water motor must never exceed the inlet pressure.

Air in the water will cause cavitation and damage the water motor.

As the pressure on the outlet line must not exceed 5 bar, do not throttle the water motor outlet, see fig. 6.

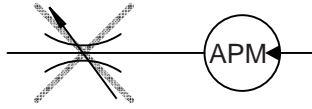

Fig. 6

3.1 Membrane system with energy recovery

In order to eliminate the risk of damage and cavitation, observe the following guidelines:

1. Place an inlet filter (1) in front of the HP pump (2).
2. Design the inlet and outlet lines to obtain minimum pressure loss (large flow area, minimum pipe length, minimum number of bends/connections, fittings with small pressure losses) (3).
3. In order to avoid risk of cavitation, the pressure at the inlet (4) of the water motor must be min. 10 bar (145 psi).

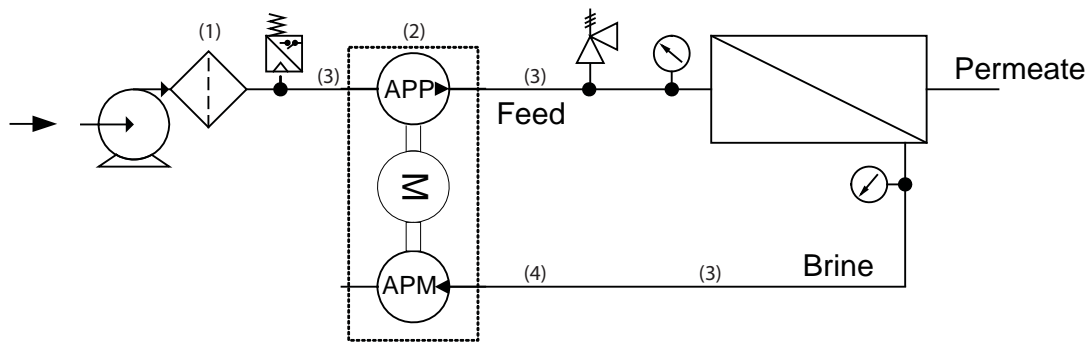

Fig. 7

3.2 Membrane with energy recovery and bleeding

In order to eliminate the risk of damage and cavitation, observe the following guidelines:

1. For easy system bleeding, apply a bypass non-return valve (1) in parallel with the HP pump.
2. Place an inlet filter (2) in front of the HP pump (3).
3. Dimension the inlet line to obtain minimum pressure loss (large flow area, minimum pipe length, minimum number of bends/connections, fittings with small pressure losses) (4).
4. In order to avoid risk of cavitation, the pressure at the inlet (5) of the water motor must be min. 10 bar (145 psi).

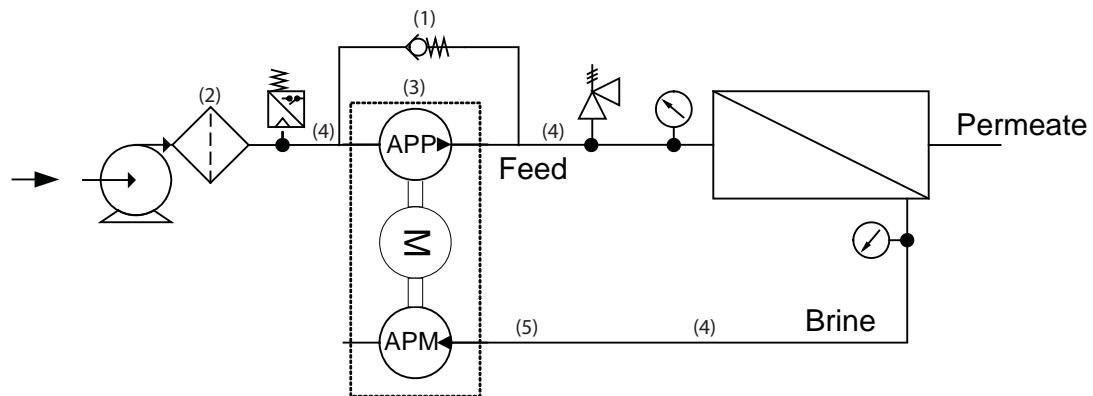

Fig. 8

3.3 Important information regarding running water motors in reverse

If acceleration does not exceed the curve shown below, running reverse with the electrical motor will not harm the water motor as long as the pressure in the outlet does not exceed the max. pressure of 5 bar (72.5 psi).

The outlet line connection must be properly tightened as possible entrance of air will cause cavitation.

Note: If the water motor is run in reverse, do not mount a non-return valve on the outlet line.

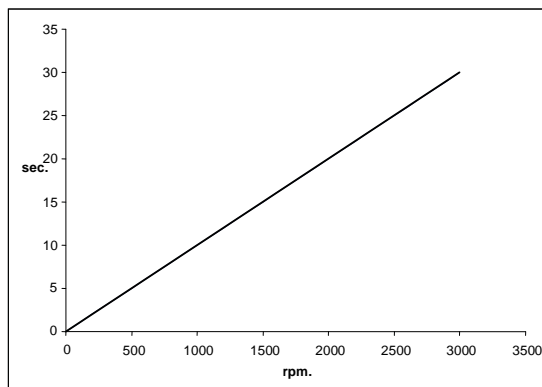

Fig. 9 Acceleration curve

3.4 General comments

Filtration

Good filtration is vital to ensure a long and trouble-free life of the water motor.

When selecting a filter or strainer, please note that filter materials should be resistant to seawater, i.e. they should neither corrode nor dissolve. For more information on filters, contact the Danfoss RO Solutions Sales Organisation.

Be aware of the risk of galvanic corrosion when designing the system by observing the electrochemical series of the materials used.

The main filter must have a filtration efficiency of 10 μm abs.; $\beta_{10} > 5000$ (99.98%).

The pressure loss across the filter should be monitored.

Monitoring

It is recommended to continuously monitor the following conditions:

- membrane contamination
- pressure (inlet and outlet side of the water motor)
- water temperature

4. Initial start-up

4.1 Energy recovery setup

4.2 Energy recovery with bleeding bypass setup

4.1 Energy recovery setup

1. With the water motor disconnected from the inlet line and from the electrical motor, the system must be flushed before start-up in order to remove possible impurities from pipes, hoses, membranes etc. Duration of system flush: 1 minute.
2. Connect the water motor to the electrical motor and to the inlet line.
3. Loosen the top bleeding plug. Run the water motor until water appears from the bleeding plug. Then stop the water motor and retighten the plug.

4.2 Energy recovery with bleeding bypass setup

1. With the water motor disconnected from the inlet line, the system should be flushed by the booster pump alone before start-up in order to remove possible impurities from pipes, hoses, membranes etc. Duration of system flush: 1 minute.
2. Connect the water motor to the inlet line.
3. Loosen the top bleeding plug. Run the water motor until water appears from the bleeding plug. Then stop the water motor and retighten the plug.

Warning: Make sure that the direction of rotation of the electric motor corresponds to the intended direction of rotation of the water motor. Otherwise the system will be damaged.

5. Operation

- 5.1 Temperature
- 5.2 Pressure
- 5.3 Dry running
- 5.4 Disconnection
- 5.5 Shaft load
- 5.6 Transport and storage precautions

If the water motor is to be out of operation, it must be flushed with fresh water to avoid corrosion.

5.1 Temperature

Fluid temperature: Min. +3°C to max. +50°C (dependent on the NaCl concentration).

The chart illustrates corrosive resistance of different types of stainless steel related to NaCl concentration and temperature.

The APM water motor is made of SAF 2507.

If the water motor is operated above the SAF 2507 line, always flush the the water motor with fresh water at operation stop in order to minimise the risk of crevice corrosion.

Ambient temperature: Min. 0°C to max. +50°C.

Storage temperature: Min. -40°C to max. +70°C.

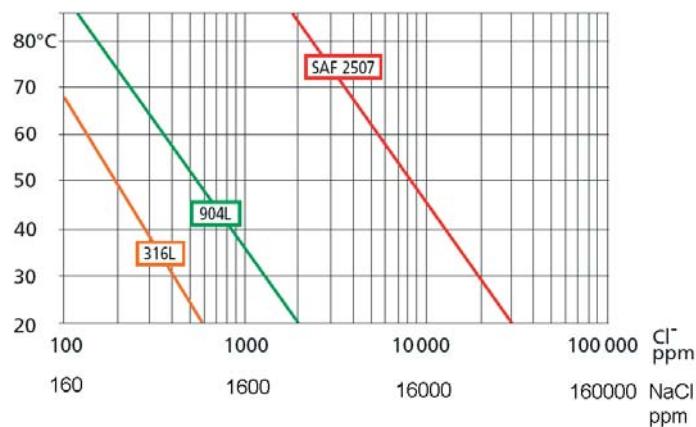

Fig. 10 NaCl vs. temperature

5.2 Pressure

The inlet pressure must be min. 10 bar (145 psi) and max. 80 bar (1160 psi) continuously. By long term use, the pressure on the inlet line must be above 1 bar (14,5 psi). Otherwise the the water motor will cavitate, resulting in damage to the the water motor.

Pressure peaks of up to 100 bar (1450 psi) on the inlet line are acceptable.

Pressure on the outlet line of the the water motor must be max. 5 bar (72.5 psi) continuously.

The the water motor unit should include a pressure gauge on the high pressure side.

5.3 Dry running

As high pressure water is used for lubrication, avoid dry-running of the the water motor. Dry-running will damage the the water motor.

5.4 Disconnection

If the inlet or outlet line is disconnected from the the water motor, the water motor will be emptied of water through the disconnected lines.

When starting up again, follow the bleeding procedure described under section 4: Initial start-up.

5.5 Shaft load

Do not expose the the water motor shaft to radial or axial load.

5.6 Transport and storage precautions

When preparing the the water motor for long-term storage or for temperatures below freezing point, flush the the water motor with an anti-freeze medium type monopropylene glycol to prevent internal corrosion or frost bursts in the the water motor.

For further information on anti-freeze media, please contact the Danfoss RO Solutions Sales Organization.

Recommended procedure

1. Flush system with an anti-freeze medium type monopropylene glycol. Through the lower bleeding plug empty the the water motor housing of water and close the plug again. Open the upper bleeding plug, quickly start and stop the unit. It is recommended that components not tolerant to the anti-freeze medium are removed from the system before flushing it. The the water motor is now protected against internal corrosion and frost bursts.
2. Dismount the the water motor from the unit. Empty the the water motor of water and pour glycol into the outlet port and rotate the shaft with your hand. The water motor is now protected against internal corrosion and frost bursts.

6. Service

6.1 Periodic maintenance

6.2 Repair

6.1 Periodic maintenance

Water acts as lubricant in the APM the water motor. Thus there is no oil in the the water motor.

By operation below the curve for SAF 2507 in fig. 10, section 5.1, no parts are expected to be replaced within the first 8000 hours of operation. It is recommended to inspect the internal parts after 4000 hours of operation, though.

If the the water motor is to be returned to Danfoss for service, see section 5.6 for transport precautions.

6.2 Repair

In case of irregular function in the motor, please contact the Danfoss RO Solutions Sales Organisation.