



7 Frame Plunger Pump

Models

530
550

FEATURES

Superior Design

- Triplex plunger design gives smoother fluid flow.
- Hi-Pressure Seals are completely lubricated and cooled by the fluid being pumped.
- Inlet and discharge valve assemblies interchange for easier maintenance.
- Lubricated Lo-Pressure Seals provide double protection against external leakage.
- Oil bath crankcase assures optimum lubrication.
- Close tolerance concentricity of the ceramic plunger maximizes seal life.
- Convenient Gearbox Pump version for direct mounting to gas engine.

Quality Materials

- All stainless steel valves are heat treated and seats are roller burnished for a positive seal and extended valve life.
- Forged brass manifold is strong and corrosion resistant.
- Special concentric, high density, polished, graphite impregnated, solid ceramic plungers are abrasion resistant and result in extended seal life.
- Specially formulated, CAT PUMP exclusive, Hi-Pressure Seals offer unmatched performance and seal life.
- Die cast aluminum crankcase provides high strength, minimum weight and precision tolerance control.
- Chrome-moly crankshaft gives unmatched strength and surface hardness.
- Oversized crankshaft bearings with greater capacity mean longer bearing life.

Easy Maintenance

- Wet end is easily serviced without entering crankcase, requiring less time and effort.
- Valve assemblies are accessible without disturbing piping, for quick service.
- Preset packings mean no packing gland adjustment is necessary, reducing maintenance costs.

DETERMINING THE PUMP R.P.M. $\frac{\text{Rated G.P.M.}}{\text{Rated R.P.M.}} = \frac{\text{"Desired" G.P.M.}}{\text{"Desired" R.P.M.}}$

DETERMINING THE REQUIRED H.P. $\frac{\text{GPM} \times \text{PSI}}{1460} = \text{Electric Brake H. P. Required}$

DETERMINING MOTOR PULLEY SIZE $\frac{\text{Motor Pulley O.D.}}{\text{Pump R.P.M.}} = \frac{\text{Pump Pulley O.D.}}{\text{Motor R.P.M.}}$

Note: Consult engine manufacturer when using gas or diesel engine. Refer to pump Service Manual for important Inlet Condition Check-List, Start-up Procedure, Tech Bulletins and Pump Maintenance information.

SPECIFICATIONS

	U.S. Measure	Metric Measure
MODEL 530		
Volume	5.0 GPM	(19 L/M)
Discharge Pressure	100 to 2500 PSI	(7 to 175 BAR)
RPM	1100 RPM	(1100 RPM)
Bore.....	0.708"	(18 mm)
Stroke.....	0.945"	(24 mm)

MODEL 550		
Volume	5.0 GPM	(19 L/M)
Discharge Pressure	100 to 3000 PSI	(7 to 210 BAR)
RPM	1415 RPM	(1415 RPM)
Bore.....	0.630"	(16 mm)
Stroke.....	0.945"	(24 mm)

COMMON SPECIFICATIONS

Max. Inlet Pressure.....	Flooded to 60 PSI	(Flooded to 4 BAR)
Crankcase Capacity	25 oz.	(0.75 L)
Maximum Fluid Temperature.....	160°F	(71°C)
Inlet Ports (2)	1/2" NPT	(1/2" NPT)
Discharge Ports (2)	3/8" NPT	(3/8" NPT)
Shaft Diameter	0.945"	(24 mm)
Weight.....	25.5 lbs.	(11.5 kg)
Dimensions.....	13.6" x 9.61" x 6.41"	(346 x 244 x 163 mm)

HORSEPOWER REQUIREMENTS

MODEL	FLOW		PRESSURE				MOTOR PULLEY SIZE	
			PSI 1800	PSI 2150	PSI 2500	PSI 3000	Using 1725 RPM Motor & Std. 9.75" Pulley O.D.	
	U.S. GPM	L/M	BAR 125	BAR 150	BAR 175	BAR 210	RPM	Pulley O.D.
530	5.0	19	6.2	7.4	8.6	N/A	1100	6.3
	4.5	17	5.6	6.6	7.7	N/A	990	5.6
	4.0	15	4.9	5.9	6.9	N/A	880	5.0
550	5.0	19	6.2	7.4	8.6	10.3	1415	8.0
	4.0	15	4.9	5.9	6.9	8.2	1130	6.4
	3.0	11	4.3	4.4	5.2	6.2	850	5.0

See complete Drive Packages [Incls: Pulleys, Belts, Hubs, Key] Tech Bulletin 03.

"Customer confidence is our greatest asset"

PARTS LIST

ITEM	PART NUMBER		DESCRIPTION		QTY
	530	MATL	550	MATL	
● 2	30067	STL	30067	STL	Key (M8x7.5x25) 1 ●
5	92519	STZP	92519	STZP	Screw, Sems HHC (M6x16) 4
8	43223	AL	43223	AL	Cover, Bearing 2
9	43261		43261		Shim, Bearing Cover (2-pc) 1
10	12393	NBR	12393	NBR	O-Ring, Bearing Cover 2
11	43222	NBR	43222	NBR	Seal, Oil 2
15	43221	STL	43221	STL	Bearing, Roller 2
20	46302	HS	46302	HS	Rod, Assy, Connecting 3
25	43220	FCM	43220	FCM	Crankshaft, Dual End 1
31	828710		828710		Protector, Oil Cap 1
32	43211		43211		Cap, Oil Filler 1
33	14177	NBR	14177	NBR	O-Ring, Filler Cap 1
37	43987		43987		Gauge, Oil, Bubble - 80 1
38	44428	NBR	44428	NBR	Gasket, Flat 1
40	92520	STZP	92520	STZP	Screw, Sems HHC (M6x20) 4
48	25625	STCP	25625	STCP	Plug, Drain (1/4"x11) 1
49	23170	NBR	23170	NBR	O-Ring, Drain Plug 1
50	43217	AL	43217	AL	Cover, Crankcase 1
51	44836	NBR	44836	NBR	O-Ring, Crankcase Cover - 70 1
53	○ 45056	AL	○ 45056	AL	Crankcase (M10) 1
56	43240	POP	43240	POP	Pan, Oil 1
64	43237	S	43237	S	Pin, Rist 3
65	43229	CPZZ	43229	CPZZ	Rod, Plunger 3
69	43227	STZP	43227	STZP	Washer, Oil Seal 3
70	43228	NBR	43228	NBR	Seal, Oil, Crankcase 3
75	43328	S	43328	S	Slinger, Barrier 3
88	45697	S	45697	S	Washer, Keyhole (M18) 3
90	43232	CC	43311	CC	Plunger 3
96	43235	PTFE	43235	PTFE	Back-up-Ring, Plunger Retainer 3
97	17399	NBR	17399	NBR	O-Ring, Plunger Retainer - 80 3
	14160	FPM	14160	FPM	O-Ring, Plunger Retainer 3
98	45891	CU	45891	CU	Gasket, Plunger Retainer 3
99	104360	S	104360	S	Retainer, Plunger w/Stud 3
100	⋮ 45686	PVDF	⋮ 45686	PVDF	Retainer, Seal, Rear 3
	⋮ 45687	PVDF	⋮ 45687	PVDF	Retainer, Seal, Adapter, Front 3
101	43239		43313		Wick, Long Tab 3
106	43243	NBR	43316	NBR	Seal, LPS w/S-Spg 3
	44926	FPM	106660	FPM	Seal, LPS w/S-Spg 3
120	⋮ 45683	BB	⋮ 45684	BB	Case, Seal 3
121	20285	NBR	20285	NBR	O-Ring, Seal Case - 70 3
	11693	FPM	11693	FPM	O-Ring, Seal Case 3
125	43245	NBR	—		Seal, HPS w/S 3
	44925	FPM	—		Seal, HPS w/SS 3
126	—		43320	BB	Adapter, Female 3
127	—		43319	PTFE	V-Packing 6
	—		46287	HT	V-Packing, White [STG] 6
128	—		43318	BB	Adapter, Male 3
139	22179	BBCP	22179	BBCP	Plug (1/2" NPT) 1
162	43248	PTFE	43248	PTFE	Back-up-Ring, Valve Seat 6
163	43249	NBR	43249	NBR	O-Ring, Seat 6
	44383	FPM	44383	FPM	O-Ring, Seat 6
164	43722	S	43722	S	Seat, Valve, Q.V. 6
	43825	S	—		Seat, Valve, F.V. 6
166	43721	S	43721	S	Valve, Q.V. 6
	43824	S	—		Valve, F.V. 6
167	43751	S	43751	S	Spring, Valve, Q.V. 6
	43823	S	—		Spring, Valve, F.V. 6
168	44564	PVDF	44564	PVDF	Retainer, Spring 6
172	17617	NBR	17617	NBR	O-Ring, Valve Plug - 90 6
	11691	FPM	11691	FPM	O-Ring, Valve Plug 6
174	43851	BBCP	43851	BBCP	Plug, Valve 6
185	○ 45417	BBCP	○ 45547	BBCP	Head, Manifold (M10F) 1
187	○ 46868	S	○ 46868	S	Stud, Manifold (M10x35) 4
194	○ 45550	STZP	○ 45550	STZP	Nut, Flanged (M10) 4
196	43633	BB	43633	BB	Plug, Discharge (3/8" NPT) 1
250	43256	STZP	43256	STZP	Protector, Shaft 1
255	30243	STZP	30243	STZP	Kit, Direct Mounting 1
260	30645	STZP	30645	STZP	Rail, Angle, Assy A-U.S. (Incls: 30635, 30900, 30910, 30920) 1
	30611	STZP	30611	STZP	Rail, Angle, Assy B-U.S. (Incls: 28499, 30900, 30910, 30920) 1
265	30660		30660		Kit, Mounting (Incls: 30645, 30206, 33000, 30067, 43256) 1
● 269	30206	F	30206	F	Pulley (9.75") [See complete Drive Packages, Tech Bulletin 03] 1 ●
● 274	33000	STL	33000	STL	Hub "H", M24 (Keyway M8) [See complete Drive Packages, Tech Bulletin 03] 1 ●
● 283	34334		34334		Kit, Oil Drain 1 ●
● 299	812183	CPBB	812184	CPBB	Head, Complete 1 ●
300	30488	NBR	30610	NBR	Kit, Seal (Incls: 97, 101, 106, 121, 125, 127) 1
310	30820	NBR	30820	NBR	Kit, Valve, Q.V. (Incls: 162-164, 166, 167, 168, 172) 2
	31820	NBR	—	NBR	Kit, Valve, F.V. (Incls: 162-164, 166, 167, 168, 172) 2
350	30696	STZP	30696	STZP	Tool, Valve Seat Removal 1
351	43257	STZP	43257	STZP	Tool, Seal Case Removal 1
352	44050	STZP	44050	STZP	Tool, Oil Gauge Removal 1
	6565.1		6565.1		Plunger Pump Service Video 1

● Industrial discount. **Bold print part numbers are unique to a particular pump model.** *Italics are optional items.*

Refer to Tech Bulletins 03, 08, 24, 27, 35, 36, 43, ○ 51, 53, ⋮ 54, 74 and 77 for additional information.

MATERIAL CODES (Not Part of Part Number): AL=Aluminum BB=Brass BBCP=Brass/Chrome Plated CC=Ceramic CPZZ=Zamak/Chrome Plated
 CU=Copper F=Cast Iron FBB=Forged Brass FCM=Forged Chrome-moly FPM=Fluorocarbon (Viton®) HT=Hi-Temp (EPDM Alternative) HS=High Strength
 NBR=Medium Nitrile (Buna-N) POP=Polypropylene PTFE=Polytetrafluoroethylene (Teflon®) PVDF=Fluoroplastic (High Strength)
 S=304SS STCP=Steel/Chrome Plated STL=Steel STZP=Steel/Zinc Plated

EXPLODED VIEW

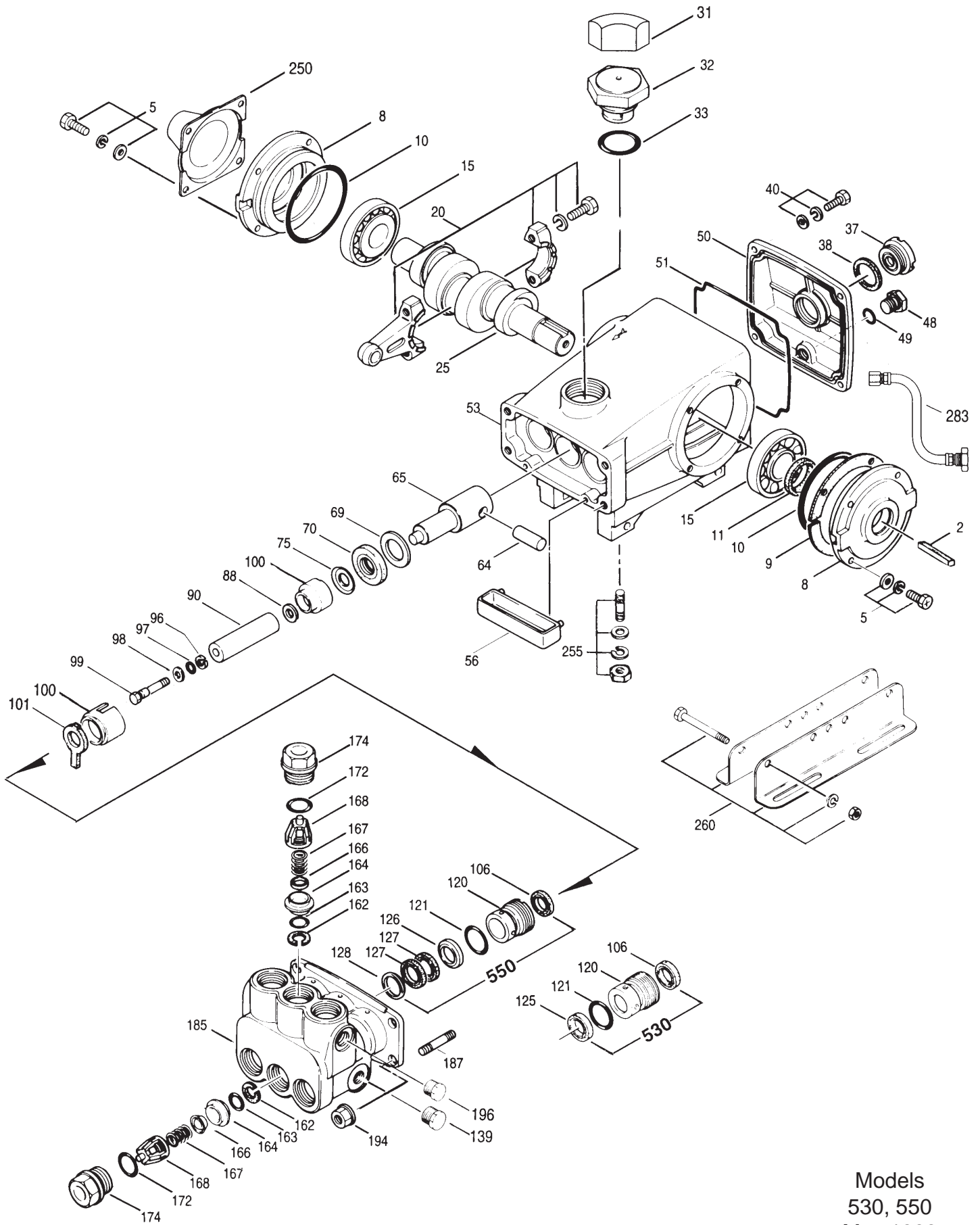

Models
530, 550
May 1998

