

5 Frame Plunger Pump

Model

45

FEATURES

Superior Design

- Triplex plunger design gives smoother fluid flow.
- V-Packings are completely lubricated and cooled by the fluid being pumped.
- Inlet and discharge valve assemblies interchange for easier maintenance.
- Lubricated Lo-Pressure Seal provides double protection against external leakage.
- Oil bath crankcase assures optimum lubrication.
- Close tolerance concentricity of the ceramic plunger maximizes seal life.
- Optional Gearbox version for direct mounting to gas engine.

Quality Materials

- All stainless steel valves are heat treated and seats are roller burnished for a positive seal and extended valve life.
- Forged brass manifold for strength and corrosion resistance.
- Special concentric, high density, polished, graphite impregnated, solid ceramic plungers are abrasion resistant and result in extended seal life.
- Specially formulated, CAT PUMP exclusive, V-Packings offer unmatched performance and seal life.
- Die cast aluminum crankcase provides high strength, minimum weight and precision tolerance control.
- Chrome-moly crankshaft gives unmatched strength and surface hardness.
- Oversized crankshaft bearings with greater loading capacity means longer bearing life.

Easy Maintenance

- Wet end is easily serviced without entering crankcase, requiring less time and effort.
- Valve assemblies are accessible without disturbing piping, for quick service.
- Preset packings mean no packing gland adjustment is necessary, reducing maintenance costs.

SPECIFICATIONS

	U.S. Measure	Metric Measure
MODEL 45		
Flow.....	4.5 GPM	(17 L/M)
Discharge Pressure.....	100 to 3500 PSI	(7-245 BAR)
Inlet Pressure.....	Flooded to 60 PSI	(Flooded to 4 BAR)
RPM.....	1645 RPM	(1645 RPM)
Bore.....	0.630"	(16 mm)
Stroke.....	0.708"	(18 mm)
Crankcase Capacity.....	18 oz.	(0.55 L)
Maximum Fluid Temperature.....	160°F	(71°C)
Inlet Ports (2).....	1/2" NPTF	(1/2" NPTF)
Outlet Ports (2).....	3/8" NPTF	(3/8" NPTF)
Shaft Diameter - Single End.....	0.787"	(20 mm)
Weight.....	20.9 lbs.	(9.5 kg)
Dimensions.....	12.0" x 8.35" x 5.5"	(304.5 x 212 x 139 mm)

HORSEPOWER REQUIREMENTS

FLOW		PRESSURE					MOTOR PULLEY SIZE	
		PSI 1500	PSI 2000	PSI 2500	PSI 3000	PSI 3500	Using 1725 RPM Motor & 7.0" Pump Pulley	
U.S. GPM	L/M	BAR 100	BAR 140	BAR 175	BAR 210	BAR 245	RPM	Pulley O.D.
4.0	15	4.1	5.5	6.9	8.3	9.6	1455	5.4
4.5	17	4.7	6.2	7.7	9.3	10.8	1645	6.0
4.5	17	4.7	6.2	7.7	9.3	10.8	1645	Gearbox

See complete Drive Packages [Incls: Pulleys, Belts, Hubs, Key] Tech Bulletin 03.

DETERMINING THE PUMP R.P.M. $\frac{\text{Rated G.P.M.}}{\text{Rated R.P.M.}} = \frac{\text{"Desired" G.P.M.}}{\text{"Desired" R.P.M.}}$

DETERMINING THE REQUIRED H.P. $\frac{\text{GPM x PSI}}{1460} = \text{Electric Brake H. P. Required}$

DETERMINING MOTOR PULLEY SIZE $\frac{\text{Motor Pulley O.D.}}{\text{Pump R.P.M.}} = \frac{\text{Pump Pulley O.D.}}{\text{Motor R.P.M.}}$

Note: Consult engine manufacturer when using gas or diesel engine. Refer to pump Service Manual for important Inlet Condition Check-List, Start-up Procedure, Tech Bulletins and Pump Maintenance information.

PARTS LIST

ITEM	P/N	MATL	DESCRIPTION	QTY
2	30057	STL	Key (M6x6)	1
5	96031	STZP	Screw, Sems HHC (M8x16)	8
8	45951	AL	Bearing Cover (M8)	1
10	43343	NBR	O-Ring, Bearing Cover	2
11	43222	NBR	Seal, Oil, Crankshaft	1
15	14480	STL	Bearing, Ball	2
20	45883	ZZ	Rod, Connecting Assy	3
25	45911	FCM	Crankshaft - Single End	1
30	45953	AL	Cover, Blind Shaft (M8)	1
31	828710		<i>Protector, Oil Cap</i>	1
32	44666	RTP	Cap, Oil Filler, Domed	1
33	14177	NBR	O-Ring, Oil Filler Cap	1
37	43987		Gauge, Oil, Bubble	1
38	44428	NBR	Gasket, Flat, Oil Gauge	1
40	92519	STZP	Screw, Sems HHC (M6x16)	4
48	25625	STCP	Plug, Drain (1/4"x11)	1
49	23170	NBR	O-Ring, Drain Plug	1
50	44222	AL	Cover, Crankcase	1
51	43340	NBR	O-Ring, Crankcase Cover	1
● 53	45966	AL	Crankcase (M8)	1 ●
64	43351	S	Pin, Rist	3
65	45908	CPZZ	Rod, Plunger	3
70	43228	NBR	Seal, Oil, Crankcase	3
75	43328	S	Slinger, Barrier	3
88	45697	S	Washer, Keyhole	3
90	45783	CC	Plunger (M72)	3
95	89648	STZP	Stud, Plunger Retainer (M6x64.5)	3
96	43235	PTFE	Back-up-Ring, Plunger Retainer	3
97	17399	NBR	O-Ring, Plunger Retainer - 80	3
	14160	FPM	<i>O-Ring, Plunger Retainer</i>	3
98	45891	CU	Gasket, Plunger Retainer	3
99	46504	S	Retainer, Plunger	3
100	45681	PVDF	Retainer, Seal, Rear	3
	45687	PVDF	Retainer, Seal Adapter, Front	3
106	43316	NBR	Seal, LPS w/Spg	3
	106660	FPM	<i>Seal, LPS w/Spg</i>	3
120	45789	BB	Case, Seal	3
121	14200	NBR	O-Ring, Seal Case - 70	3
	11719	FPM	<i>O-Ring, Seal Case</i>	3
126	43320	BB	Adapter, Female	3
127	43319	PTFE	V-Packing	6
	46287	HT	<i>V-Packing, White, STG</i>	6
128	43318	BB	Adapter, Male	3
163	17547	NBR	O-Ring, Valve Seat	6
	11685	FPM	<i>O-Ring, Valve Seat</i>	6
164	45790	S	Seat, Valve	6
166	45899	S	Valve	6
167	43750	S	Spring	6
168	44565	PVDF	Retainer, Spring	6
172	17549	NBR	O-Ring, Valve Plug - 70	6
	26996	FPM	<i>O-Ring, Valve Plug</i>	6
173	48365	D	Back-up-Ring, Valve Plug	6
174	45900	BB	Plug, Valve	6
185	45907	BB	Manifold Head	3
186	12503	STZP	Lockwasher, Split (M10)	2
188	87931	STZP	Srew, HSH (M10x35)	2
260	30611	STZP	<i>Rail, Angle Assy, Low-B (Incls: 28499, 30900, 30910, 30920)</i>	1
260	30645	STZP	<i>Rail, Angle Assy, High-A (Incls: 30635, 30900, 30910, 30920)</i>	1
275	30944	STL	<i>Hub & Key Assy, "H" Series, M20, (M6 Key) (Incls: 30057, 30945)</i>	1
			[See complete Drive Accessory Packages, Tech Bulletin 03]	
● 283	34334		<i>Kit, Oil Drain</i>	1 ●
300	30629	NBR	<i>Kit, Seal (Incls: 97, 106, 121, 127)</i>	1
310	30683	S	<i>Kit, Valve (Incls: 163, 164, 166, 167, 172, 173)</i>	2
350	30696	STZP	<i>Tool, Valve Seat Removal</i>	1
351	43257	STZP	<i>Tool, Seal Case Removal</i>	1
	33004	STZP	<i>Socket, Seal Case (1/2" Drive)</i>	1
—	6565.1		<i>Plunger Pump Service Video, Section I</i>	1

● Industrial discount. *Italics are optional items.*

See Tech Bulletins 03, 24, 35, 36, 43, 54, 67, 74 and 77 for additional information.

See 8051-8078 Gearbox Specification sheet for direct drive gas engine options.

MATERIAL CODES (Not Part of Part Number): AL=Aluminum BB=Brass CC=Ceramic CPZZ=Zamak/Chrome Plated CU=Copper D=Delryn® FCM=Forged Chrome-moly FPM=Fluorocarbon (Viton®) HT=Hi-Temp (EPDM Alternative) NBR=Medium Nitrile (Buna-N) PTFE=Polytetrafluoroethylene (Teflon®) PVDF=Fluoroplastic (High Strength) RTP=Reinforced Composite S=304SS STCP=Steel/Chrome Plated STL=Steel STZP=Steel/Zinc Plated ZZ=Zamak

EXPLODED VIEW

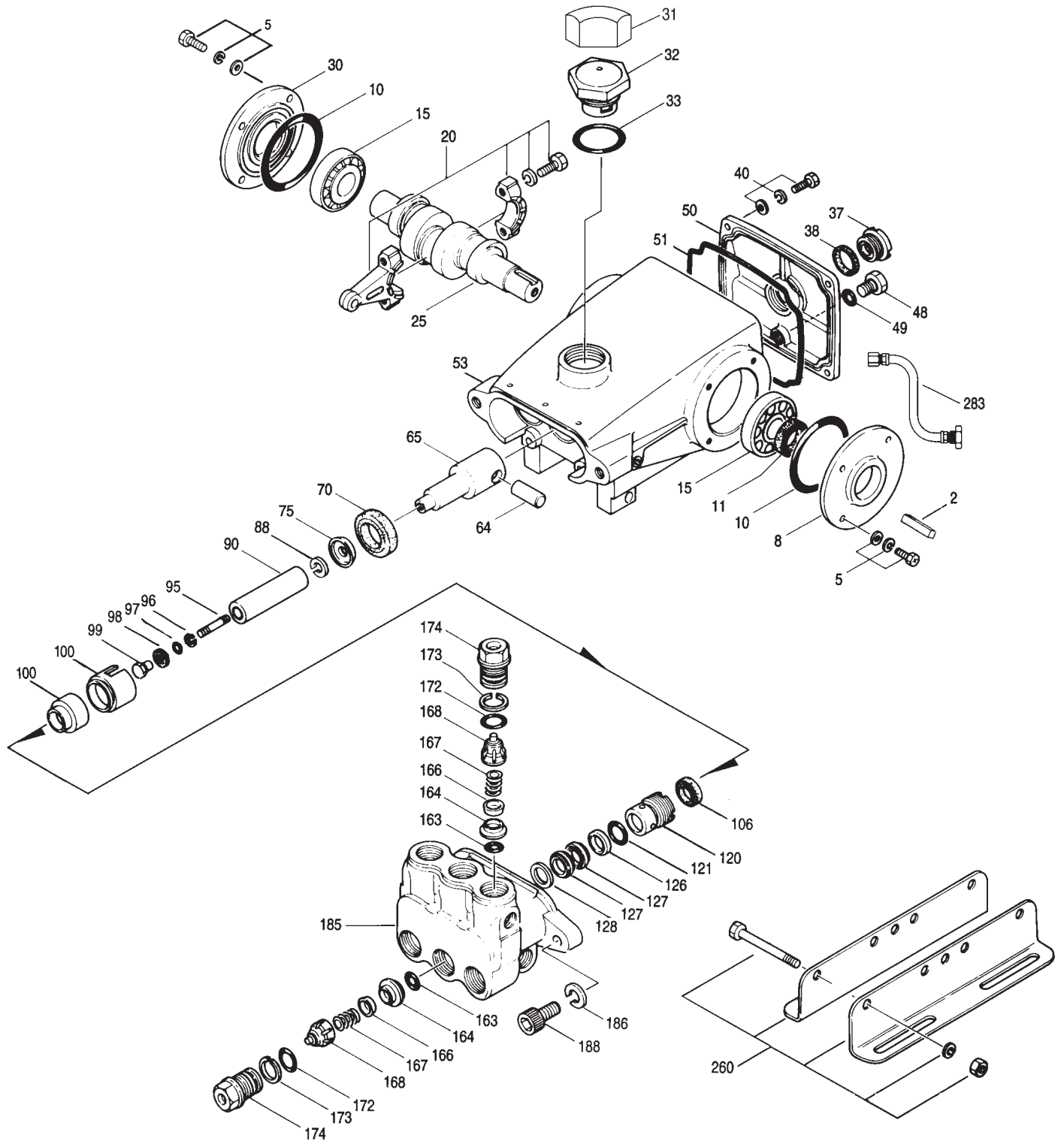

Model
45
November 1998

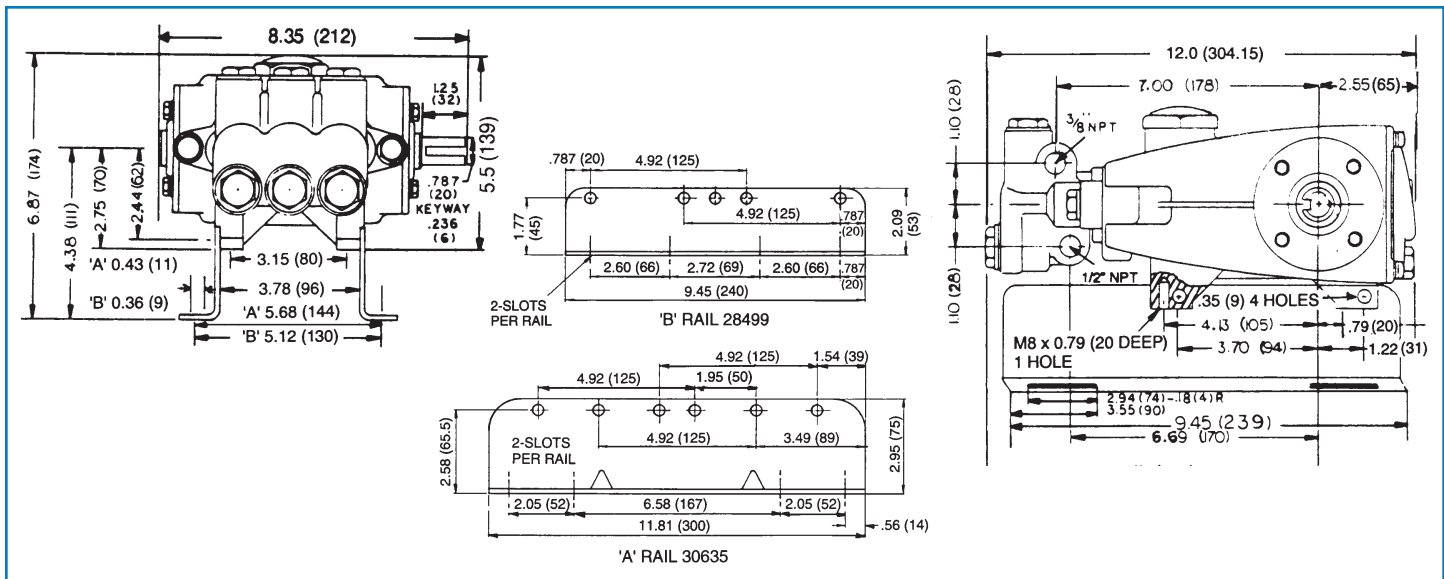

Model 45

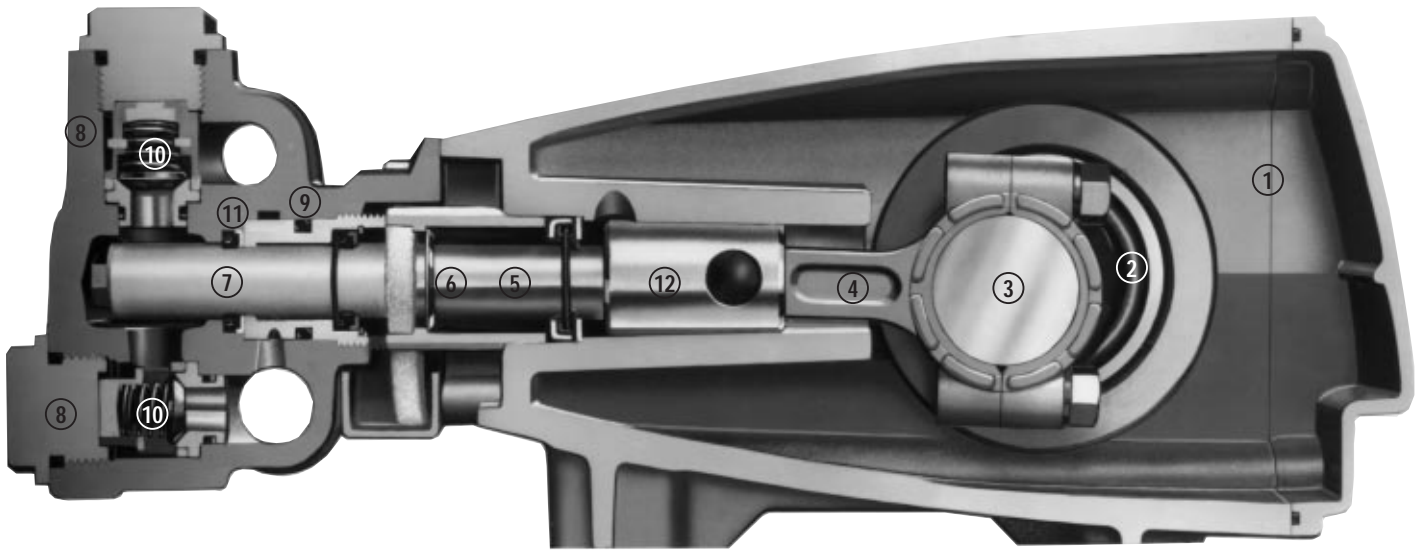

- 1 Die cast aluminum **crankcase** means high strength, lightweight, and excellent tolerance control.
- 2 Oversized crankshaft **bearings** provide extended bearing life and pump performance.
- 3 Chrome-moly **crankshaft** provides unmatched strength and surface hardness for long life.
- 4 Matched oversized **connecting rods** are made of Zamak, a material noted for strength and superior bearing quality.
- 5 The **plunger rods** are high tensile strength stainless steel with Zamak crossheads.
- 6 The stainless steel **slinger** provides back-up protection for the crankcase seal, keeping pumped fluids out of the crankcase.
- 7 Special concentric, high density, polished, graphite impregnated, solid ceramic **plungers** are abrasion resistant and result in extended seal life.
- 8 **Manifolds** are a high tensile strength forged brass for long term, continuous duty.
- 9 100% wet **seal** design adds to service life by allowing pumped fluids to cool and lubricate on both sides.
- 10 Stainless steel **valves, seats and springs** provide corrosion-resistance, positive seating and long life.
- 11 Specially formulated, CAT PUMP exclusive, **V-Packings** offer unmatched performance and seal life.
- 12 **Crossheads** are 360° supported for uncompromising alignment.

Products described hereon are covered by one or more of the following U.S. patents 3558244, 3652188, 3809508, 3920356, 3930756 and 5035580

Nov 1998 11843

World Headquarters

CAT PUMPS

1681 - 94th Lane N.E. Minneapolis, MN 55449-4324

Phone (612) 780-5440 — FAX (612) 780-2958

e-mail: sales@catpumps.com

www.catpumps.com

International Inquiries

FAX (612) 785-4443

e-mail: intlsales@catpumps.com



The Pump with "Nine Lives"

CAT PUMPS (U.K.) LTD.

1 Fleet Business Park, Sandy Lane, Church Crookham, Fleet

Hampshire GU13 0BF, England

Phone Fleet 44 1252-622031 — Fax 44 1252-626655

N.V. CAT PUMPS INTERNATIONAL S.A.

Heiveldekens 6A, 2550 Kontich, Belgium

Phone 32-3-450.71.50 — Fax 32-3-450.71.51

e-mail: cpi@catpumps.be

CAT PUMPS DEUTSCHLAND GmbH

Buchwiese 2, D-65510 Idstein, Germany

Phone 49 6126-93030 — Fax 49 6126-930333

e-mail: catpumps@t-online.de