



## 3K Series - Single Stage Stainless Steel End-Suction Centrifugal Pumps

### 3450 RPM Models

# 3K111-3K193

### 1725 RPM Models

# 3K361-3K393

#### FEATURES

- 304SS liquid-end construction offers corrosion resistance and increases operating life over typical cast iron models.
- Unique bulge formed components eliminates harsh radius and welds and provides greater efficiency and durability.
- Back pullout design permits easy repair of impeller and seal.
- High quality mechanical shaft seal and o-rings for a variety of standard or high temperature and chemical duty applications.
- Under casing foot mount and centerline discharge reduces misalignment and assures self-venting.
- Close coupled, motorized packages for compact and easy installation.

#### **⚠ CAUTIONS AND WARNINGS**

All High Pressure Systems require a primary pressure regulating device (i.e. regulator, unloader) and a secondary pressure relief device (i.e. pop-off valve, relief valve). Failure to install such relief devices could result in personal injury or damage to pump or property. CAT PUMPS does not assume any liability or responsibility for the operation of a customer's high pressure system.

Read all CAUTIONS and WARNINGS before commencing service or operation of any high pressure system. The CAUTIONS and WARNINGS are included in each service manual and with each Accessory Data sheet. CAUTIONS and WARNINGS can also be viewed online at [www.catpumps.com/cautions-warnings](http://www.catpumps.com/cautions-warnings) or can be requested directly from CAT PUMPS.

#### **WARRANTY**

View the Limited Warranty on-line at [www.catpumps.com/warranty](http://www.catpumps.com/warranty).

#### SPECIFICATIONS

	U.S. Measure
Flow Range .....	5.5 to 90.0 gpm
Pressure Range .....	10 to 63 psi / 23 to 145 Ft. Head
Max. Working Pressure .....	125 psi
Min. Inlet Pressure to Prime .....	Flooded
RPM .....	1725 or 3450 rpm
Inlet Fitting	3K111-3K163, 3K361-3K363 ..... 1.25" NPT
	3K171-3K193, 3K391-3K393 ..... 1.5" NPT
Discharge Fitting	All Models ..... 1" NPT
Horsepower Range .....	1/3 to 3 HP
Motor Options	56J Frame TEFC Class F
	1/3-1/2HP ..... 115/208-230V, 1 PH, 60 HZ
	3/4-1.0-1.5HP ..... 115/230V, 1 PH, 60 HZ
	2.0HP ..... 230V, 1 PH, 60 HZ
	1/3 to 3.0HP ..... 208-230/460V, 3 PH, 60 HZ
Cycle .....	60 HZ
Max. Temperature	Continuous ..... *160°F
Weight (Pump Only)	3K111, 3K141, 3K171 ..... 8.4 lbs.
	3K121, 3K151, 3K181 ..... 8.7 lbs.
	3K131, 3K161, 3K191, 3K361, 3K391 ..... 9.0 lbs.
Dimensions	Pump Only (see chart) ..... 9.63 x 8.18 x 4.52"

\*Contact Cat Pumps for applications above 160°F.

# SELECTION CHART - 1725 RPM

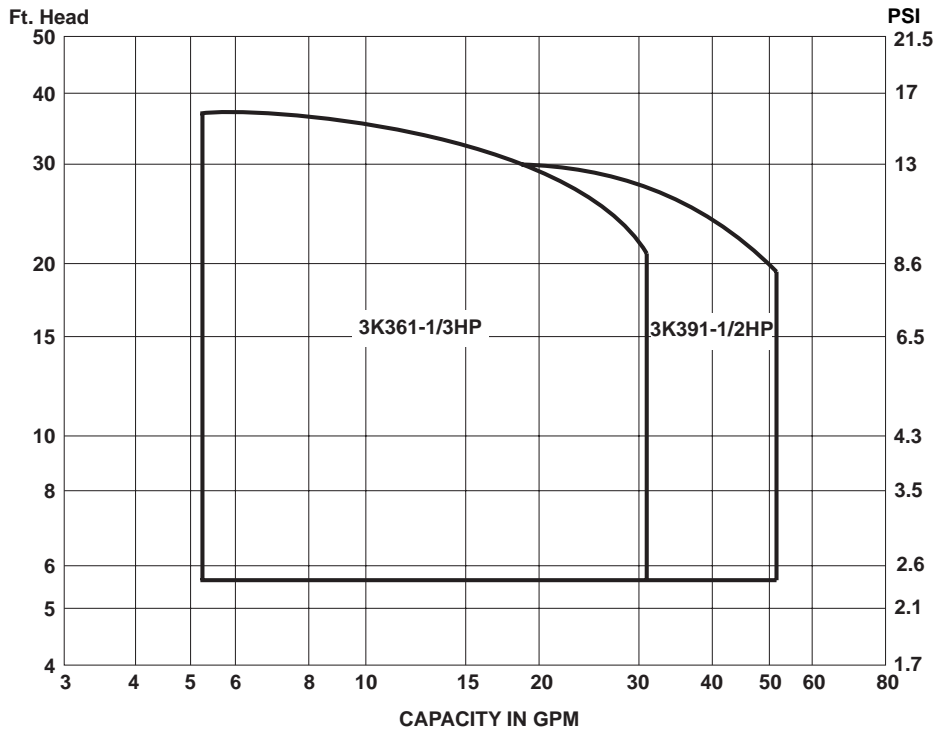

Note: See motorized pump unit codes chart to configure pump and motor.

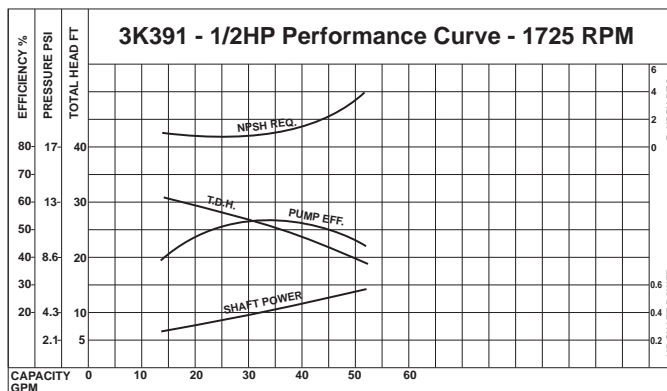
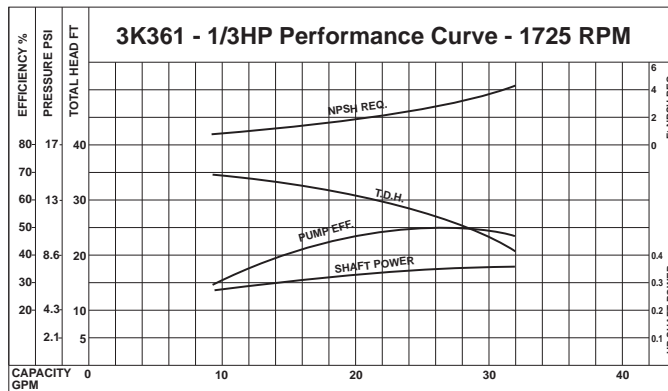

All calculations based upon water @ Spec. Gravity of 1.00

# SELECTION CHART - 3450 RPM

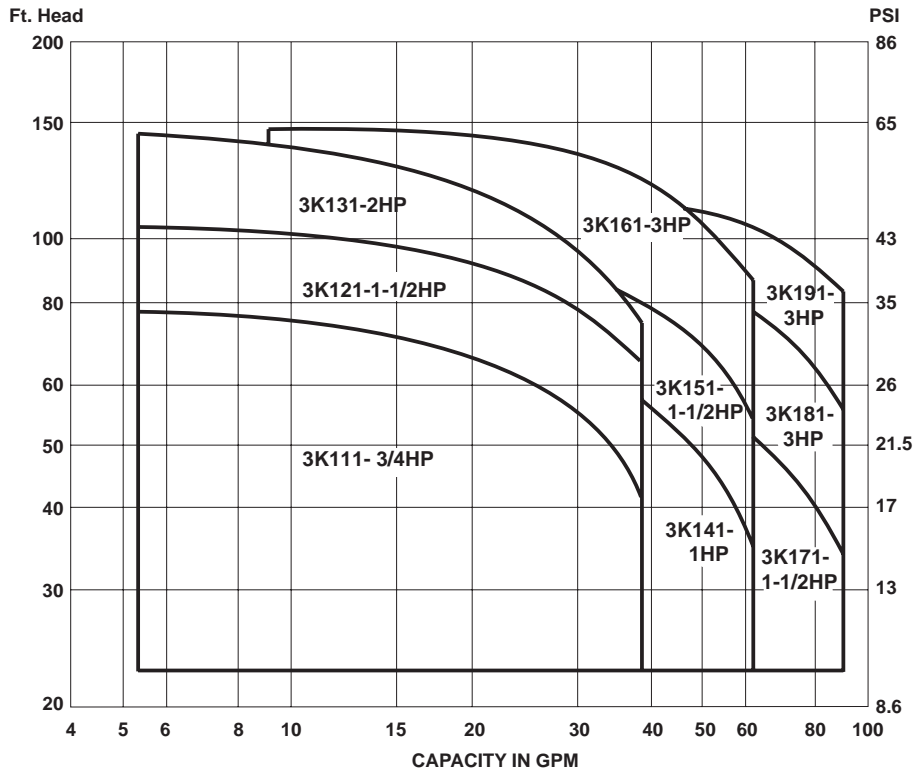

Note: See motorized pump unit codes chart to configure pump and motor.

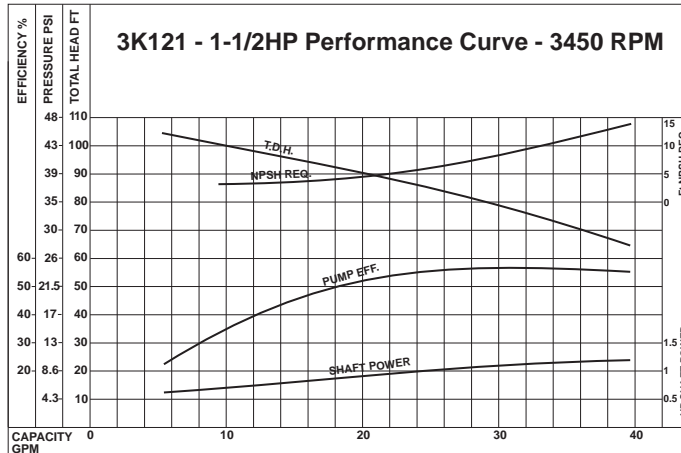
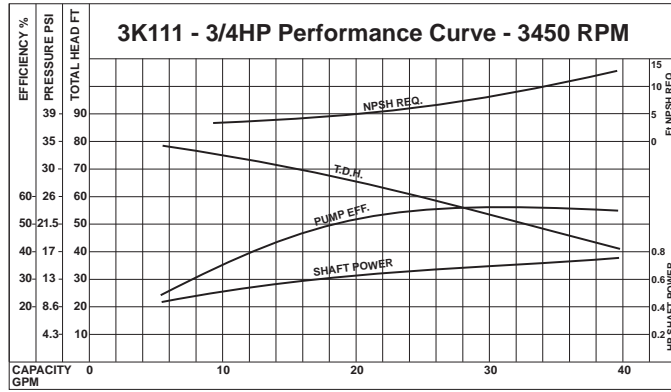

All calculations based upon water @ Spec. Gravity of 1.00

# SELECTION CHART - 3450 RPM CONTINUED

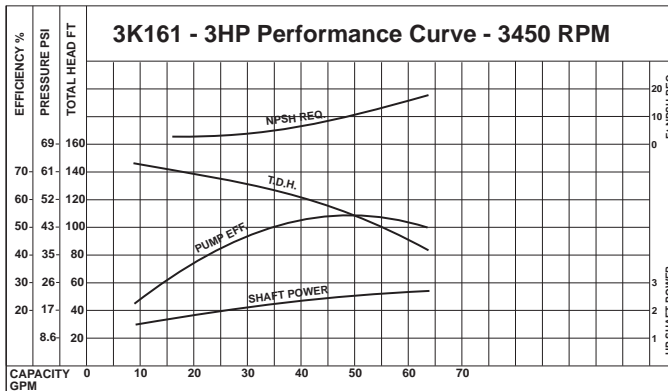
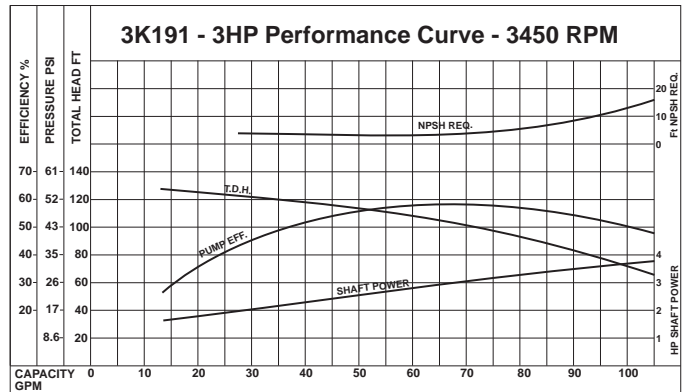
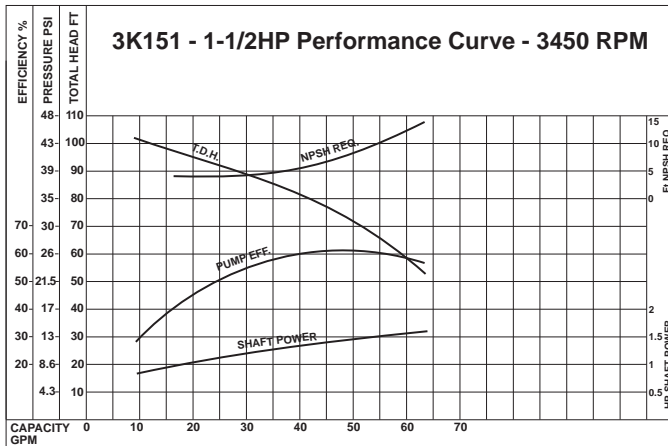
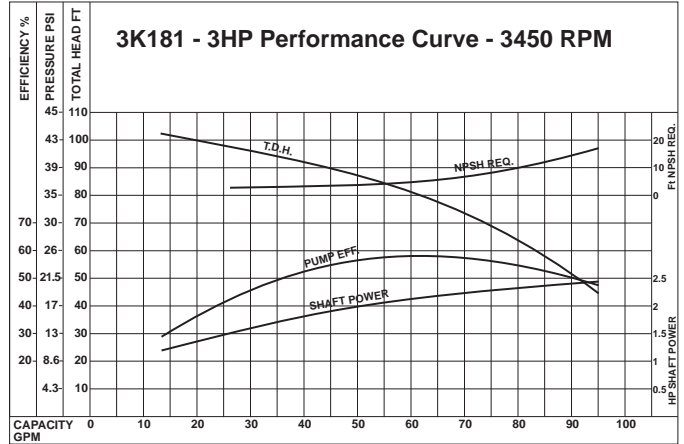
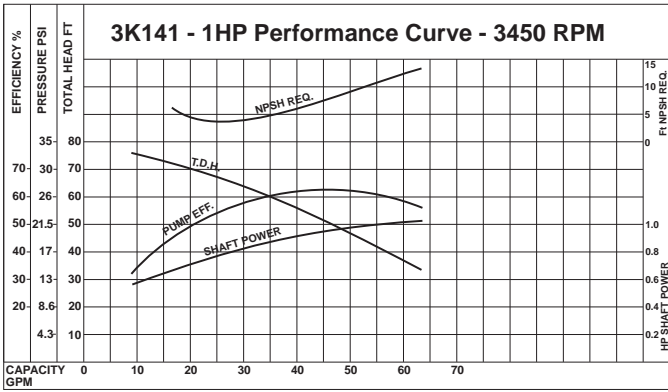
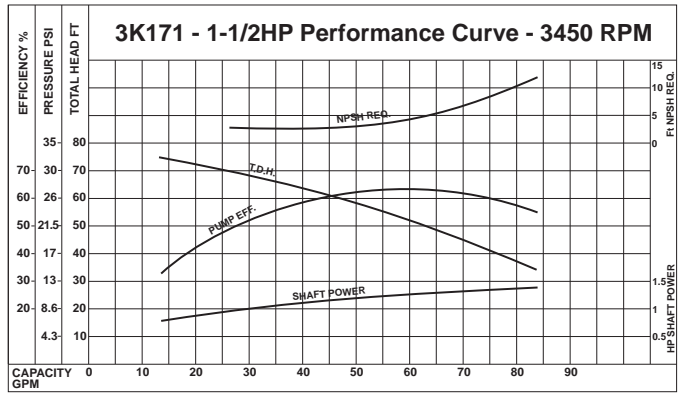
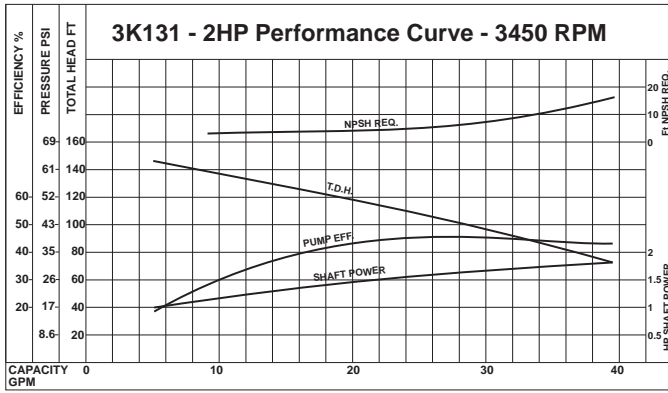

## MOTORIZED PUMP UNIT CODES

3	K	1	7	1	W	T	3	<b>Pump Number</b> 1 = NCC Standard Seal Assy (Carbon/Ceramic/Buna) <b>Standard Service</b> 2 = FCC Alternate Seal Assy (Carbon/Ceramic/FPM) <b>Mild Chemical</b> 3 = HCC Alternate Seal Assy (Carbon/Ni/Resist/FPM) <b>High Temperature</b> 4 = FSC Alternate Seal Assy (FPM/Silicon Carbide) <b>Strong Chemical</b>										
3	K	1	7	1	W	T	3	<b>Motor Brand</b> M = Magnetek B = Baldor C = Italian W = Weg										
3	K	1	7	1	W	T	3	<b>Motor Enclosure</b> T = TEFC D = ODP										
3	K	1	7	1	W	T	3	<b>Motor Phase And Voltage</b> <table style="width: 100%; border: none;"> <tr> <td style="width: 50%;">Single Phase</td> <td style="width: 50%;">Three Phase</td> </tr> <tr> <td>0 = 115/208-230V</td> <td>3 = 208-230/460V</td> </tr> <tr> <td>1 = 115/230V</td> <td>4 = 230/460V</td> </tr> <tr> <td>2 = 230V</td> <td>5 = 575V</td> </tr> <tr> <td></td> <td>6 = 380V</td> </tr> </table>	Single Phase	Three Phase	0 = 115/208-230V	3 = 208-230/460V	1 = 115/230V	4 = 230/460V	2 = 230V	5 = 575V		6 = 380V
Single Phase	Three Phase																	
0 = 115/208-230V	3 = 208-230/460V																	
1 = 115/230V	4 = 230/460V																	
2 = 230V	5 = 575V																	
	6 = 380V																	

### 1725 RPM MOTORIZED PUMP UNIT

Pump Kit Model	Motor P/N	Motor wt (lbs)	MPU		Motor		MPU Lgth (in)	MPU wt (lbs)
			Lgth (in)	wt (lbs)	P/N	wt (lbs)		
3K361	899117	21.00	13.82	30.00	899119	21.00	13.81	30.00
3K391					899121	22.00	13.81	31.00

### 3450 RPM MOTORIZED PUMP UNIT

3K111	899170	30.00	14.71	38.40	899171	25.00	14.71	33.40
3K121	899174	35.00	15.83	43.70	899175	31.00	14.71	39.70
3K131	899176	38.00	15.83	47.00	899177	35.00	15.08	44.00
3K141	899169	33.00	15.08	41.40	899173	28.00	14.71	36.40
3K151	899174	35.00	15.83	43.70	899175	31.00	14.71	39.70
3K161					899178	40.00	16.33	49.00
3K171	899174	35.00	15.83	43.40	899175	31.00	14.71	39.40
3K181					899178	40.00	16.33	48.70
3K191					899178	40.00	16.33	49.00

## DIMENSIONAL

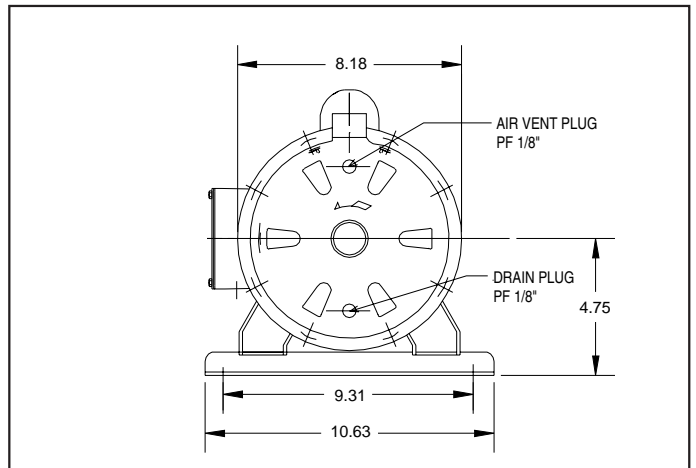
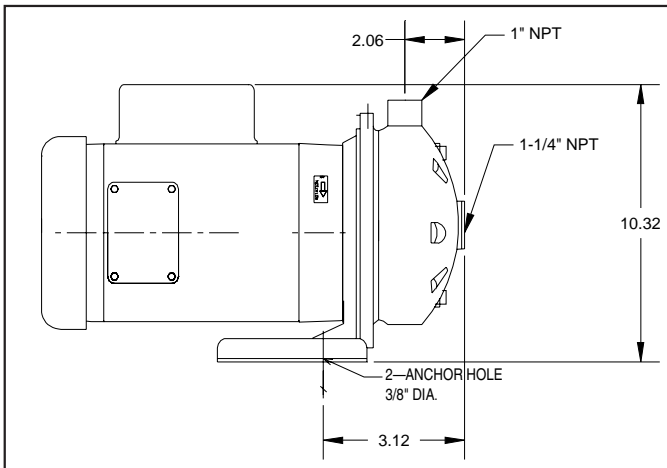

## PUMP KIT PARTS LIST

ITEM	PART NUMBER	MATL	DESCRIPTION	QTY
900	899271	S	Casing w/Casing Ring (899290), 3K111-3K133	1
	899272	S	Casing, 3K141-3K153	1
	899273	S	Casing, 3K161-3K163, 3K361-363	1
	899274	S	Casing, 3K171-3K193, 3K391-193	1
901	899275	S	Cover, Casing	1
902	899279	AL	Bracket	1
904	899200	S	Impeller, 3K111 (4.50")	1
	899201	S	Impeller, 3K121 (5.19")	1
	899202	S	Impeller, 3K131 (6.19")	1
	899203	S	Impeller, 3K141 (4.50")	1
	899204	S	Impeller, 3K151 (5.19")	1
	899205	S	Impeller, 3K161, 3K361 (6.19")	1
	899206	S	Impeller, 3K171 (4.50")	1
	899207	S	Impeller, 3K181 (5.19")	1
	899208	S	Impeller, 3K191, 3K391 (5.69")	1
905	899280	S	Nut, Impeller (7/16-20)	1
907	899001	NCC	Seal, Shaft Assy (Standard)	1
	899002	FCC	Seal, Shaft Assy (Mild Chemical)	1
	899003	HCC	Seal, Shaft Assy (High Temp)	1
	899008	FSC	Seal, Shaft Assy (Strong Chemical)	1
908	899250	FPM	O-Ring, Case	1
909	—	S	Screw, Socket (M6x16)	8
910	—	S	Screw, Hex (M8x16)	2
911	—	S	Screw, Socket (3/8-16x1")	4
912	—	S	Screw, Socket (M8x45)	1
913	—	S	Nut, Hex (M8)	1
914	—	S	Lockwasher, Toothed (M6)	8
915	—	AL	Washer, Plug	2
916	—	S	Lockwasher, Toothed (M8)	4
919	899252	FPM	O-Ring, Plug (Not Shown)	2
921	899281	STL	Base	1
922	—	S	Plug	2
938	899283	—	Mount, Bolt Assy	1
			<i>(Incls: 905, 909, 910, 911, 912, 913, 914, 916)</i>	
939	899282	—	Kit, Plug <i>(Incls: 915, 919, 922)</i>	1

*Italics are optional items.*

MATERIAL CODES (Not Part of Part Number)

AL=Aluminum

FCC=Carbon/Ceramic/FPM

FPM=Fluorocarbon

FSC=FPM w/Silicon Carbide

HCC=Carbon/Ni/Resist/FPM

NCC=Carbon/Ceramic/Buna

S=304SS

STL=Steel

# EXPLODED VIEW

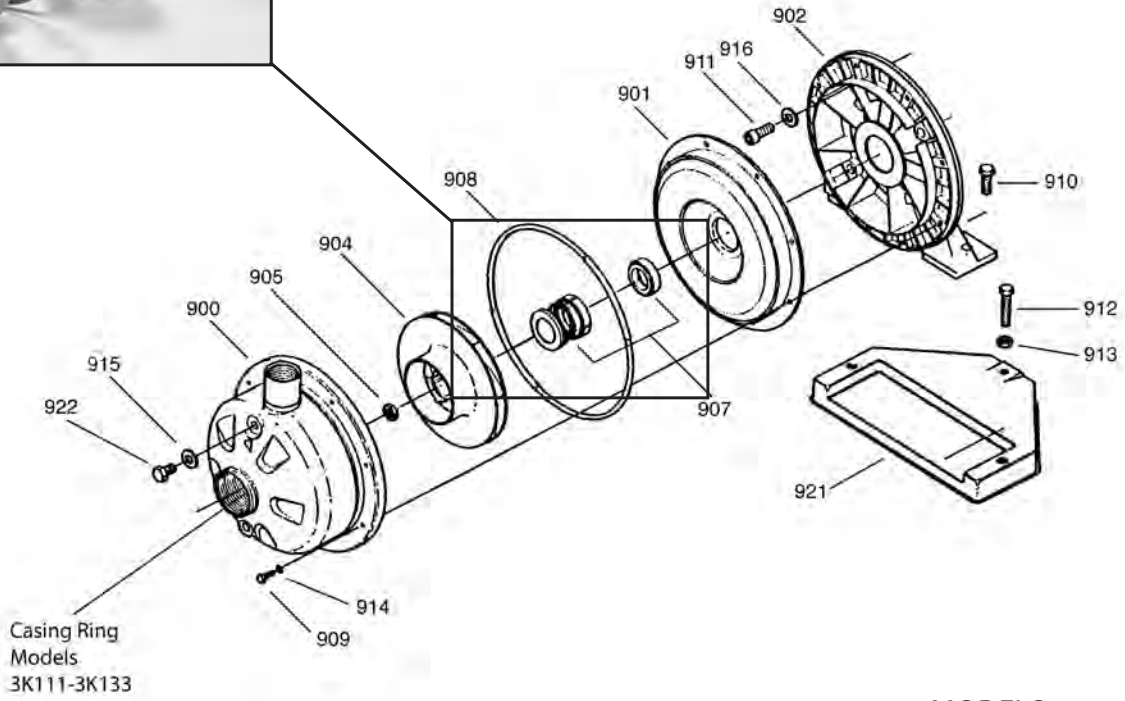

MODELS  
3450 RPM - 3K111-3K193  
1725 RPM - 3K361-3K393  
April 2012

# GENERAL SAFETY AND OPERATION

**SELECTION:** Review the Selection Chart to find the performance range and pump model suited to your application requirements. Then review the Performance Curve Chart to verify the most efficient performance and inlet conditions required.

**INSTALLATION:** These pumps may be installed in either a horizontal (most common) or vertical position (as installation requires). The following criteria should be considered to assure optimum performance:

- Proper alignment of plumbing
- Adequate line size to prevent starvation
- Rigid metal or plastic pipe or reinforced flexible plumbing to prevent collapsing lines
- Properly sealed connections to prevent air leaks
- Good filtration of the liquid to avoid abrasives and solids
- Foot valve may need to be installed at the inlet

**OPERATION:** The pump comes with a standard seal for fresh water or non harsh liquids. Excessive pH, high viscosity and abrasives will affect the life and performance of the pump. Special shaft seals are available for high temperature or chemical duty applications. Check with Cat Pumps for high viscosity liquids. Make certain there is sufficient liquid supply to the pump before starting operation.

**MAINTENANCE:** This is a low maintenance pump. The shaft seal and impeller are the primary service items. These can be easily replaced.

1. Remove the 8 hex screws and slide the casing from the cover.
2. Remove the impeller nut and unthread the impeller.
3. Carefully pry the casing cover away from the bracket.
4. Lay the cover on the work surface (large diameter up) and press out the shaft seal.
5. Turn the cover over on the work surface (small diameter up) and press the **back half** (stationary half) of the new shaft seal into position until completely seated in the chamber with the **elastomer side down**.

NOTE: If seal installation is tight, carefully apply a small amount of lubricant to the **outer edge** (non-chlorine dish soap). DO NOT USE OIL OR GREASE.

### CAUTION

Exercise care when handling the shaft seal. It can be easily contaminated by improper handling and will not properly seal. Use the paper cover to press the seal into position and toss the cover when done.

6. Align the cover with the holes on the bracket and press into position.
7. Slide the **front half** of the seal (rotating half) onto the shaft with the **elastomer side out** (carbon/ceramic surfaces mating). Then slide the seal spring and washer onto the shaft.
8. Hold the seal spring in place and thread the impeller into position until completely seated.

NOTE: Use a screwdriver to hold the motor shaft stationary.

9. Install the impeller hex nut onto the shaft and torque per chart. Rotate the impeller to assure proper alignment before installing the cover.

NOTE: Apply Loctite® 609 to the impeller nut before installing.

10. Place the new O-Ring over the casing cover. Exercise caution not to cut or twist the O-Ring during installation.
11. Replace the casing cover. Rotate to desired discharge port position and align holes. Replace 8 lockwashers and socket screws and torque per chart.

### TORQUE CHART

	Size	Torque		
		ft. lbs.	in. lbs.	Nm
<b>Impeller Nut</b>	7/16-20	12-18	144-215	16-24
<b>Pump Casing</b> (To Motor Bracket)	M6 x 18 Hex Head Cap Screw	3.4	41	4.6
<b>Motor Bracket</b> (To Motor)	3/8" -16 x 1" Socket Head Bolt 3/8" Ext. Tooth Lockwasher	6.0	96	10.8
<b>Motor Stand/Base</b> (To Motor Bracket)	M8 x 16 Hex Head Cap Screw	4.0	48	5.4
<b>Motor Stand Support</b>	M6 x 30 Hex Head Cap Screw M8 Hex Nut	No Requirements (Adjust to Support Motor/Variable)		

### TROUBLESHOOTING

PROBLEM	SOLUTION
• No flow or low flow	• Check rotation of pump • Check liquid supply to pump
• Leaking	• Replace shaft seal • Check case cover o-ring
• Noise	• Check liquid supply to pump • Check viscosity of liquid • Review NPSH requirements
• Vibration	• Secure plumbing to and from pump • Check impeller and replace as needed

### WARRANTY

**This pump is warranted for one year from date of purchase.**

Improper installation and use will void the warranty.  
Tampering with the impeller or seals will void the warranty.

Loctite is a registered trademark of the Henkel Corporation.



#### CAT PUMPS

1681 - 94TH LANE N.E. MINNEAPOLIS, MN 55449-4324  
PHONE (763) 780-5440 — FAX (763) 780-2958  
e-mail: techsupport@catpumps.com  
www.catpumps.com