



3K Series - Single Stage Stainless Steel End-Suction Centrifugal Pumps

3450 RPM Models

3K111-3K193

1725 RPM Models

3K361-3K393

FEATURES

- 304SSL liquid-end construction offers corrosion resistance and increases operating life over typical cast iron models.
- Unique bulge formed components eliminates harsh radius and welds and provides greater efficiency and durability.
- Back pullout design permits easy repair of impeller and seal.
- High quality mechanical shaft seal and o-rings for a variety of standard or high temperature and chemical duty applications.
- Under casing foot mount and centerline discharge reduces misalignment and assures self-venting.
- Close coupled, motorized packages for compact and easy installation.

SPECIFICATIONS

	U.S. Measure
Flow Range5.5 to 90.0 GPM
Pressure Range10 to 63 PSI
23 to 145 Ft. Head
Max. Working Pressure125 PSI
Min. Inlet Pressure to PrimeFlooded
RPM1725 or 3450 RPM
Inlet Fitting	3K111-3K163, 3K361-3K3631.25" NPT
	3K171-3K193, 3K391-3K3931.5" NPT
Discharge Fitting	All Models1" NPT
Horsepower Range1/3 to 3 HP
Motor Options	56J Frame TEFC Class F
	1/3-1/2HP115/208-230V, 1 PH, 60 HZ
	3/4-1.0-1.5HP115/230V, 1 PH, 60 HZ
	2.0HP230V, 1 PH, 60 HZ
	1/3 to 3.0HP208-230/460V, 3 PH, 60 HZ
Cycle60 HZ
Max. Temperature	Continuous*160°F
Weight (Pump Only)	3K111, 3K141, 3K1718.4 Lbs.
	3K121, 3K151, 3K1818.7 Lbs.
	3K131, 3K161, 3K191, 3K361, 3K3919.0 Lbs.
Dimensions	Pump Only (see chart)9.63x8.18x4.52"

*Contact CAT PUMPS for applications above 160°F.

“Customer confidence is our greatest asset”

EXPLODED VIEW

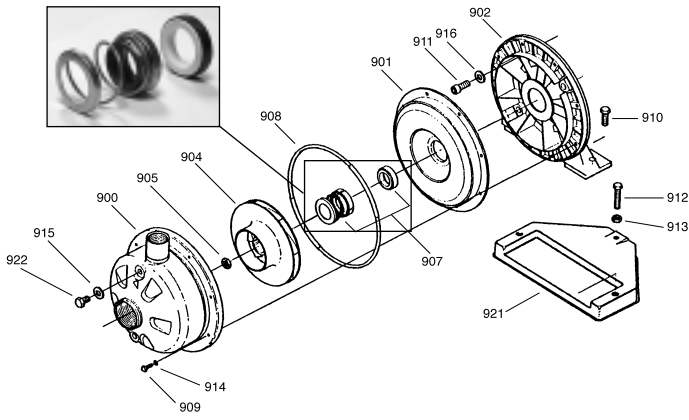

DIMENSIONAL

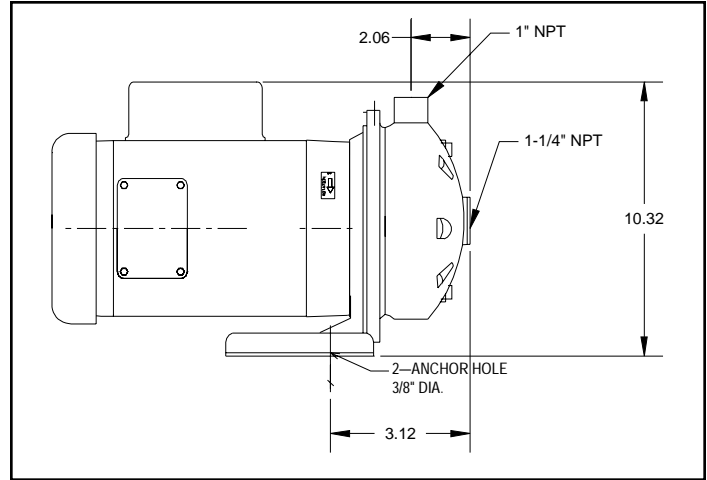

PARTS LIST

ITEM	P/N	MATL	DESCRIPTION	QTY
900	—	S	Casing, 3K111-3K133	1
	—	S	Casing, 3K141-3K153	1
	—	S	Casing, 3K161-3K163, 3K361-363	1
	—	S	Casing, 3K171-3K193, 3K391-193	1
901	—	S	Cover, Casing	1
902	—	AL	Bracket	1
904	899200	S	Impeller, 3K111 (4.50")	1
	899201	S	Impeller, 3K121 (5.19")	1
	899202	S	Impeller, 3K131 (6.19")	1
	899203	S	Impeller, 3K141 (4.50")	1
	899204	S	Impeller, 3K151 (5.19")	1
	899205	S	Impeller, 3K161, 3K361 (6.19")	1
	899206	S	Impeller, 3K171 (4.50")	1
	899207	S	Impeller, 3K181 (5.19")	1
	899208	S	Impeller, 3K191, 3K391 (5.69")	1
905	—	S	Nut, Impeller (7/16-20)	1
907	899001	NCC	Seal, Shaft Assy (Standard)	1
	899002	FCC	Seal, Shaft Assy (Mild Chemical)	1
	899003	HCC	Seal, Shaft Assy (High Temp)	1
908	899250	FPM	O-Ring, Case	1
909	—	S	Screw, Socket (M6x16)	8
910	—	S	Screw, Hex (M8x16)	2
911	—	S	Screw, Socket (3/8-16x1")	4
912	—	S	Screw, Socket M8x45	1
913	—	S	Nut, Hex (M8)	1
914	—	S	Lockwasher, Toothed (M6)	8
915	—	AL	Washer, Case	2
916	—	S	Lockwasher, Toothed (M8)	4
921	—	STL	Base	1
922	—	S	Plug	2

Italics are optional items.

MATERIAL CODES (Not Part of Part Number):

AL=Aluminum FCC=Carbon/Ceramic/Viton®

HCC=Carbon/Ni/Resist/Viton® FPM=Fluorocarbon (Viton®)

NCC=Carbon/Ceramic/Buna S=304SS STL=Steel

PUMP CODES:

Last digit of Pump Kit is Seal Assembly type

- 1 = NCC Standard Seal Assy (Carbon/Ceramic/Buna) **Standard Service**
- 2 = FCC Alternate Seal Assy (Carbon/Ceramic/Viton®) **Mild Chemical**
- 3 = HCC Alternate Seal Assy (Carbon/Ni/Resist/Viton®) **High Temperature**

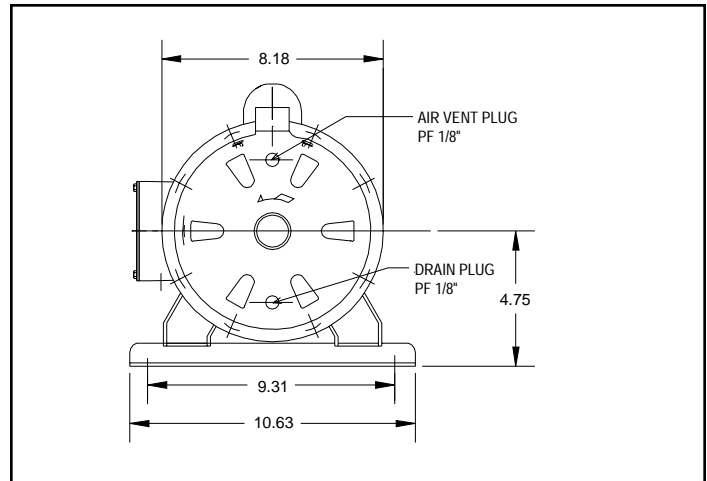

1725 RPM MPU								
Pump Model	Motor P/N	Motor wt (lbs)	MPU Lgth (in)	MPU wt (lbs)	Motor P/N	Motor wt (lbs)	MPU Lgth (in)	MPU wt (lbs)
	1PH	1PH	1PH	1PH	3PH	3PH	3PH	3PH
3K361	899117	21.00	13.82	30.00	899119	21.00	13.81	30.00
3K391	899118	26.00	14.82	35.00	899121	22.00	13.81	31.00
3450 RPM MPU								
3K111	899122	30.00	14.71	38.40	899126	26.00	14.71	34.40
3K121	899124	37.00	15.83	45.70	899128	31.00	14.71	39.70
3K131	899125	38.00	15.83	47.00	899129	35.00	15.08	44.00
3K141	899123	33.00	15.08	41.40	899127	28.00	14.71	36.40
3K151	899124	37.00	15.83	45.70	899128	31.00	14.71	39.70
3K161					899130	40.00	16.33	49.00
3K171	899124	37.00	15.83	45.40	899128	31.00	14.71	39.40
3K181					899130	40.00	16.33	48.70
3K191					899130	40.00	16.33	49.00

MPU CODES:

Last digit of MPU is Motor Phase and Voltage

- Single Phase
- 0 = 115/208-230V
- 1 = 115/230V
- 2 = 230V
- Three Phase
- 3 = 208-230/460V
- 4 = 230/460V
- 5 = 575V
- 6 = 380V

SELECTION CHART - 1725 RPM

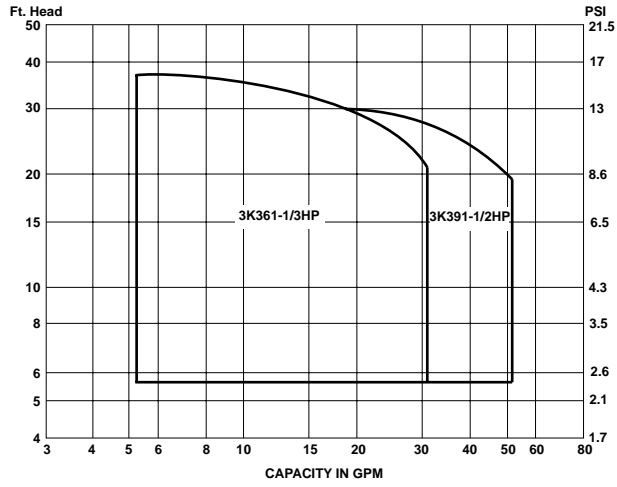

SELECTION CHART - 3450 RPM

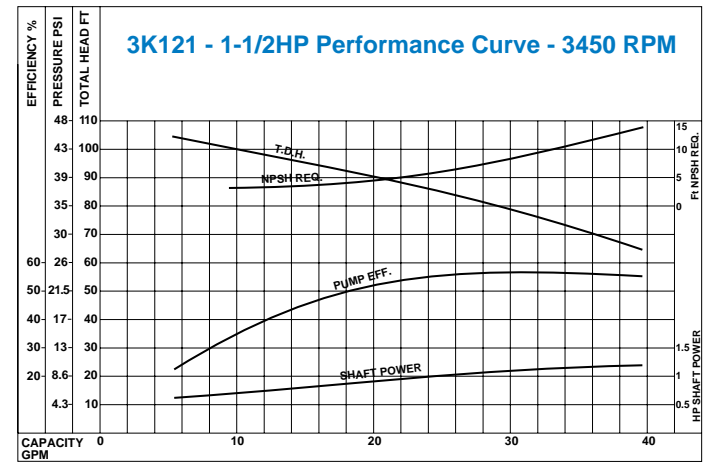
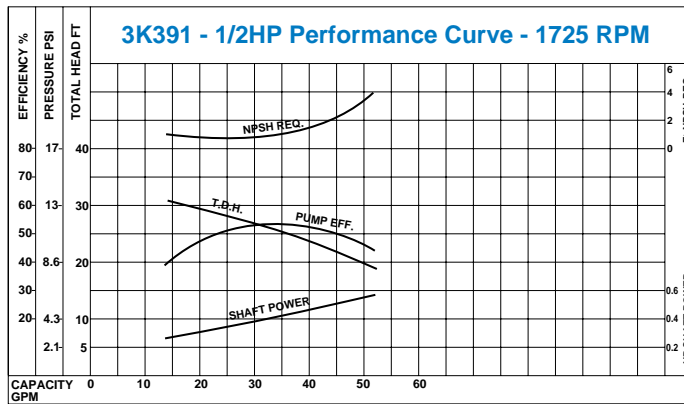
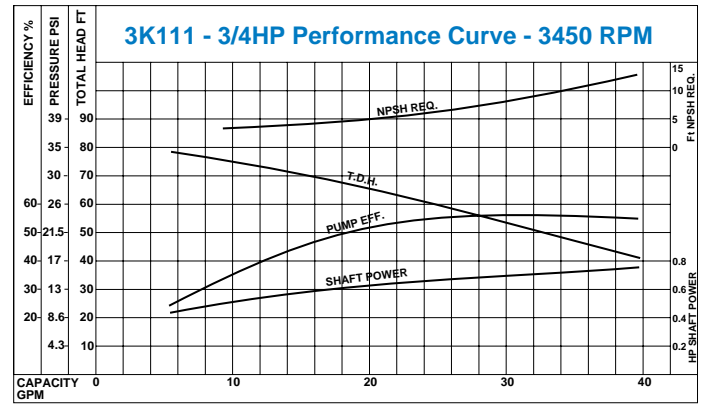
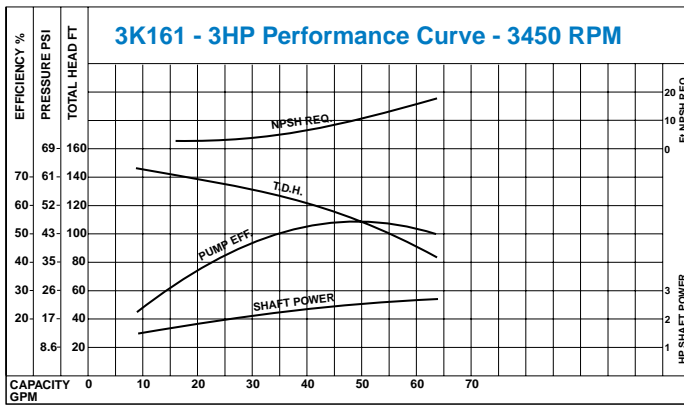
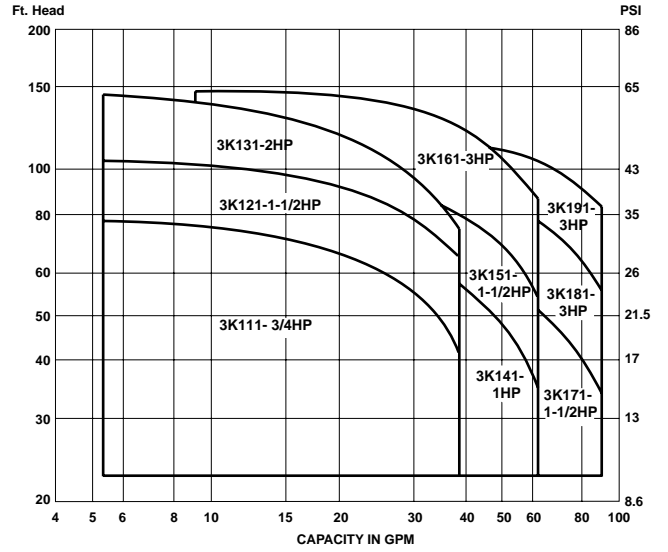

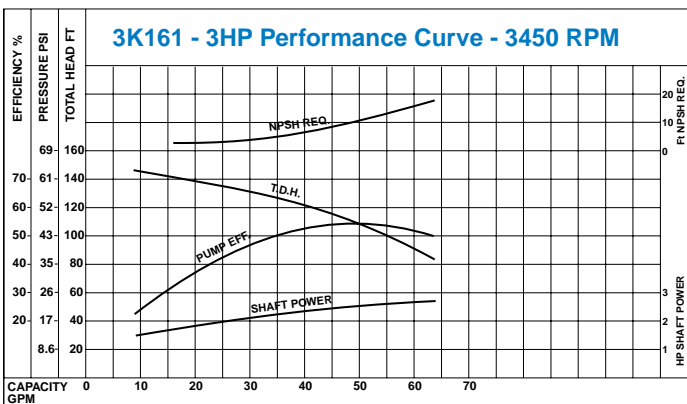
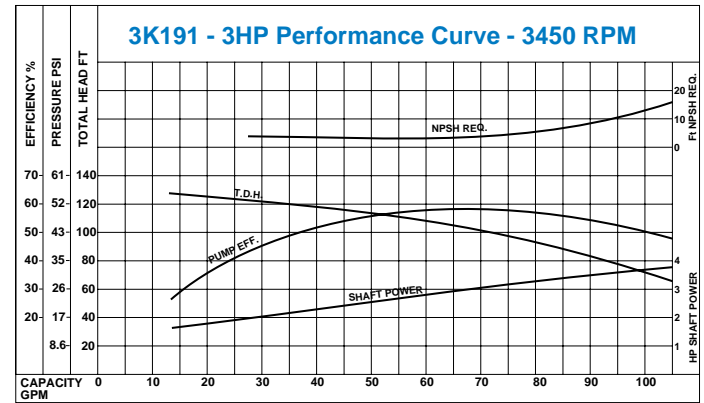
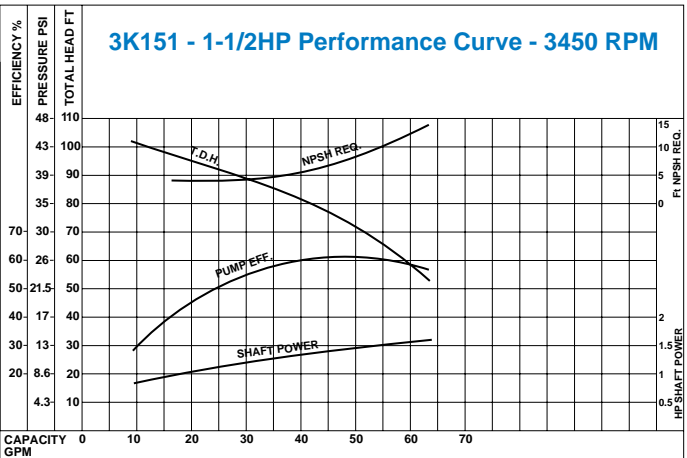
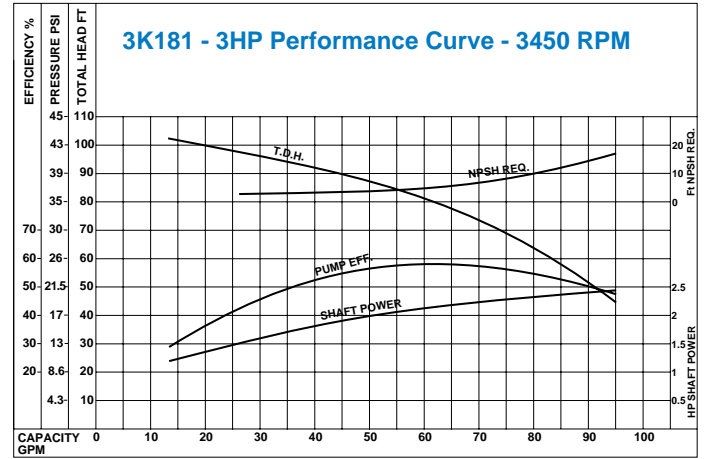
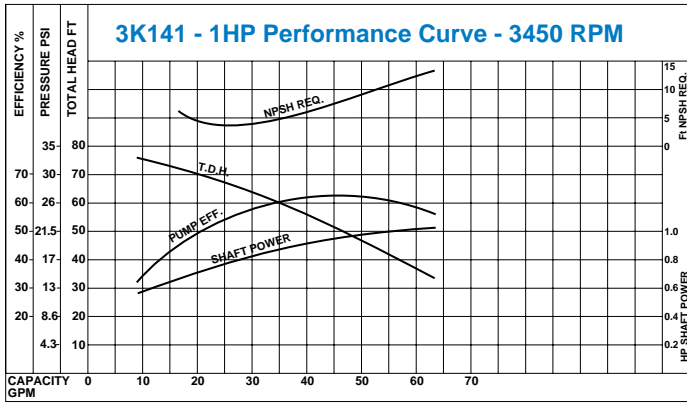
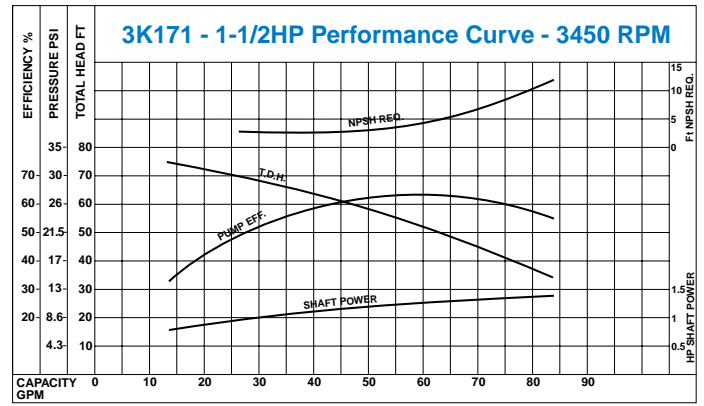
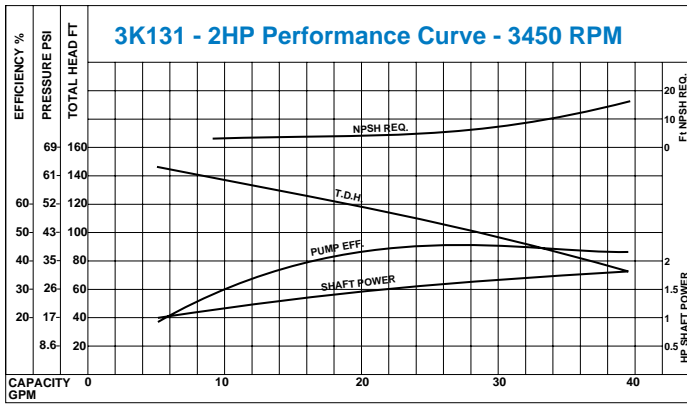

GENERAL SAFETY AND OPERATION

SELECTION: Review the Selection Chart to find the performance range and pump model suited to your application requirements. Then review the Performance Curve Chart to verify the most efficient performance and inlet conditions required.

INSTALLATION: These pumps may be installed in either a horizontal (most common) or vertical position (as installation requires). The following criteria should be considered to assure optimum performance:

- Proper alignment of plumbing
- Adequate line size to prevent starvation
- Rigid metal or plastic pipe or reinforced flexible plumbing to prevent collapsing lines
- Properly sealed connections to prevent air leaks
- Good filtration of the liquid to avoid abrasives and solids
- Foot valve may need to be installed at the inlet

OPERATION: The pump comes with a standard seal for fresh water or non harsh liquids. Excessive pH, high viscosity and abrasives will affect the life and performance of the pump. Special shaft seals are available for high temperature or chemical duty applications. Check with CAT PUMPS for high viscosity liquids. Make certain there is sufficient liquid supply to the pump before starting operation.

MAINTENANCE: This is a low maintenance pump. The shaft seal and impeller are the primary service items. These can be easily replaced.

1. Remove the 8 hex screws and slide the casing from the cover.
2. Remove the impeller nut and unthread the impeller.
3. Carefully pry the casing cover away from the bracket.
4. Lay the cover on the work surface (large diameter up) and press out the shaft seal.
5. Turn the cover over on the work surface (small diameter up) and press the **back half** (stationary half) of the new shaft seal into position until completely seated in the chamber with the **elastomer side down**.

CAUTION

Exercise care when handling the shaft seal. It can be easily contaminated by improper handling and will not properly seal. Use the paper cover to press the seal into position and toss the cover when done.

NOTE: If seal installation is tight, carefully apply a small amount of lubricant to the **outer edge** (non-chlorine dish soap). DO NOT USE OIL OR GREASE.

6. Align the cover with the holes on the bracket and press into position.

7. Slide the **front half** of the seal (rotating half) onto the shaft with the **elastomer side out** (carbon/ceramic surfaces mating). Then slide the seal spring and washer onto the shaft.
8. Hold the seal spring in place and thread the impeller into position until completely seated.
NOTE: Use a screwdriver to hold the motor shaft stationary.
9. Install the impeller hex nut onto the shaft and torque per chart. Rotate the impeller to assure proper alignment before installing the cover.
NOTE: Apply loctite to the impeller nut before installing.
10. Place the new O-Ring over the casing cover. Exercise caution not to cut or twist the O-Ring during installation.
11. Replace the casing cover. Rotate to desired discharge port position and align holes. Replace 8 lockwashers and socket screws and torque per chart.

TORQUE CHART

	Size	Torque	
		ft. lbs.	in. lbs. Nm
Impeller Nut	7/16-20	12-18	144-215 16-24
Pump Casing (To Motor Bracket)	M6 x 18 Hex Head Cap Screw	3.4	41 4.6
Motor Bracket (To Motor)	3/8"-16 x 3/4" Socket Head Bolt 3/8" Ext. Tooth Lockwasher	6.0	96 10.8
Motor Stand/Base (To Motor Bracket)	M8 x 16 Hex Head Cap Screw	4.0	48 5.4
Motor Stand Support	M6 x 30 Hex Head Cap Screw M8 Hex Nut	No Requirements (Adjust to Support Motor/Variable)	

TROUBLESHOOTING

PROBLEM	SOLUTION
• No flow or low flow	• Check rotation of pump • Check liquid supply to pump
• Leaking	• Replace shaft seal • Check case cover o-ring
• Noise	• Check liquid supply to pump • Check viscosity of liquid • Review NPSH requirements
• Vibration	• Secure plumbing to and from pump • Check impeller and replace as needed

WARRANTY

This pump is warranted for one year from date of purchase.
Improper installation and use will void the warranty.
Tampering with the impeller or seals will void the warranty.

Products described hereon are covered by one or more of the following U.S. patents 3558244, 3652188, 3809508, 3920356, 3930756 and 5035580

World Headquarters

CAT PUMPS

1681 - 94th Lane N.E. Minneapolis, MN 55449-4324

Phone (763) 780-5440 — FAX (763) 780-2958

e-mail: techsupport@catpumps.com

www.catpumps.com

International Inquiries

FAX (763) 785-4329

e-mail: intlsales@catpumps.com



The Pumps with Nine Lives

CAT PUMPS (U.K.) LTD.

1 Fleet Business Park, Sandy Lane, Church Crookham, Fleet

Hampshire GU52 8BF, England

Phone Fleet 44 1252-622031 — Fax 44 1252-626655

e-mail: sales@catpumps.co.uk

N.V. CAT PUMPS INTERNATIONAL S.A.

Heiveldekens 6A, 2550 Kontich, Belgium

Phone 32-3-450.71.50 — Fax 32-3-450.71.51

e-mail: cpi@catpumps.be www.catpumps.be

CAT PUMPS DEUTSCHLAND GmbH

Buchwiese 2, D-65510 Idstein, Germany

Phone 49 6126-9303 0 — Fax 49 6126-9303 33

e-mail: catpumps@t-online.de www.catpumps.de