



Model 3CP1221.44101 Shown
(Rails and shaft protector sold separately)

FEATURES

- Designed for continuous-duty performance for triethylene glycol (TEG) gas dehydration where low life cycle costs are a must.
- Field tested, high pressure triplex pump configured for TEG temperatures up to 240° F (116° C).
- Positive displacement technology for optimum energy efficiency.
- Compact footprint enhances direct-drive gearbox and bell housing drives.

COMMON SPECIFICATIONS

Inlet Pressure Range.....	Flooded to 70 psi	(Flooded to 4.9 bar)
Bore.....	0.709"	(18 mm)
Crankcase Capacity.....	10 oz.	(0.3 l)
Maximum Liquid Temperature	240°F	(116°C)
Inlet Ports (2).....	1/2" NPTF	(1/2" NPTF)
Discharge Ports (2).....	3/8" NPTF	(3/8" NPTF)
Pulley Mounting	Either Side	(Either Side)
Shaft Diameter	0.650"	(16.5 mm)
Weight.....	14.84 lbs.	(6.7 kg)
Dimensions.....	9.91 x 8.78 x 6.75"	(252 x 223 x 171 mm)

⚠ CAUTIONS AND WARNINGS

All High Pressure Systems require a primary pressure regulating device (i.e. regulator, unloader) and a secondary pressure relief device (i.e. pop-off valve, relief valve). Failure to install such relief devices could result in personal injury or damage to pump or property. CAT PUMPS does not assume any liability or responsibility for the operation of a customer's high pressure system.

Read all CAUTIONS and WARNINGS before commencing service or operation of any high pressure system. The CAUTIONS and WARNINGS are included in each service manual and with each Accessory Data sheet. CAUTIONS and WARNINGS can also be viewed online at www.catpumps.com/cautions-warnings or can be requested directly from CAT PUMPS.

WARRANTY

View the Limited Warranty on-line at www.catpumps.com/warranty.

3CP Stainless Steel Plunger Pump Triethylene Glycol (TEG) Dehydration

Models **3CP1221.44101**
3CP1231.44101
3CP1241.44101

SPECIFICATIONS

U.S. Measure

Metric Measure

MODEL 3CP1221.44101 Direct Drive

Flow.....	4.2 gpm	(16 lpm)
Pressure Range.....	100 to 2000 psi	(7 to 140 bar)
RPM.....	1725 rpm	(1725 rpm)
Stroke.....	0.500"	(12.7 mm)

MODEL 3CP1231.44101 Direct Drive

Flow.....	2.3 gpm	(8.7 lpm)
Pressure Range.....	100 to 2000 psi	(7 to 140 bar)
RPM.....	1725 rpm	(1725 rpm)
Stroke.....	0.276"	(7 mm)

MODEL 3CP1241.44101 Direct Drive

Flow.....	3.6 gpm	(13.6 lpm)
Pressure Range.....	100 to 2000 psi	(7 to 140 bar)
RPM.....	1725 rpm	(1725 rpm)
Stroke.....	0.433"	(11 mm)

ELECTRIC HORSEPOWER REQUIREMENTS

MODELS	FLOW		PRESSURE			rpm	MOTOR PULLEY SIZE Using 1750 rpm Motor 5.0" Pump Pulley O.D.
			psi 1200	psi 1500	psi 2000		
	U.S. gpm	lpm	bar 85	bar 105	bar 140		Pulley O.D.
3CP1221.44101	4.2	16	35	4.3	5.8	1725	5.0
	3.5	13.2	2.9	3.6	4.8	1450	4.1
	3.0	11.4	2.5	3.1	4.1	1313	3.8
3CP1231.44101	2.3	8.7	1.9	2.4	3.2	1725	Direct Drive
3CP1241.44101	3.6	13.6	3.0	3.7	4.9	1725	Direct Drive

**DETERMINING
THE PUMP R.P.M.**

Rated gpm
Rated rpm

= "Desired" gpm
"Desired" rpm

**DETERMINING
THE REQUIRED H.P.**

gpm x psi
1460

= Electric Brake
H. P. Required

**DETERMINING
MOTOR PULLEY SIZE**

Motor Pulley O.D.
Pump rpm

= Pump Pulley O.D.
Motor rpm

See complete Drive Packages [Incls: Pulleys, Belts, Hubs, Key] Tech Bulletin 003.
Refer to pump **Service Manual** for repair procedure and additional technical information.

PARTS LIST

ITEM	P/N	MATL	DESCRIPTION	QTY
5	92538	S	Screw, HHC Sems (M6x16)	8
8	46901	AL	Cover, Bearing	2
10	76028	FPM	O-Ring, Cover, Bearing - 70D	2
11	76236	FPM	Seal, Oil, Crankshaft	2
15	14480	STL	Bearing, Ball	2
20	48730	TNM	Rod Assembly, Connecting	3
25	46927	FCM	Crankshaft, Dual End - 3CP1221.44101 (M12.7)	1
	46994	FCM	Crankshaft, Dual End - 3CP1231.44101 (M7)	1
	46991	FCM	Crankshaft, Dual End - 3CP1241.44101 (M11)	1
31	76142	AL	Adapter, Breather	1
32	76797	BB	Cap, Vented	1
36	76792	SS	Gauge, Sight	1
37	76791	AL	Adapter, Sight	1
38	44428	NBR	Gasket, Flat, Adapter -80D	1
40	92538	S	Screw, HHC Sems (M6x16)	4
48	25625	STCP	Plug, Drain (1/4"x19 BSP)	1
49	30322	FPM	O-Ring, Drain Plug	1
50	46939	AL	Cover, Rear	1
51	76241	FPM	O-Ring, Rear, Cover	1
53	48644	AL	Crankcase	1
64	46615	CM	Pin, Crosshead	3
65	48459	BBNP	Rod, Plunger	3
70	76739	FPM	Seal, Oil, Crankcase	3
75	43900	S	Slinger, Barrier	3
88	45697	S	Washer, Keyhole (M18 x 10)	3
90	46976	CC	Plunger (M18x43)	3
98	48394	FPM	Washer, Seal - 90D	3
99	48201	SS	Retainer, Plunger	3
100	76541	AL	Retainer, Seal	3
106	76243	ST2	Seal, LPS w/S-Spg	3
110	48556	SS	Manifold, Inlet	1
117	119034	S	Screw, HSH (M8x35)	4
125	76052	ST4	Seal, HPS w/S	3
139	45156	SS	Plug, Inlet, (1/2"-14 NPT)	1
143	11685	FPM	O-Ring, Adapter, Valve, Rear - 85D	3
150	44060	SS	Adapter, Valve	3
154	44927	FPM	O-Ring, Adapter, Valve, Front	3
155	11377	FPM	O-Ring, Adapter, Valve, Rear - 80D	3
157	44059	SS	Adapter, Valve	3
159	11377	FPM	O-Ring, Adapter, Valve, Front - 80D	3
164	44058	SS	Seat	6
165	44928	FPM	O-Ring, Seat - 80D	6
166	44057	SS	Valve	6
167	44056	SS	Spring	6
168	44055	SS	Retainer, Spring	6
185	48558	SS	Manifold, Discharge	1
186	15847	S	Lockwasher (M10)	6
188	87950	S	Screw, HSH (M10x35)	2
189	87952	S	Screw, HSH (M10x55)	4

Optional Parts And accessories On Page 4

Bold face part numbers are unique to a particular pump model.

View Tech Bulletins 002, 003, 024, 036, 043, 073, 074, 077, 083 and 095 for additional information.
 MATERIAL CODES (Not Part of Part Number): AL=Aluminum BBNP=Brass/Nickel Plated CC=Ceramic
 CM=Chrome-moly FPM=Fluorocarbon FCM=Forged Chrome-Moly NBR=Medium Nitrile (Buna-N)
 S=304SS SS=316SS STCP=Steel/Chrome Plated STL=Steel
 TNM=Special High Strength

EXPLODED VIEW

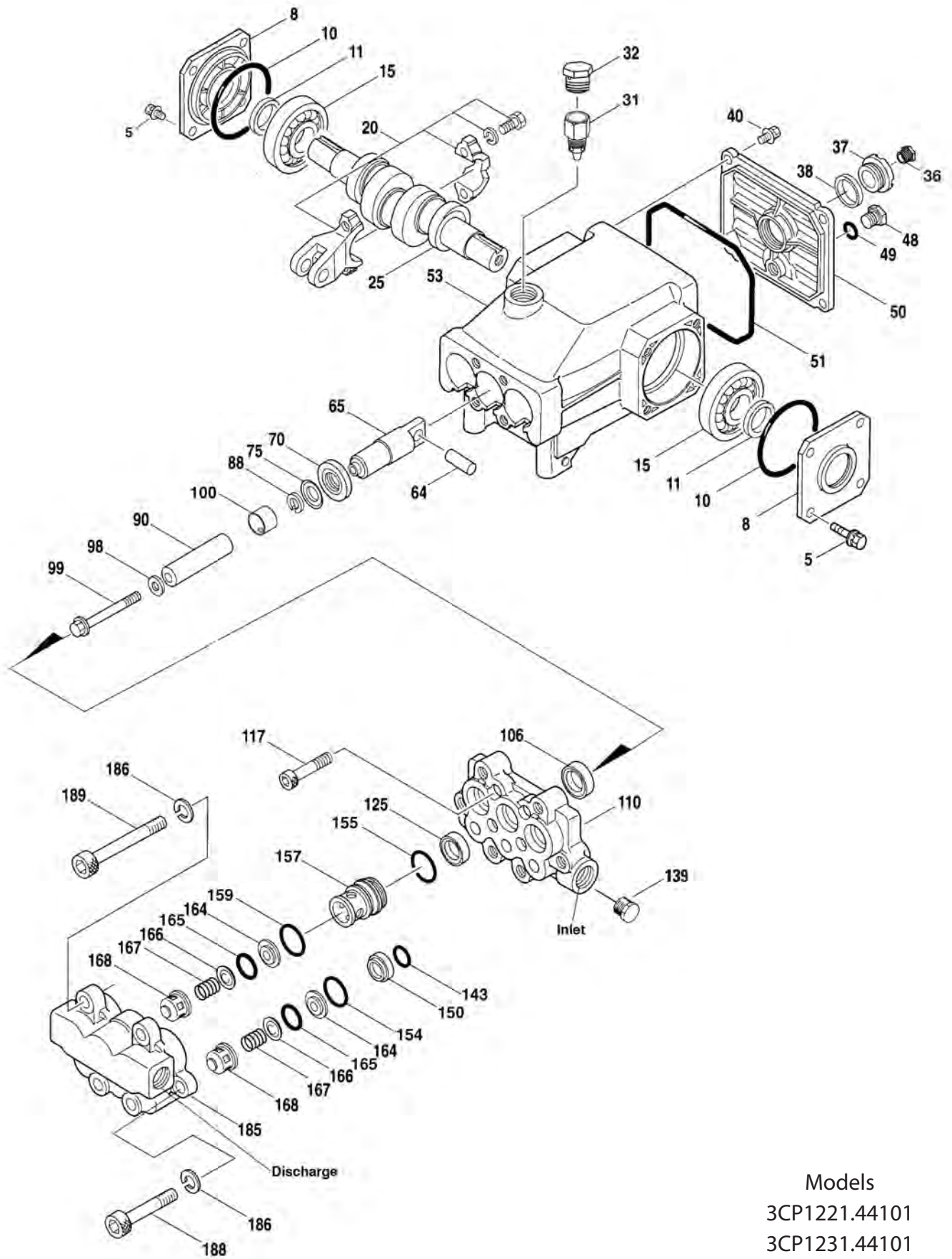



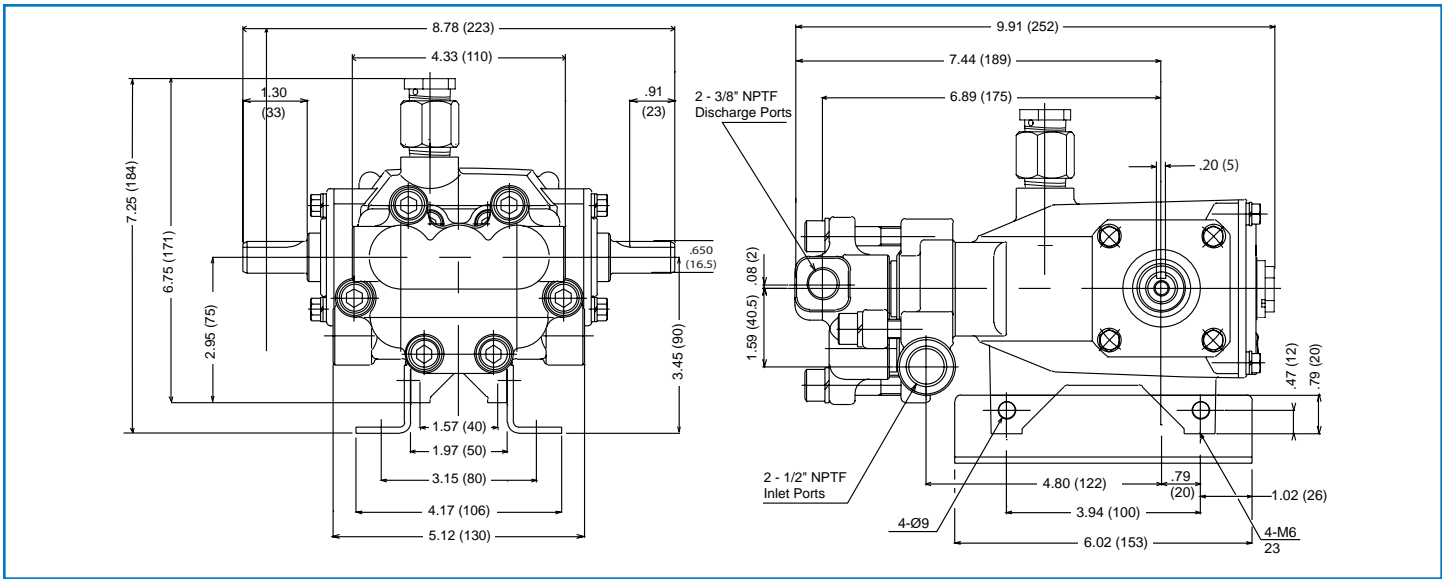



Models
 3CP1221.44101
 3CP1231.44101
 3CP1241.44101
 November 2011

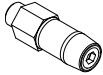
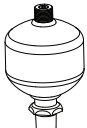

Models 3CP1221.44101, 3CP1231.44101, 3CP1241.44101

OPTIONAL PARTS AND ACCESSORIES

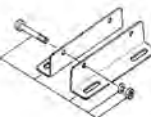
Part Number	Description	QTY		
7003.100	Regulator (Primary Pressure Control)	1		
7501.0110	Unloader (Primary Pressure Control)	1		9961S
7501.1110	Relief Valve (Secondary Pressure Control)	1		
9961S	Pop-Off Valve (Secondary Pressure Control)	1		6030
6073	Pressure Gauge	1		
6030	Accumulator	1		6073
30612	Mounting Rails	1		
118672	Shaft Protector	1		7501.0110 7501.1110
30047	Key (M5x5x24)	1		
76334	Kit, Oil Indicator (3/8" x 24") See Individual Data Sheet	1		118672
34334	Kit, Oil Drain (3/8" x 24") See Individual Data Sheet	1		
76096	Kit, Seal (Includes Items 98, 106, 125, 143, 154, 155, and 159)	1		34334
31216	Kit, Valve (Includes Items 143, 154, 159, 164, 165, 166, 167, and 168)	1		
816719.44101	Complete Head	1		6107
30696	Pliers (Reverse)	1		
44050	Tool, Sight Gauge Removal	1		30612
6107	Oil, Bottle (21 oz.) ISO 68 Hydraulic	1		
6119	Lubricant, Antiseize (1 oz.)	1		

Demand Genuine Cat Pump Parts And Accessories.



CAT PUMPS

1681 - 94TH LANE N.E. MINNEAPOLIS, MN 55449-4324
 PHONE (763) 780-5440 — FAX (763) 780-2958
 e-mail: techsupport@catpumps.com
 www.catpumps.com