

## O.E.M. 3CP Stainless Steel Plunger Pump

### Models

**3CP1221**  
**3CP1231**  
**3CP1241**

## FEATURES

### Superior Design

- Triplex plunger design gives smoother liquid flow.
- Hi-Pressure Seals are completely lubricated and cooled by the liquid being pumped.
- Inlet and discharge valve assemblies interchange for easier maintenance.
- Lubricated Lo-Pressure Seal provides double protection against external leakage.
- Oil bath crankcase assures optimum lubrication.
- Close tolerance concentricity of the ceramic plunger offers perfect alignment and maximizes seal life.

### Quality Materials

- Precision design 316 stainless steel valves and seats are hardened and polished for ultimate seating and extended valve life.
- 316 SSL manifolds for strength and corrosion resistance.
- Special concentric, high density, polished, graphite impregnated, solid ceramic plungers are abrasion resistant and result in extended seal life.
- Specially formulated, CAT PUMP exclusive, Hi-Pressure Seals offer unmatched performance and seal life.
- Die cast aluminum crankcase provides high strength, minimum weight and precision tolerance control.
- Chrome-moly crankshaft gives unmatched strength and surface hardness.
- Oversized crankshaft bearings with greater capacity mean longer bearing life.

### Easy Maintenance

- Wet-end is easily serviced without entering crankcase, requiring less time and effort.
- Preset packings mean no packing gland adjustment is necessary, reducing maintenance costs.

### **⚠ WARNING**

All systems require both a primary pressure regulating device (i.e., regulator, unloader) and a secondary pressure safety relief device (i.e., pop-off valve, safety valve). Failure to install such relief devices could result in personal injury or damage to the pump or to system components. CAT PUMPS does not assume any liability or responsibility for the operation of a customer's high pressure system.

## SPECIFICATIONS

U.S. Measure

Metric Measure

### MODEL 3CP1221

Flow .....4.2 GPM (16 L/M)  
Pressure Range .....100 to 2000 PSI (7 to 140 BAR)  
RPM .....1725 RPM (1725 RPM)  
Stroke .....0.500" (12.7 mm)

### MODEL 3CP1231 Direct Drive

Flow .....2.3 GPM (8.7 L/M)  
Pressure Range .....100 to 2000 PSI (7 to 140 BAR)  
RPM .....1725 RPM (1725 RPM)  
Stroke .....0.276" (7 mm)

### MODEL 3CP1241 Direct Drive

Flow .....3.6 GPM (13.6 L/M)  
Pressure Range .....100 to 2000 PSI (7 to 140 BAR)  
RPM .....1725 RPM (1725 RPM)  
Stroke .....0.433" (11 mm)

### COMMON SPECIFICATIONS

Inlet Pressure Range .....Flooded to 70 PSI (Flooded to 4.9 BAR)  
Bore .....0.709" (18 mm)  
Crankcase Capacity .....10 oz. (0.3 L)  
Maximum Liquid Temperature .....160°F (71°C)  
Above 130°F call CAT PUMPS for inlet conditions and elastomer recommendations.  
Inlet Ports (2) .....1/2" NPTF (1/2" NPTF)  
Discharge Ports (2) .....3/8" NPTF (3/8" NPTF)  
Pulley Mounting.....Either Side (Either Side)  
Shaft Diameter.....0.650" (16.5 mm)  
Weight .....14.84 lbs. (6.7 kg)  
Dimensions .....9.69 x 8.78 x 5.35" (246 x 223 x 136 mm)

## HORSEPOWER REQUIREMENTS

MODEL	FLOW		PRESSURE			MOTOR PULLEY SIZE	
			PSI 1200	PSI 1500	PSI 2000	Using 1750 RPM Motor 5.0" Pump Pulley O.D.	
	U.S. GPM	L/M	BAR 85	BAR 105	BAR 140	RPM	Pulley O.D.
<b>3CP1221</b>	4.2	16	3.5	4.3	5.8	1725	5.0
	3.5	13.2	2.9	3.6	4.8	1531	4.4
	3.0	11.4	2.5	3.1	4.1	1313	3.8
<b>3CP1231</b>	2.3	8.7	1.9	2.4	3.2	1725	Direct Drive
<b>3CP1241</b>	3.6	13.6	3.0	3.7	4.9	1725	Direct Drive

<b>DETERMINING THE PUMP R.P.M.</b>	<u>Rated G.P.M.</u>	=	<u>"Desired" G.P.M.</u>
	Rated R.P.M.	=	"Desired" R.P.M.
<b>DETERMINING THE REQUIRED H.P.</b>	<u>GPM x PSI</u>	=	Electric Brake
	1460	=	H. P. Required
<b>DETERMINING MOTOR PULLEY SIZE</b>	<u>Motor Pulley O.D.</u>	=	<u>Pump Pulley O.D.</u>
	Pump R.P.M.	=	Motor R.P.M.

See complete Drive Packages [Incls: Pulleys, Belts, Hubs, Key] Tech Bulletin 003.  
Refer to pump **Service Manual** for repair procedure, additional technical information and **pump warranty**.

*"Customer confidence is our greatest asset"*

# PARTS LIST

ITEM	P/N	MATL	DESCRIPTION	QTY
2	30047	STL	Key (M5x5x24)	1
5	92538	S	Screw, HHC Sems (M6x16)	8
8	46901	AL	Cover, Bearing	2
10	14028	NBR	O-Ring, Cover, Bearing - 70D	2
11	43222	NBR	Seal, Oil, Crankshaft	2
15	14480	STL	Bearing, Ball	2
20	48730	TNM	Rod Assembly, Connecting	3
25	<b>46927</b>	<b>FCM</b>	Crankshaft, Dual End - 3CP1221	1
	<b>46994</b>	<b>FCM</b>	Crankshaft, Dual End - 3CP1231	1
	<b>46991</b>	<b>FCM</b>	Crankshaft, Dual End - 3CP1241	1
32	45690	RTP	Cap, Oil Filler	1
33	14179	NBR	O-Ring, Oil Filler Cap - 70D	1
37	92241	—	Gauge, Oil, Bubble w/Gasket - 80D	1
38	44428	NBR	Gasket, Flat, Oil Gauge - 80D	1
40	92538	S	Screw, HHC Sems (M6x16)	4
48	25625	STCP	Plug, Drain (1/4"x19 BSP)	1
49	23170	NBR	O-Ring, Drain Plug - 70D	1
50	46939	AL	Cover, Rear	1
51	14041	NBR	O-Ring, Rear, Cover - 70D	1
53	48644	AL	Crankcase	1
64	46615	CM	Pin, Crosshead	3
65	48459	BBNP	Rod, Plunger	3
70	46839	NBR	Seal, Oil, Crankcase	3
75	43900	S	Slinger, Barrier	3
88	45697	S	Washer, Keyhole (M18)	3
90	46976	CC	Plunger (M18x43)	3
98	46730	NBR	Washer, Seal - 90D	3
	48394	FPM	Washer, Seal - 90D	3
	◆ 48432	EPDM	Washer, Seal	3
99	48201	SSL	Retainer, Plunger	3
100	46541	PVDF	Retainer, Seal	3
106	44053	NBR	Seal, LPS w/SS-Spg	3
	44926	FPM	Seal, LPS w/SS-Spg	3
	◆ 46651	EPDM	Seal, LPS w/SS-Spg	3
110	48556	SSL	Manifold, Inlet	1
117	119034	S	Screw, HSH (M8x35)	4
125	44652	SNG	Seal, HPS w/SS	3
	44925	FPM	Seal, HPS w/SS	3
	46652	HT*	Seal, HPS w/SS	3
139	45156	SS	Plug, Inlet, (1/2"-14 NPT)	1
143	17547	NBR	O-Ring, Adapter, Rear - 85D	3
	11685	FPM	O-Ring, Adapter, Rear - 85D	3
	◆ 46648	EPDM	O-Ring, Adapter, Rear - 70D	3
150	44060	SS	Adapter, Valve	3
154	43893	NBR	O-Ring, Adapter, Front - 80D	3
	44927	FPM	O-Ring, Adapter, Front	3
	◆ 46649	EPDM	O-Ring, Adapter, Front - 80D	3
155	26089	NBR	O-Ring, Adapter, Rear - 80D	3
	11377	FPM	O-Ring, Adapter, Rear - 80D	3
	◆ 46647	EPDM	O-Ring, Adapter, Rear - 80D	3
157	44059	SS	Adapter, Valve	3
159	26089	NBR	O-Ring, Adapter, Front - 80D	3
	11377	FPM	O-Ring, Adapter, Front - 80D	3
	◆ 46647	EPDM	O-Ring, Adapter, Front - 80D	3
164	44058	SS	Seat	6
165	44001	NBR	O-Ring, Seat - 80D	6
	44928	FPM	O-Ring, Seat - 80D	6
	◆ 46650	EPDM	O-Ring, Seat - 80D	6
166	44057	SS	Valve	6
167	44056	SS	Spring	6
168	44055	SS	Retainer, Spring	6
185	48558	SSL	Manifold, Discharge	1
186	15847	S	Lockwasher (M10)	6
188	87950	S	Screw, HSH (M10x35)	2
189	87952	S	Screw, HSH (M10x55)	4
250	118672	STCP	Protector, Shaft	1
260	30612	STZP	Rail Assy, Angle (Incls: 26246, 30901, 30910, 30920)	1
270	30246	STL	Pulley & Key Assy (Incls: 30032, 30047)	1
			<b>[See Drive Packages, Tech Bulletin 003]</b>	
277	34422	AL	Bell Housing Assy (56C-145C, 2 Hp)	1
	34423	AL	Bell Housing Assy (182TC-184TC, 7.5 Hp)	1
278	8215	AL	Flexible Coupling Assy (M16.5 to 5/8")	1
	8225	AL	Flexible Coupling Assy (M16.5 to 1-1/8")	1
280	—	—	BD Motors <b>[See Individual Data Sheet]</b>	1
283	34334	—	Kit, Oil Drain	1
290	6104	—	Liquid Gasket (1 oz.)	1
298	34960	STZP	Clutch, Assy Single Groove, 16.5mm, 12VDC	1
	34965	STZP	Clutch, Assy Dual Groove, 16.5mm, 12VDC	1
299	816719	SSL	Head, Complete	1

# EXPLODED VIEW

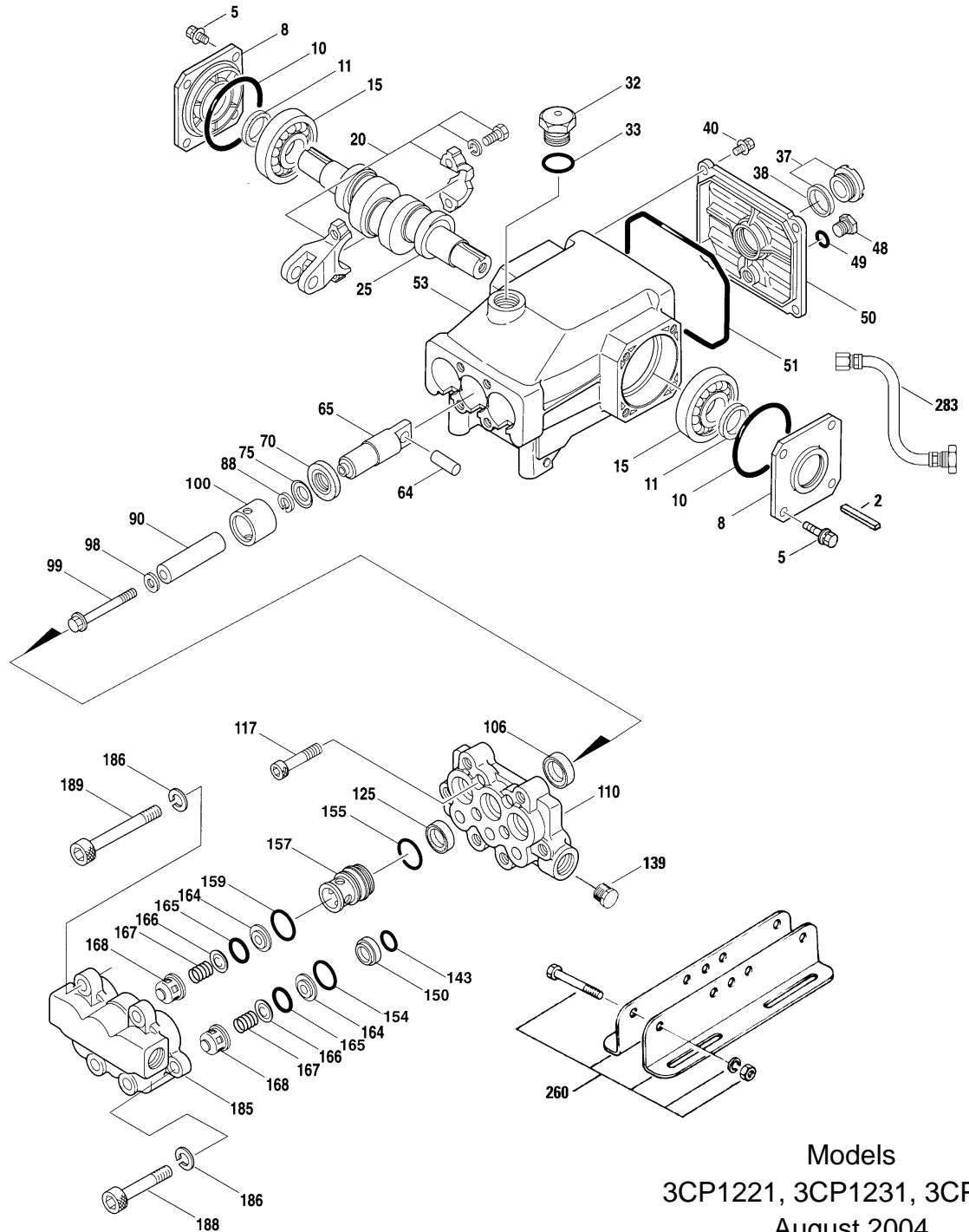

Models  
3CP1221, 3CP1231, 3CP1241  
August 2004

	P/N	MATL		
300	33985	NBR	Kit, Seal (Incls: 98,106,125,143,154,155,159)	1
	33309	FPM	Kit, Seal (Incls: 98,106,125,143,154,155,159)	1
	◆ 33944	EPDM*	Kit, Seal (Incls: 98,106,125,143,154,155,159)	1
310	30982	NBR	Kit, Valve (Incls: 143,154,159,164,165,166,167,168)	1
	31216	FPM	Kit, Valve (Incls: 143,154,159,164,165,166,167,168)	1
	◆ 31217	EPDM	Kit, Valve (Incls: 143,154,159,164,165,166,167,168)	1
350	30696	STZP	Plier, Reverse	1
—	711500	SS	C.A.T. (For R.O. or Industrial Applications)	1
—	711502	SS	Adapter (2 per C.A.T.) (See Data Sheet for complete selection)	2
—	6107	—	Oil, Bottle (21 oz.) ISO 68 Multi-Viscosity Hydraulic (Fill to specified crankcase capacity prior to start-up)	1

**Bold face part numbers are unique to a particular pump model. Italics are optional items. ◆ Silicone oil/grease required.**

\*Review material codes for individual items (HT generally may be used as alternate). **C.A.T. highly recommended for pressurized inlet, R.O. and Industrial applications.**  
See Tech Bulletins 002, 003, 024, 036, 043, 073, 074, 077 and 083 for additional information.

MATERIAL CODES (Not Part of Part Number): AL=Aluminum BBNP=Brass/Nickel Plated CC=Ceramic CM=Chrome-moly  
EPDM=Ethylene Propylene Diene Monomer FPM=Fluorocarbon (Viton®) FCM=Forged Chrome-Moly HT=Hi-Temp (EPDM Alternative) NBR=Medium Nitrile (Buna-N)  
PVDF=Fluoroplastic (High Strength) RTP=Reinforced Composite S=304SS SNG=Special Blend (Buna) SS=316SS SSL=316SS/Low Carbon  
STCP=Steel/Chrome Plated STL=Steel STZP=Steel/Zinc Plated TNM=Special High Strength

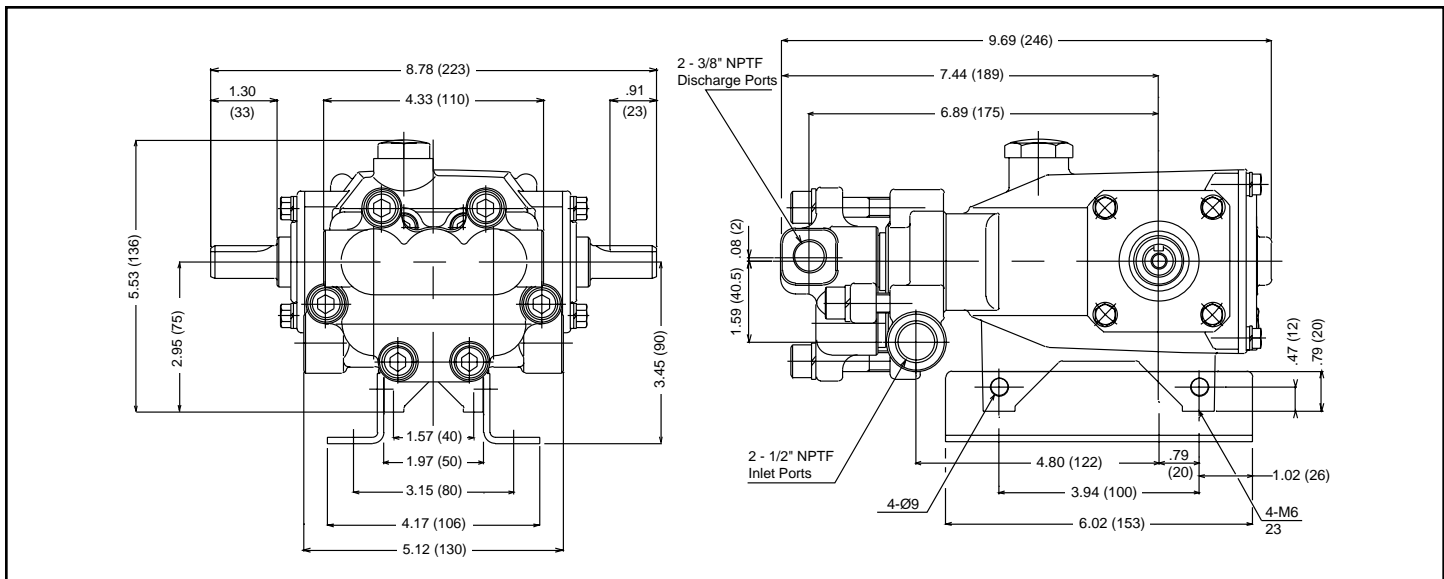

Models 3CP1221, 3CP1231, 3CP1241

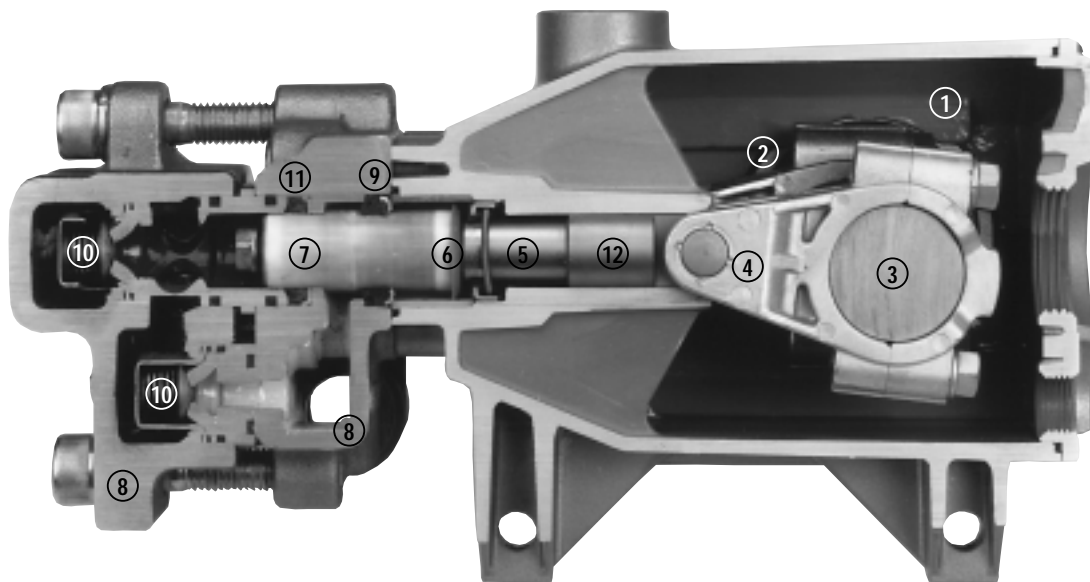

- 1 Die cast aluminum **crankcase** means high strength, lightweight, and excellent tolerance control.
- 2 Oversized crankshaft **bearings** provide extended bearing life and pump performance.
- 3 Chrome-moly **crankshaft** provides unmatched strength and surface hardness for long life.
- 4 Matched oversized TNM **connecting rods** noted for superior tensile strength and bearing quality.
- 5 The **plunger rods** are hardened, surface plated for wear resistance, with high load capacity.
- 6 The stainless steel **slinger** provides back-up protection for the crankcase seal, keeping pumped liquids out of the crankcase.
- 7 Special concentric, high density, polished, graphite impregnated, solid ceramic **plungers** are abrasion resistant and result in extended seal life.
- 8 **Manifolds** are high tensile strength 316 stainless steel for liquid compatibility and long term, continuous duty.
- 9 100% wet **seal** design adds to service life by allowing pumped liquids to cool and lubricate on both sides.
- 10 316 stainless steel **valves, seats and springs** provide corrosion-resistance, ultimate seating and extended life.
- 11 Specially formulated, CAT PUMP exclusive, **Hi-Pressure Seals** offer unmatched performance and seal life.
- 12 **Crossheads** are 360° supported for uncompromising alignment.

Products described hereon are covered by one or more of the following U.S. patents 3558244, 3652188, 3809508, 3920356, 3930756 and 5035580

**World Headquarters**  
**CAT PUMPS**  
 1681 - 94th Lane N.E. Minneapolis, MN 55449-4324  
 Phone (763) 780-5440 — FAX (763) 780-2958  
 e-mail: techsupport@catpumps.com  
 www.catpumps.com

**International Inquiries**  
 FAX (763) 785-4329  
 e-mail: intlsales@catpumps.com



**CAT PUMPS (U.K.) LTD.**  
 1 Fleet Business Park, Sandy Lane, Church Crookham, Fleet  
 Hampshire GU52 8BF, England  
 Phone Fleet 44 1252-622031 — Fax 44 1252-626655  
 e-mail: sales@catpumps.co.uk

**N.V. CAT PUMPS INTERNATIONAL S.A.**  
 Heiveldekens 6A, 2550 Kontich, Belgium  
 Phone 32-3-450.71.50 — Fax 32-3-450.71.51  
 e-mail: cpi@catpumps.be www.catpumps.be

**CAT PUMPS DEUTSCHLAND GmbH**  
 Buchwiese 2, D-65510 Idstein, Germany  
 Phone 49 6126-9303 0 — Fax 49 6126-9303 33  
 e-mail: catpumps@t-online.de www.catpumps.de