

Model 3CP1120 Shown
(Rails and shaft protector sold separately)

FEATURES

- Triplex design offers high efficiency and low pulsation.
- Durable high pressure seals are lubricated and cooled by pumped liquid.
- Pre-set Lo-Pressure Seals provide secondary protection against external leaks and require no packing adjustment.
- Special high-density, polished, concentric plungers provide a true wear surface and extended seal life.
- Specially formulated seals offer unmatched performance and extended life.
- Optional SHTT, FPM and EPDM elastomers for compatibility with many liquids and temperatures up to 200°F.
- Convenient press in style seal case and interchangeable inlet and discharge valves for easy servicing
- Wet-end easily serviced without entering crankcase.

COMMON SPECIFICATIONS

Inlet Pressure Range..... Flooded to 70 PSI (Flooded to 4.9 BAR)
 Bore0.709" (18 mm)
 Crankcase Capacity..... 12 oz. (0.35 L)
 Standard Liquid Temperature 160°F (71°C)
 Above 130°F call CAT PUMPS for inlet conditions and elastomer recommendations.

Inlet Ports (2) 1/2" NPTF (1/2" NPTF)
 Discharge Ports (2) 3/8" NPTF (3/8" NPTF)
 Pulley Mounting Either Side (Either Side)
 Shaft Diameter0.650" (16.5 mm)
 Weight..... 14.84 lbs. (6.7 kg)
 Dimensions.....9.1 x 8.78 x 5.47" (231 x 223 x 139 mm)

⚠ CAUTIONS AND WARNINGS

All High Pressure Systems require a primary pressure regulating device (i.e. regulator, unloader) and a secondary pressure relief device (i.e. pop-off valve, relief valve). Failure to install such relief devices could result in personal injury or damage to pump or property. CAT PUMPS does not assume any liability or responsibility for the operation of a customer's high pressure system.

Read all CAUTIONS and WARNINGS before commencing service or operation of any high pressure system. The CAUTIONS and WARNINGS are included in each service manual and with each Accessory Data sheet. CAUTIONS and WARNINGS can also be viewed online at www.catpumps.com/cautions-warnings or can be requested directly from CAT PUMPS.

WARRANTY

View the Limited Warranty on-line at www.catpumps.com/warranty.

3CP Plunger Pump

Standard Models

**3CP1120, 3CP1130
3CP1140**

Gearbox Model

3CP1120G

SPECIFICATIONS

U.S. Measure

Metric Measure

MODEL 3CP1120 DIRECT DRIVE

Flow4.2 gpm (16 lpm)
 Pressure Range..... 100 to 2200 psi (7 to 155 bar)
 RPM.....1725 rpm (1725 rpm)
 Stroke.....0.500" (12.7 mm)

MODEL 3CP1120G GEARBOX (2.55 : 1 RATIO)

Flow3.5 gpm (13.2 lpm)
 Pressure Range..... 100 to 2200 psi (7 to 155 bar)
 Pump RPM1420 rpm (1420 rpm)
 Engine RPM3600 rpm (3600 rpm)
 Stroke.....0.500" (12.7 mm)

MODEL 3CP1130 DIRECT DRIVE

Flow2.4 gpm (9 lpm)
 Pressure Range..... 100 to 2200 psi (7 to 155 bar)
 RPM.....1725 rpm (1725 rpm)
 Stroke.....0.276" (7 mm)

MODEL 3CP1140 DIRECT DRIVE

Flow3.6 gpm (13.6 lpm)
 Pressure Range..... 100 to 2200 psi (7 to 155 bar)
 RPM.....1725 rpm (1725 rpm)
 Stroke.....0.433" (11 mm)

ELECTRIC HORSEPOWER REQUIREMENTS

MODELS	FLOW		PRESSURE				rpm	MOTOR PULLEY SIZE Using 1750 rpm Motor 5.0" Pump Pulley O.D.
			psi 1200	psi 1500	psi 2000	psi 2200		
	gpm	lpm	bar 85	bar 105	bar 140	bar 155		Pulley O.D.
3CP1120	4.2	16	3.5	4.3	5.8	6.3	1725	Direct Drive
	3.5	13.2	2.9	3.6	4.8	5.3	1531	4.4
	3.0	11.4	2.5	3.1	4.2	4.5	1313	3.8
3CP1130	2.4	9	1.9	2.4	3.2	3.6	1725	Direct Drive
3CP1140	3.6	13.6	3.0	3.7	5.0	5.4	1725	Direct Drive
3CP1120G	3.5	13.2	2.9	3.6	4.8	5.3	1420	Gearbox

DETERMINING THE PUMP R.P.M.

Rated gpm = "Desired" gpm
 Rated rpm = "Desired" rpm

DETERMINING THE REQUIRED H.P.

gpm x psi = Electric Brake
 1460 = H. P. Required

DETERMINING MOTOR PULLEY SIZE

Motor Pulley O.D. = Pump Pulley O.D.
 Pump rpm = Motor rpm

See complete Drive Packages [Incls: Pulleys, Belts, Hubs, Key] Tech Bulletin 003.
 Refer to pump **Service Manual** for repair procedure and additional technical information.

PARTS LIST

ITEM	P/N	MATL	DESCRIPTION	QTY
2	30047	STL	Key (M5x5x24)	1
5	92519	STZP	Screw, HHC Sems (M6x16)	8
	125824	STCP R	Screw, HHC Sems (M6x16)	8
8	46901	AL	Cover, Bearing	2
	48259	AL	Cover, Blind - 3CP1120G	1
10	14028	NBR	O-Ring, Bearing Cover - 70D	2
11	43222	NBR	Seal, Oil, Crankshaft - 70D	1/2
15	14480	STL	Bearing, Ball	2
20	48730	TNM	Rod, Connecting, Assembly [5/01]	3
25	46927	FCM	Crankshaft, Dual End - 3CP1120 (M12.7)	1
	46994	FCM	Crankshaft, Dual End - 3CP1130 (M7)	1
	46991	FCM	Crankshaft, Dual End - 3CP1140 (M11)	1
	48484	FCM	Crankshaft, Single End - 3CP1140CS, (M11)	1
	48257	FCM	Crankshaft, Single End - 3CP1120G (M12.7)	1
32	46798	RTP	Cap, Oil Filler	1
33	14179	NBR	O-Ring, Oil Filler Cap - 70D	1
37	92241	—	Gauge, Oil, Bubble w/Gasket	1
38	44428	NBR	Gasket, Flat, Oil Gauge - 80D	1
40	92519	STZP	Screw, HHC Sems (M6x16)	4
	125824	STCP R	Screw, HHC Sems (M6x16)	4
48	25625	STCP	Plug, Drain (1/4"x19BSP)	1
49	23170	NBR	O-Ring, Drain Plug - 70D	1
50	46939	AL	Cover, Rear	1
51	14041	NBR	O-Ring, Rear Cover - 70D	1
53	48644	AL	Crankcase	1
64	46615	CM	Pin, Crosshead	3
65	48459	BBNP	Rod, Plunger	3
70	46839	NBR	Seal, Oil, Crankcase	3
75	43900	S	Slinger, Barrier	3
88	45697	S	Washer, Keyhole (M18 x 10)	3
90	46976	CC	Plunger (M18x43)	3
98	46730	NBR	Washer, Seal - 90D	3
	48394	FPM	Washer, Seal - 90D	3
99	† 48201	SS	Retainer, Plunger w/Stud (M6)	3
100	46541	PVDF	Retainer, Seal	3
106	43243	NBR	Seal, LPS w/S-Spg	3
	44926	FPM	Seal, LPS w/SS-Spg	3
	76243	ST	Seal, LPS w/S-Spg	3
120	46625	BB	Case, Seal (See Tech Bulletin #110)	3
121	13976	NBR	O-Ring, Seal Case - 70D	3
	48522	FPM	O-Ring, Seal Case	3
125	43245	SNG	Seal, HPS w/S	3
	44925	FPM	Seal, HPS w/SS	3
	46652	HT	Seal, HPS "Hi-Temp", 2-Pc w/S-Support	3
139	43448	BB	Plug, Inlet (1/2"NPT)	1
163	17547	NBR	O-Ring, Seat - 85D	6
	11685	FPM	O-Ring, Seat - 85D	6
164	45790	S	Seat	6
166	43723	S	Valve	6
167	43750	S	Spring	6
168	44565	PVDF	Retainer, Spring	6
172	17615	NBR	O-Ring, Valve Plug - 75D	6
	15855	FPM	O-Ring, Valve Plug - 70D	6
174	46756	BB	Plug, Valve	6
185	46616	FBB	Manifold, Head	1
188	126512	STCP R	Screw, HSH (M8x65)	8
196	22187	BBCP	Plug, Discharge (3/8"NPT)	1
250	118672	STCP	Protector, Shaft	1
260	30612	STZP	Mount, Rail Assy	1
265	30641	—	Mount, Assy (Incls: 30612, 30032, 30047, 118672)	1
270	30246	STL	Assy, Pulley & Key (Incls: 30032, 30047) (See Tech Bulletin 003)	1
283	34334	—	Kit, Oil Drain (3/8" x 24") (See individual Data Sheet)	1
	76334	—	Kit, Oil Indicator (3/8" x 24") (See individual Data Sheet)	1
299	814841	FBB	Head, Complete	1
300	33983	NBR	Kit, Seal (Incls: 98, 106, 121, 125)	1
	33257	FPM	Kit, Seal (Incls: 98, 106, 121, 125)	1
	31983	HT	Kit, Seal (Incls: 98, 106, 121, 125)	1
	76526	STHT	Kit, Seal (Incls: 98, 106, 120, 121, 125) Prior to 4/10	1
	76983	STHT	Kit, Seal (Incls: 98, 106, 121, 125) After 4/10	1
310	33062	NBR	Kit, Valve (Incls: 163, 164, 166, 167, 168, 172)	2
	33258	FPM	Kit, Valve (Incls: 163, 164, 166, 167, 168, 172)	2
350	30696	STZP	Plier, Reverse	1
500	8075	—	Gearbox (See Individual Data Sheet)	1
—	6107	—	Oil, Bottle (21 oz.) ISO 68 Hydraulic (Fill to specified crankcase capacity prior to start-up)	1

Bold print part numbers are unique to a particular pump model. *Italics are optional items.* [] Date of latest production change.

† Production parts are different than repair parts. R Components comply with RoHS Directive.

View Tech Bulletins 002, 003, 024, 036, 064, 073, 074, 077, 083, and 110 for additional information.

For motorized versions see BD motor data sheet. For Gearbox version see 8075 data sheet.

MATERIAL CODES (Not Part of Part Number): AL=Aluminum BB=Brass BBCP=Brass/Chrome Plated BBNP=Brass Nickel Plated CC=Ceramic
 CM=Chrome-moly FBB=Forged Brass FCM=Forged Chrome-Moly FPM=Fluorocarbon HT=Hi-Temp (EPDM Alternative) NBR=Medium Nitrile (Buna-N)
 PVDF=Polyvinylidene Fluoride RTP=Reinforced Composite S=304SS SNG=Special Blend (Buna) ST=Polyetheretherketon
 STHT=Special PTFE High Temp STL=Steel STCP=Steel/Chrome Plated STZP=Steel/Zinc Plated TNM=Special High Strength

EXPLODED VIEW

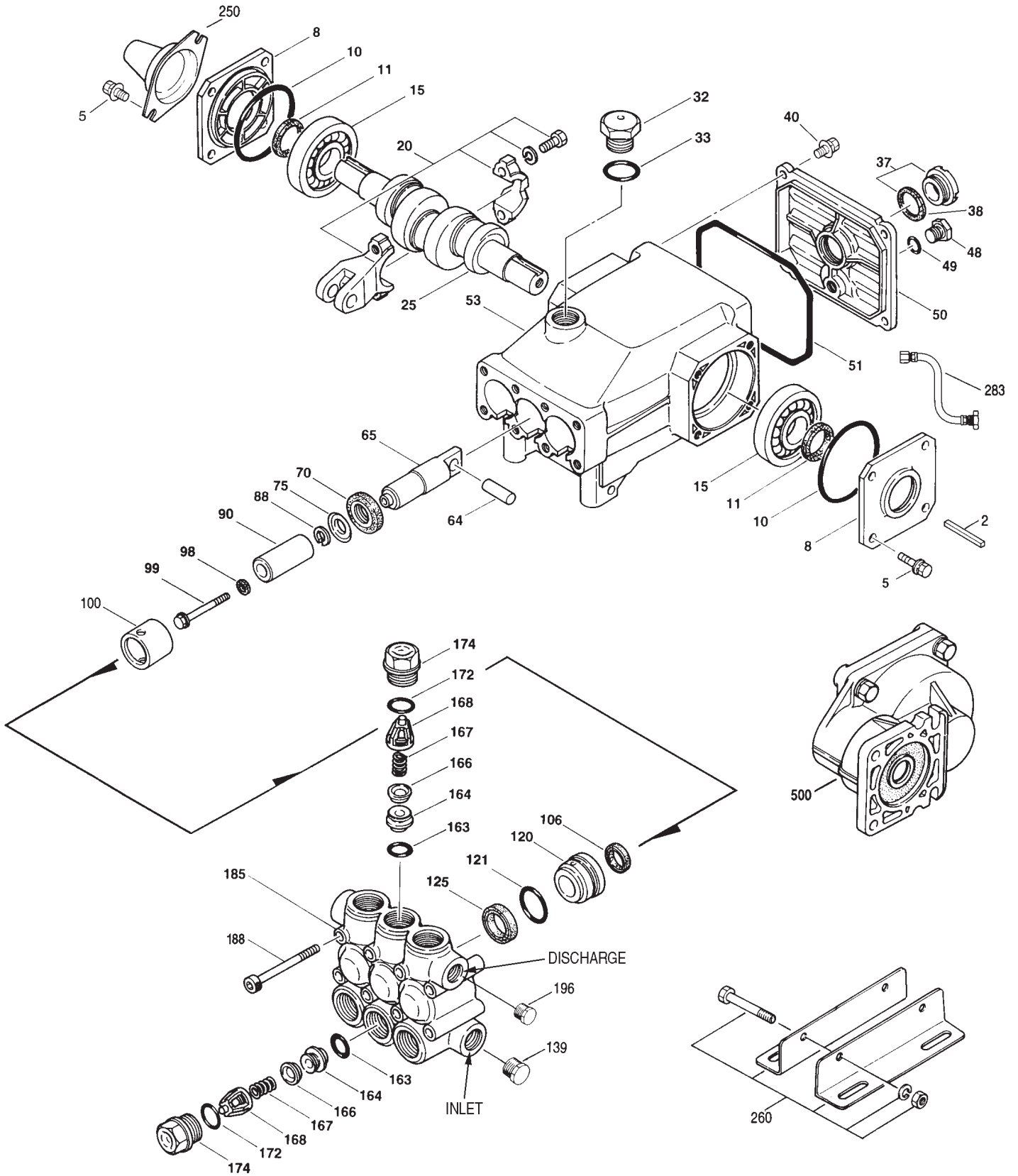

Models
 3CP1120, 3CP1120G,
 3CP1130, 3CP1140
 February 2011

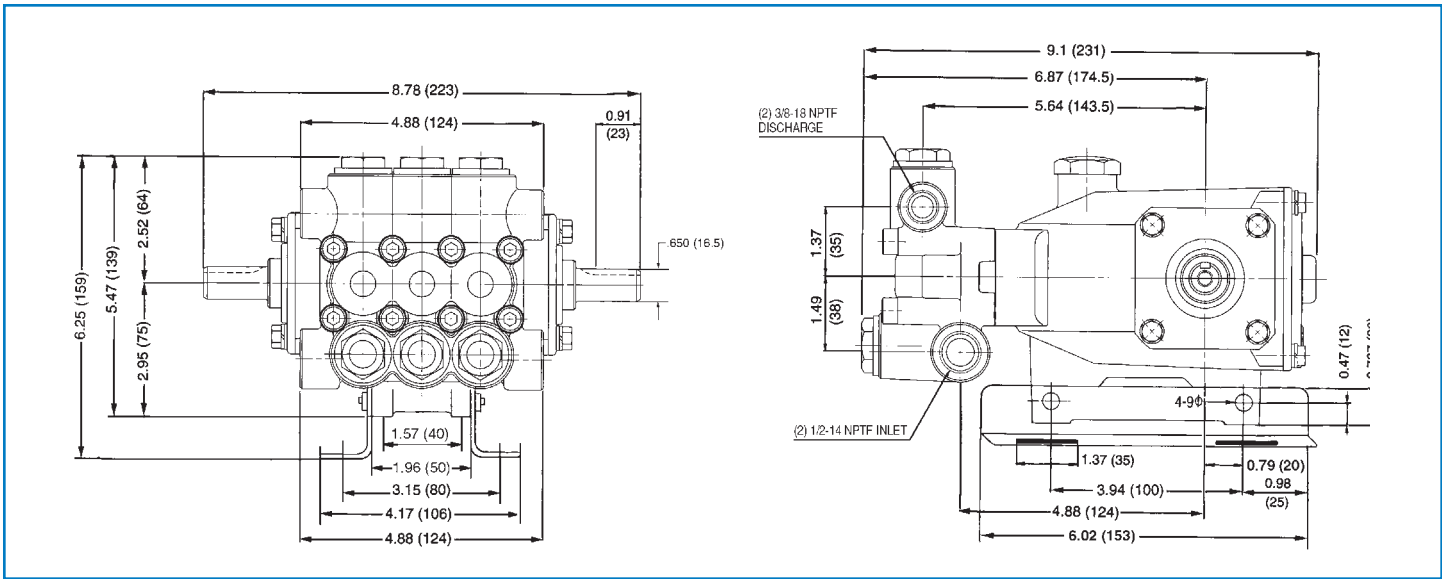

Models 3CP1120, 3CP1120G, 3CP1130, 3CP1140

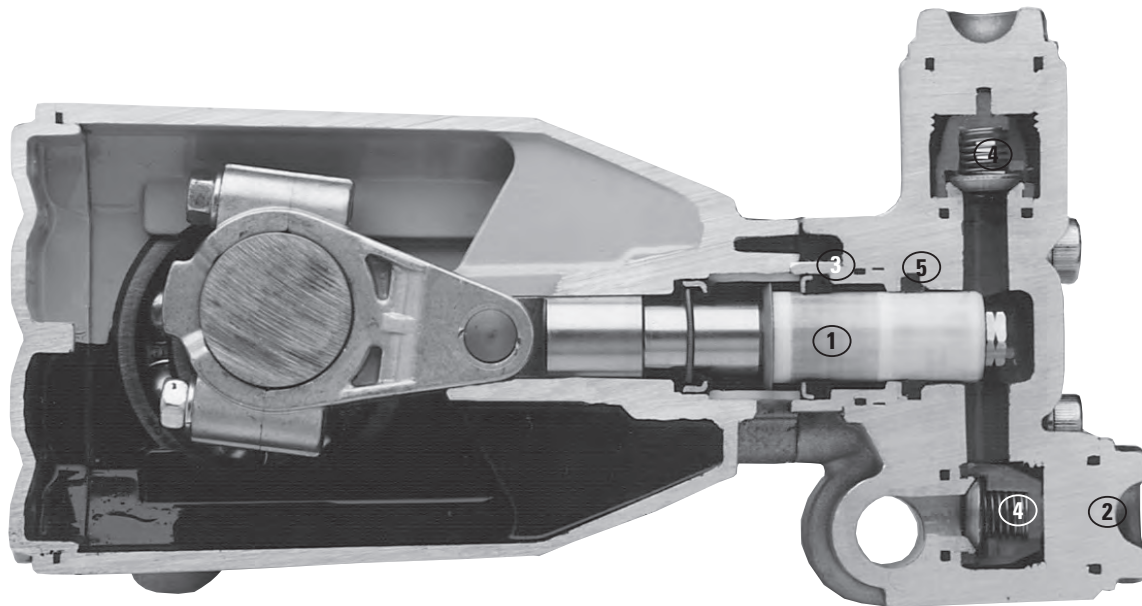

- 1 Special concentric, high-density, polished, solid ceramic **plungers** provide a true wear surface and extended seal life.
- 2 **Manifolds** are a high tensile strength forged brass for long term, continuous duty.
- 3 100% wet **seal** design adds to service life by allowing pumped liquids to cool and lubricate on both sides of the seals.
- 4 Stainless steel **valves, seats and springs** provide corrosion-resistance, ultimate seating and extended life.
- 5 Specially formulated, Cat Pump exclusive, **Hi-Pressure Seals** offer unmatched performance and seal life.



CAT PUMPS
 1681 - 94TH LANE N.E. MINNEAPOLIS, MN 55449-4324
 PHONE (763) 780-5440 — FAX (763) 780-2958
 e-mail: techsupport@catpumps.com
 www.catpumps.com