

Model 3545 Shown

35 Frame Plunger Pumps

Forged Brass Model

3545

Stainless Steel Model

3541

SS Flushed Model

3541C

NAB Flushed Model

3547C

FEATURES

Superior Design

- Triplex plunger design gives smoother liquid flow.
- V-Packings are completely lubricated and cooled by the liquid being pumped.
- Special Flushed Inlet Manifold permits external flush for added cooling with high temperature liquids and lubrication with low lubricity liquids.
- Lubricated Lo-Pressure Seal provides double protection against external leakage.
- Oil bath crankcase assures optimum lubrication.
- Close tolerance concentricity of the ceramic plunger maximizes seal life.

Quality Materials

- Precision design 304 and 316 stainless steel valves and seats are hardened and polished for ultimate seating and extended valve life.
- Forged brass, 316 stainless steel, duplex stainless steel or nickel aluminum bronze manifolds for strength and corrosion resistance.
- Special concentric, high-density, polished, solid ceramic plungers provide a true wear surface and extended seal life.
- Specially formulated, CAT PUMP exclusive, V-Packings offer unmatched performance and seal life.
- Die cast aluminum crankcase provides high strength, minimum weight and precision tolerance control.
- Chrome-moly crankshaft gives unmatched strength and surface hardness.
- Oversized crankshaft bearings with greater loading capacity means longer bearing life.

Easy Maintenance

- Wet-end is easily serviced without entering crankcase, requiring less time and effort.
- Inlet and discharge valve assemblies interchange for easier maintenance.
- Valve assemblies are accessible without disturbing piping, for quick service.
- Preset packings mean no packing gland adjustment is necessary, reducing maintenance costs.

SPECIFICATIONS

	U.S. Measure	Metric Measure
Flow.....	45 GPM	(170 L/M)
Pressure Range.....	100 to 1000 PSI	(7 to 70 BAR)
Inlet Pressure Range	Flooded to 70 PSI	(Flooded to 4.9 BAR)
RPM	765 RPM	(765 RPM)
Bore.....	1.772"	(45 mm)
Stroke.....	1.890"	(48 mm)
Crankcase Capacity.....	4.2 Qts.	(4 L)
Maximum Liquid Temperature	140°F	(60°C)
Above 130°F call CAT PUMPS for inlet conditions and elastomer recommendations.		
Inlet Ports (2)	1-1/2" NPTF	(1-1/2" NPTF)
Flushing Ports (2) (3541C, 3547C).....	1/4" NPTF	(1/4" NPTF)
Discharge Ports (2).....	1" NPTF	(1" NPTF)
Pulley Mounting	Either Side	(Either Side)
Shaft Diameter	1.378"	(35 mm)
Weight.....	139 lbs.	(63 kg)
Dimensions.....	23.89 x 18.11 x 9.72"	(607 x 460 x 247 mm)

ELECTRIC HORSEPOWER REQUIREMENTS

FLOW		PRESSURE			RPM
		PSI 800	PSI 900	PSI 1000	
U.S. GPM	L/M	BAR 55	BAR 63	BAR 70	
45	170	24.7	27.8	30.9	765
40	151	22.0	24.7	27.4	680
35	133	19.2	21.6	24.0	595

⚠ CAUTIONS AND WARNINGS

All High Pressure Systems require a primary pressure regulating device (i.e. regulator, unloader) and a secondary pressure safety relief device (i.e. pop-off valve, safety valve, relief valve). Failure to install such relief devices could result in personal injury or damage to pump or property. CAT PUMPS does not assume any liability or responsibility for the operation of a customer's high pressure system.

Read all CAUTIONS and WARNINGS before commencing service or operation of any high pressure system. The CAUTIONS and WARNINGS are included in each service manual and with each Accessory Data Sheet. CAUTIONS and WARNINGS can also be viewed online at www.catpumps.com/cautions-warnings or can be requested directly from CAT PUMPS.

**DETERMINING
THE PUMP R.P.M.**

$\frac{\text{Rated G.P.M.}}{\text{Rated R.P.M.}} = \frac{\text{"Desired" G.P.M.}}{\text{"Desired" R.P.M.}}$

**DETERMINING
THE REQUIRED H.P.**

$\frac{\text{GPM x PSI}}{1460} = \text{Electric Brake H. P. Required}$

**DETERMINING
MOTOR PULLEY SIZE**

$\frac{\text{Motor Pulley O.D.}}{\text{Pump R.P.M.}} = \frac{\text{Pump Pulley O.D.}}{\text{Motor R.P.M.}}$

See complete Drive Packages [Incls: Pulleys, Belts, Hubs, Key] Tech Bulletin 003.
Refer to pump **Service Manual** for repair procedure and additional technical information.

"Customer confidence is our greatest asset"

PARTS LIST

ITEM	PART NUMBER				DESCRIPTION	QTY		
	3545	MATL	3541	MATL	3547C	MATL		
2	34021	STL	34021	STL	34021	STL	Key (M10x8x70)	1
5	125753	S	125753	S	125753	S	Screw, HH Sems (M8x25)	8
8	44542	AL	44542	AL	44542	AL	Cover, Bearing	2
9	815279	FBR	815279	FBR	815279	FBR	Shim, Split 2-PC	4
10	12398	NBR	12398	NBR	12398	NBR	O-Ring, Bearing Cover - 70D	2
11	13296	NBR	13296	NBR	13296	NBR	Seal, Oil, Crankshaft	2
15	29326	STL	29326	STL	29326	STL	Bearing, Roller	2
20	121467	TNM	121467	TNM	121467	TNM	Rod, Connecting Assembly (Incls: 21, 22, 23) [10/00]	3
21	126749	STCP R	126749	STCP R	126749	STCP R	Washer, Locking (M10)	6
22	126574	STZP R	126574	STZP R	126574	STZP R	Washer, Flat (M10)	6
23	122045	STZP	122045	STZP	122045	STZP	Screw, HH (M10x55)	3
25	29325	FCM	29325	FCM	29325	FCM	Crankshaft, Dual End	1
31	828710	—	828710	—	828710	—	Protector, Cap w/Foam Gasket	1
32	43211	ABS	43211	ABS	43211	ABS	Cap, Oil Filler	1
33	14177	NBR	14177	NBR	14177	NBR	O-Ring, Oil Filler Cap - 70D	1
34	126743	STCP R	126743	STCP R	126743	STCP R	Bolt, Eye (M12x1.75) (For Lifting Pump Only)	1
37	92241	—	92241	—	92241	—	Gauge, Oil, Bubble w/Gasket	1
38	44428	NBR	44428	NBR	44428	NBR	Gasket, Flat, Oil Gauge - 80D	1
40	125753	S	125753	S	125753	S	Screw, HH Sems (M8x25)	8
48	25625	STCP	25625	STCP	25625	STCP	Plug, Drain (1/4"x19 BSP)	1
49	23170	NBR	23170	NBR	23170	NBR	O-Ring, Drain Plug - 70D	1
50	45936	AL	45936	AL	45936	AL	Cover, Rear	1
51	16612	NBR	16612	NBR	16612	NBR	O-Ring, Crankcase Cover - 70D	1
53	44487	AL	44487	AL	44487	AL	Crankcase Assy (Incls: 34, 54)	1
54	27488	S	27488	S	27488	S	Pin, Guide	2
56	27790	POP	27790	POP	27790	POP	Pan, Oil	1
59	92538	S	92538	S	92538	S	Screw, HHC Sems (M6x16)	2
64	43864	CM	43864	CM	43864	CM	Pin, Crosshead	3
65	† 45116	SSZZ	† 45116	SSZZ	† 45116	SSZZ	Rod, Plunger	3
69	126587	STCP R	126587	STCP R	126587	STCP R	Washer, Oil Seal	3
70	100488	NBRS	100488	NBRS	100488	NBRS	Seal, Oil, Crankcase	3
	44739	FPM	44739	FPM	44739	FPM	Seal, Oil, Crankcase	3
75	43865	S	43865	S	43865	S	Slinger, Barrier	3
88	45676	S	45676	S	45676	S	Washer, Keyhole (M16)	3
90	46806	CC	46806	CC	46806	CC	Plunger (M45x145)	3
95	† 89778	SS	† 89778	SS	† 89778	SS	Stud, Plunger Retainer (M10x135)	3
96	20189	PTFE	20189	PTFE	20189	PTFE	Back-up-Ring, Plunger Retainer	3
97	11345	NBR	11345	NBR	11345	NBR	O-Ring, Plunger Retainer - 70D	3
	11375	FPM	11375	FPM	11375	FPM	O-Ring, Plunger Retainer	3
	◆ 701490	EPDM	◆ 701490	EPDM	◆ 701490	EPDM	O-Ring, Plunger Retainer	3
98	44085	SS	44085	SS	44085	SS	Gasket, Retainer	3
99	† 44084	SS	† 44084	SS	† 44084	SS	Retainer, Plunger (M10)	3
100	44119	PPG	44119	PPG	44119	PPG	Retainer, Seal (See Tech Bulletin 105)	3
106	46809	NBR	—	—	—	—	Seal, LPS w/S-Spg	3
	—	—	48384	NBR	48384	NBR	Seal, LPS w/SS-Spg	3
	702013	SFTB*	702013	SFTB*	702013	SFTB*	Seal, LPS w/SS-Spg	3
	◆ 46945	EPDM	◆ 46945	EPDM	◆ 46945	EPDM	Seal, LPS w/SS-Spg	3
107	46811	BB	48380	D	48380	D	Spacer, LPS	3
110	49482	BBCP R	48375	SS	—	—	Manifold, Inlet	1
	—	—	49304	SS	49308	NAB	Manifold, Inlet, Flushed (1/4" Flush Port)	1
112	18688	NBR	18688	NBR	18688	NBR	O-Ring, Inlet Manifold - 70D	3
	11739	FPM	11739	FPM	11739	FPM	O-Ring, Inlet Manifold	3
	◆ 701659	EPDM	◆ 701659	EPDM	◆ 701659	EPDM	O-Ring, Inlet Manifold - 70D	3
117	44585	S	44585	S	44585	S	Screw, HSH (M14x40)	4
126	46812	BB	48383	D	48383	D	Adapter, Female	3
127	46813	STG*	48313	STG*	46813	STG*	V-Packing	6
128	46814	BB	48386	SS	49319	NAB	Adapter, Male	3
141	49483	SS	49483	SS	49483	SS	Spring, Coil, Large (See Tech Bulletin 107)	3
155	17784	NBR	17784	NBR	17784	NBR	O-Ring, V-Packing Spacer - 80D	3
	20138	FPM	20138	FPM	20138	FPM	O-Ring, V-Packing Spacer - 80D	3
	◆ 701658	EPDM	◆ 701658	EPDM	◆ 701658	EPDM	O-Ring, V-Packing Spacer - 80D	3
157	49484	BB	49506	SS	49507	NAB	Spacer, V-Packing (See Tech Bulletin 107)	3
159	17784	NBR	17784	NBR	17784	NBR	O-Ring, V-Packing Spacer - 80D	3
	20138	FPM	20138	FPM	20138	FPM	O-Ring, V-Packing Spacer - 80D	3
	◆ 701658	EDPM	◆ 701658	EDPM	◆ 701658	EDPM	O-Ring, V-Packing Spacer - 80D	3
163	26143	NBR	26143	NBR	26143	NBR	O-Ring, Seat - 80D	6
	14331	FPM	14331	FPM	14331	FPM	O-Ring, Seat - 70D	6
	◆ 701660	EPDM	◆ 701660	EPDM	◆ 701660	EPDM	O-Ring, Seat	6
164	46822	S	48393	SS	48393	SS	Seat	6
166	43932	S	44108	SS	44108	SS	Valve	6
167	44109	SS	44109	SS	44109	SS	Spring, Valve	6
168	44728	PVDF	44728	PVDF	44728	PVDF	Retainer, Spring	6
170	44729	SS	44729	SS	44729	SS	Washer, Spring Retainer	6
171	44644	SS	44644	SS	44644	SS	Coil Spring (70kg), Valve Plug	6
172	89827	NBR	89827	NBR	89827	NBR	O-Ring, Valve Plug - 90D	6
	11747	FPM	11747	FPM	11747	FPM	O-Ring, Valve Plug - 90D	6
	◆ 701494	EPDM	◆ 701494	EPDM	◆ 701494	EPDM	O-Ring, Valve Plug - 70D	6
173	48364	D	48364	D	48364	D	Back-up-Ring, Valve Plug	6
174	46444	FBB	49300	SSD	49300	SSD	Plug, Valve	6
185	49486	BBCP R	49302	SSD	49309	NAB	Manifold, Discharge	1
188	89981	S	89981	S	89981	S	Screw, HSH (M12x70)	8
250	44516	NY	44516	NY	44516	NY	Protector, Shaft w/2 Screws, Washers, Lockwashers	1
255	34018	STZP R	34018	STZP R	34018	STZP R	Kit, Direct Mount	1
	34039	S	34039	S	34039	S	Kit, Direct Mount	1

EXPLODED VIEW

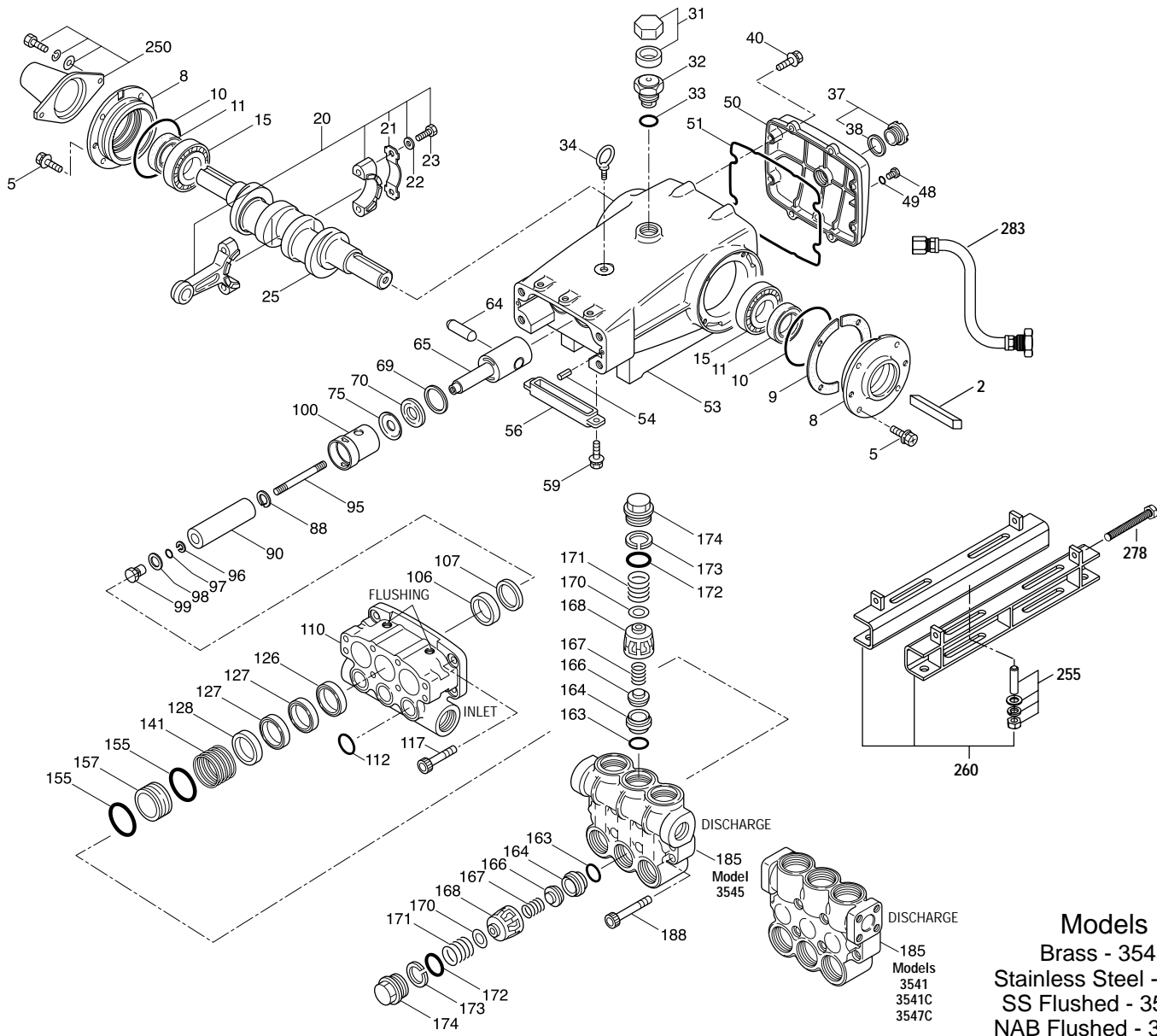

Models
 Brass - 3545
 Stainless Steel - 3541
 SS Flushed - 3541C
 NAB Flushed - 3547C

	3545	MATL	3541	MATL	3547C	MATL		
260	92674	STZP R	92674	STZP R	92674	STZP R	Mounting, Box Assy (Incls 34018)	1
275	990013	STL	990013	STL	990013	STL	Hub, 'B' 35mm w/Keyway [See Drive Packages Tech Bulletin 003]	1
278	80540	ZP	80540	ZP	80540	ZP	Screw, HH (M12x100) (Rail Adjusting Screw)	1
283	34314	—	34314	—	34314	—	Kit, Oil Drain (3/8" x 48")	1
290	6124	—	6124	—	6124	—	Gasket, Liquid (3 oz.)	1
299	818428	BBCP R	818371	SS	—	—	Head, Complete	1
300	33234	NBR*	33834	NBR*	33834	NBR*	Kit, Seal (Incls: 97, 106, 112, 127, 155, 159)	1
	31261	FPM	31261	FPM	31261	FPM	Kit, Seal (Incls: 97, 106, 112, 127, 155, 159)	1
	◆ 33223	EPDM*	◆ 33223	EPDM*	◆ 33223	EPDM*	Kit, Seal (Incls: 97, 106, 112, 127, 155, 159)	1
310	33235	NBR	33835	NBR	33835	NBR	Kit, Valve, Preassembled (Incls: 163, 164, 166, 167, 168, 170, 172, 173)	2
	31262	FPM	31262	FPM	31262	FPM	Kit, Valve, Preassembled (Incls: 163, 164, 166, 167, 168, 170, 172, 173)	2
	◆ 31235	EPDM	◆ 31264	EPDM	◆ 31264	EPDM	Kit, Valve, Preassembled (Incls: 163, 164, 166, 167, 168, 170, 172, 173)	2
390	714500	SS	714500	SS	714500	SS	C.A.T. (Inlet pressure stabilizer for RO and boosted inlet applications)	1
391	714506	SS	714506	SS	714506	SS	Adapter, (2 per C.A.T.) (See Data Sheet for complete selection)	2
392	701828	SS	701828	SS	701828	SS	Elbow Assy used with Adapter Assy 714506	1
—	819000	F	819000	F	819000	F	Assy, Crankcase, Cast Iron Conversion	1
—	6575	—	6575	—	6575	—	Plunger Pump Service DVD	1
—	6100	—	6100	—	6100	—	Oil, Case (12 Bottles) ISO-68 Hydraulic (Fill to specified crankcase capacity prior to start-up)	1
—	—	—	6119	—	6119	—	Lubricant, Antisieze (1 oz.)	1

Bold print part numbers are unique to a particular pump model. Italics are optional items. [] Date of latest production change. ◆ Silicone oil/grease required.

† Production parts are different than repair parts. R Components comply with RoHS Directive. * Review individual parts in each kit for material code identification.

See Tech Bulletins 002, 003, 024, 036, 041, 043, 053, 074, 077, 083, 099, 105 and 107 for additional information.

Pressurized Inlet and C.A.T. highly recommended for Hi-Temp, R.O. and industrial applications.

MATERIAL CODES (Not Part of Part Number): ABS=ABS Plastic AL=Aluminum BB=Brass BBCP=Brass/Chrome Plated CC=Ceramic CM=Chrome-Moly D=Acetal

EPDM=Ethylene Propylene Diene Monomer F=Cast Iron FBB=Forged Brass FBR=Fiber FCM=Forged Chrome-moly FPM=Fluorocarbon

NBR=Medium Nitrile (Buna-N) NBRs=Buna, Silicone Free NY=Nylon PPG=Glass Filled Polypropylene PTFE=Pure Polytetrafluoroethylene PVDF=Polyvinylidene Fluoride

S=304SS SS=316SS SFTB=Special Blend PTFE Black SSZZ=316SS/Zamak STG=Special Blend PTFE White STL=Steel

STCP=Steel/Chrome Plated STZP=Steel/Zinc Plated TNM=Special High Strength ZP=Zinc Plated

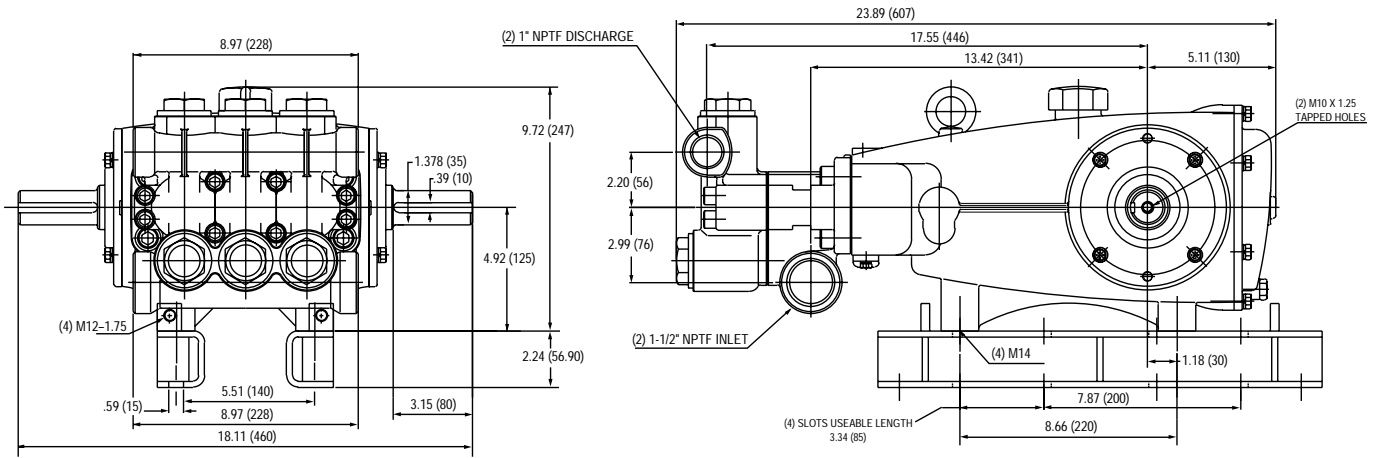

Models 3545, 3541, 3541C, 3547C

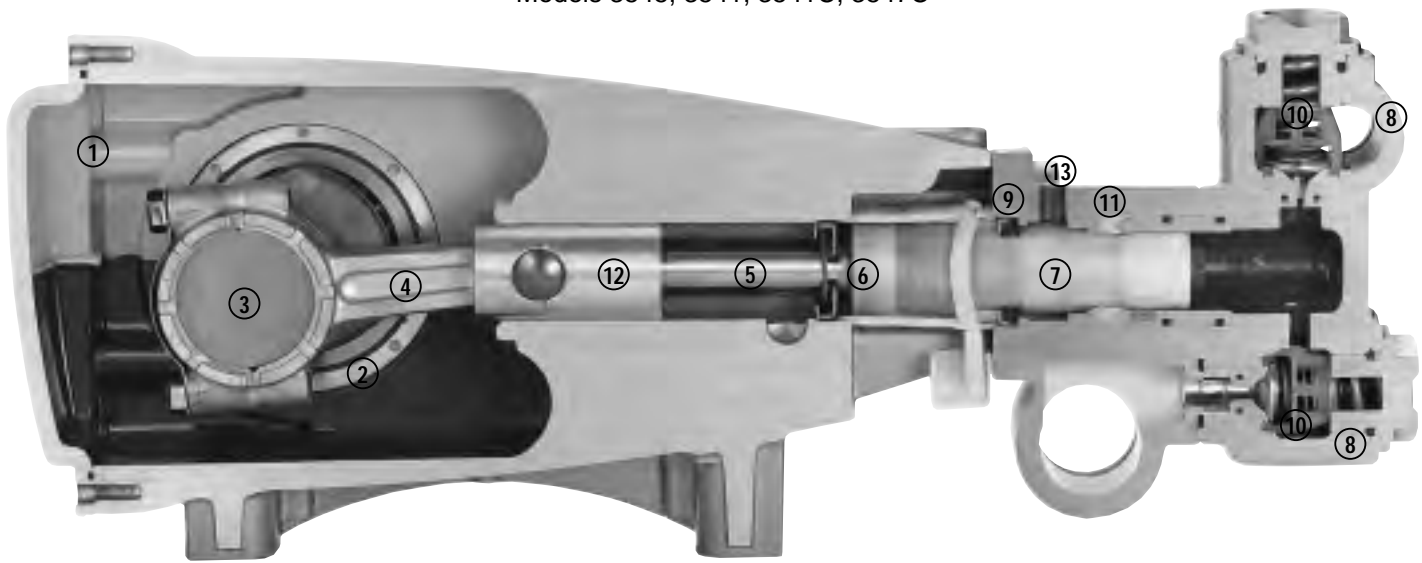

- 1 Die cast aluminum **crankcase** means high strength, lightweight, and excellent tolerance control.
- 2 Oversized crankshaft **bearings** provide extended bearing life and pump performance.
- 3 Chrome-moly **crankshaft** provides unmatched strength and surface hardness for long life.
- 4 Matched oversized TNM **connecting rods** noted for superior tensile strength and bearing quality.
- 5 Special stainless steel high strength **plunger rods** for high load bearing and longevity.
- 6 The stainless steel **slinger** provides back-up protection for the crankcase seal, keeping pumped liquids out of the crankcase.
- 7 Special concentric, high-density, polished, solid ceramic **plungers** provide a true wear surface and extended seal life.
- 8 **Manifolds** are a high tensile strength forged brass, 316 stainless steel, duplex stainless steel or nickel aluminum bronze for long term, continuous duty.
- 9 100% wet **seal** design adds to service life by allowing pumped liquids to cool and lubricate on both sides.
- 10 Stainless steel **valves, seats and springs** provide corrosion-resistance, ultimate seating and extended life.
- 11 Specially formulated, CAT PUMP exclusive, **V-Packings** offer unmatched performance and seal life.
- 12 **Crossheads** are 360° supported for uncompromising alignment.
- 13 Special **Flushed Inlet Manifold** permits external flush for added cooling with high temperature liquids and lubrication with low lubricity liquids.

World Headquarters

CAT PUMPS

1681 - 94th Lane N.E. Minneapolis, MN 55449-4324

Phone (763) 780-5440 — FAX (763) 780-2958

e-mail: techsupport@catpumps.com

www.catpumps.com

International Inquiries

FAX (763) 785-4329

e-mail: intlsales@catpumps.com



The Pumps with Nine Lives

CAT PUMPS (U.K.) LTD.

1 Fleet Business Park, Sandy Lane, Church Crookham

FLEET, Hampshire, GU52 8BF, England

Phone Fleet 44 1252-622031 — Fax 44 1252-626655

e-mail: sales@catpumps.co.uk www.catpumps.co.uk

N.V. CAT PUMPS INTERNATIONAL S.A.

Heiveldekens 6A, B-2550 Kontich, Belgium

Phone 32-3-450.71.50 — Fax 32-3-450.71.51

e-mail: cpi@catpumps.be www.catpumps.be

CAT PUMPS DEUTSCHLAND GmbH

Buchwiese 2, D-65510 Idstein, Germany

Phone 49 6126-9303 0 — Fax 49 6126-9303 33

e-mail: catpumps@t-online.de www.catpumps.de