

Model 310 Shown
(Rails and Shaft Protector Sold Separately)

FEATURES

- Triplex design offers high efficiency and low pulsation.
- Durable high pressure seals are lubricated and cooled by pumped liquid.
- Pre-set Lo-Pressure Seals provide secondary protection against external leaks and require no packing adjustment.
- Optional STHT, FPM and EPDM elastomers for compatibility with many liquids and temperatures up to 200°F
- Alternate crankshaft strokes offers flexibility with belt, clutch or direct-drive installation.

COMMON SPECIFICATIONS

Bore	0.787"	(20 mm)
Crankcase Capacity.....	18 oz.	(0.55 l)
Standard Liquid Temperature	160°F	(71°C)
Above 130°F call CAT PUMPS for inlet conditions and elastomer recommendations.		
Inlet Ports (2).....	1/2" NPTF	(1/2" NPTF)
Discharge Ports (2).....	3/8" NPTF	(3/8" NPTF)
Shaft Diameter	0.787"	(20 mm)
Weight.....	19.8 lbs.	(9 kg)
Dimensions.....	11.73 x 10.0 x 5.24"	(298 x 254 x 133 mm)

⚠ CAUTIONS AND WARNINGS

All High Pressure Systems require a primary pressure regulating device (i.e. regulator, unloader) and a secondary pressure relief device (i.e. pop-off valve, relief valve). Failure to install such relief devices could result in personal injury or damage to pump or property. CAT PUMPS does not assume any liability or responsibility for the operation of a customer's high pressure system.

Read all CAUTIONS and WARNINGS before commencing service or operation of any high pressure system. The CAUTIONS and WARNINGS are included in each service manual and with each Accessory Data sheet. CAUTIONS and WARNINGS can also be viewed online at www.catpumps.com/cautions-warnings or can be requested directly from CAT PUMPS.

WARRANTY

View the Limited Warranty on-line at www.catpumps.com/warranty.

5 Frame Plunger Pump

Standard Models

310, 340, 350

Special Brass Models

310B, 340B, 350B

Sleeved Models

310S, 340S, 350S

SPECIFICATIONS

U.S. Measure

Metric Measure

MODEL 310, 310B, 310S

Flow	4.0 gpm	(15 l/m)
Pressure Range.....	100 to 2200 psi	(7 to 155 bar)
Pump RPM	950 rpm	(950 rpm)
Inlet Pressure Range.....	-5 to 60 psi	(-0.35 to 4 bar)
Stroke	0.709"	(18 mm)

ALTERNATE SPECIFICATIONS MODEL 310, 310B, 310S

Flow	5.0 gpm	(19 l/m)
Pressure Range.....	100 to 1500 psi	(7 to 105 bar)
Pump RPM	1190 rpm	(1190 rpm)

MODEL 340, 340B, 340S Direct Drive

Flow	4.0 gpm	(15 l/m)
Pressure Range.....	100 to 1800 psi	(7 to 125 bar)
Pump RPM	1725 rpm	(1725 rpm)
Inlet Pressure Range.....	Flooded to 60 psi	(Flooded to 4 bar)
Stroke	0.394"	(10 mm)

MODEL 350, 350B, 350S Direct Drive

Flow	5.0 gpm	(19 l/m)
Pressure Range	100 to 1500 psi	(7 to 105 bar)
Pump RPM	1725 rpm	(1725 rpm)
Inlet Pressure Range.....	Flooded to 60 psi	(Flooded to 4 bar)
Stroke	0.472"	(12 mm)

ELECTRIC HORSEPOWER REQUIREMENTS

MODELS	FLOW		PRESSURE					rpm	MOTOR PULLEY SIZE Using 1725 rpm Motor & Std. 8" Pump Pulley
			psi 1200	psi 1500	psi 1800	psi 2000	psi 2200		
	U.S. gpm	l/m	bar 85	bar 105	bar 125	bar 140	bar 155		
310	4.0	15	3.3	4.1	5.0	5.5	6.0	950	4.4
Alternate	5.0	19	4.1	5.1	N/A	N/A	N/A	1190	5.5
340	4.0	15	3.3	4.1	5.0	N/A	N/A	1725	Direct Drive
350	5.0	19	4.1	5.1	N/A	N/A	N/A	1725	Direct Drive

DETERMINING THE PUMP R.P.M.	$\frac{\text{Rated gpm}}{\text{Rated gpm}}$	=	$\frac{\text{"Desired" gpm}}{\text{"Desired" rpm}}$
DETERMINING THE REQUIRED H.P.	$\frac{\text{gpm} \times \text{psi}}{1460}$	=	Electric Brake H. P. Required
DETERMINING MOTOR PULLEY SIZE	$\frac{\text{Motor Pulley O.D.}}{\text{Pump rpm}}$	=	$\frac{\text{Pump Pulley O.D.}}{\text{Motor rpm}}$

See complete Drive Packages [Incls: Pulleys, Belts, Hubs, Key] Tech Bulletin 003. Refer to pump **Service Manual** for repair procedure and additional technical information.

PARTS LIST

ITEM	PART NUMBERS						DESCRIPTION	QTY
	310, 340		310B,340B		310S, 340S			
	350	MATL	350B	MATL	350S	MATL		
2	30057	STL	30057	STL	30057	STL	Key (M6x6x25)	1
5	92519	STZP	92519	STZP	92519	STZP	Screw, HHC, Sems (M6x16)	8
	125824	STCPR	125824	STCPR	125824	STCPR	Screw, HHC, Sems (M6x16)	8
8	43344	AL	43344	AL	43344	AL	Cover, Bearing	1/2
10	43343	NBR	43343	NBR	43343	NBR	O-Ring, Bearing Cover - 70D	2
11	43222	NBR	43222	NBR	43222	NBR	Seal, Oil, Crankshaft - (310, 310B, 310S,350,350B,350S-2) (340,340B,340S-1)	2/1
15	14480	STL	14480	STL	14480	STL	Bearing, Ball	2
20	45883	HS	45883	HS	45883	HS	Rod, Connecting Assy [09/05]	3
25	43342	FCM	43342	FCM	43342	FCM	Crankshaft, Dual End - M18, 310, 310B, 310S	1
	44945	FCM	44945	FCM	44945	FCM	Crankshaft, Single End -M10, 340, 340B, 340S	1
	43838	FCM	43838	FCM	43838	FCM	Crankshaft, Dual End - M12, 350, 350B, 350S	1
30	44949	AL	44949	AL	44949	AL	Cover, Blind Shaft - 340, 340B, 340S	1
31	828710	—	828710	—	828710	—	Protector, Oil Cap w/Foam Gasket	1
32	43211	ABS	43211	ABS	43211	ABS	Cap, Oil Filler	1
33	14177	NBR	14177	NBR	14177	NBR	O-Ring, Filler Cap - 70D	1
37	92241	—	92241	—	92241	—	Gauge, Oil, Bubble w/Gasket	1
38	44428	NBR	44428	NBR	44428	NBR	Gasket, Flat, Oil Gauge - 80D	1
40	92520	STZP	92520	STZP	92520	STZP	Screw, HHC, Sems (M6x20)	4
	126541	STCPR	126541	STCPR	126541	STCPR	Screw, HHC, Sems (M6x20)	4
48	25625	STCP	25625	STCP	25625	STCP	Plug, Drain (1/4"x19 BSP)	1
49	23170	NBR	23170	NBR	23170	NBR	O-Ring, Drain Plug - 70D	1
50	48772	AL	48772	AL	48772	AL	Cover, Rear [10/01] (See Tech Bulletin 090)	1
51	48773	NBR	48773	NBR	48773	NBR	O-Ring, Rear Cover [10/01] (See Tech Bulletin 090)	1
53	48769	AL	48769	AL	48769	AL	Crankcase [05/02] (See Tech Bulletin 090)	1
56	43355	POP	43355	POP	43355	POP	Pan, Oil	1
64	43351	CM	43351	CM	43351	CM	Pin, Crosshead	3
65	43365	ZZCP	43365	ZZCP	43365	ZZCP	Rod, Plunger	3
70	43228	NBR	43228	NBR	43228	NBR	Seal, Oil, Crankcase	3
75	43328	S	43328	S	43328	S	Slinger, Barrier	3
88	45697	S	45697	S	45697	S	Washer, Keyhole (M18 x 10)	3
90	43367	CC	43367	CC	43367	CC	Plunger (M20x72)	3
96	43235	PTFE	43235	PTFE	43235	PTFE	Back-up-Ring, Plunger Retainer	3
97	17399	NBR	17399	NBR	17399	NBR	O-Ring, Plunger Retainer - 80D	3
	14160	FPM	14160	FPM	14160	FPM	O-Ring, Plunger Retainer - 80D	3
	◆ 46204	EPDM	◆ 46204	EPDM	◆ 46204	EPDM	O-Ring, Plunger Retainer - 70D	3
98	45891	CU	45891	CU	45891	CU	Gasket	3
99	104360	S	104360	S	104360	S	Retainer, Plunger w/Stud	3
100	45688	PVDF	45688	PVDF	45688	PVDF	Retainer, Seal, 2-Pc [04/06] (See Tech Bulletin 105)	3
101	43302	—	43302	—	43302	—	Wick, Long Tab	3
106	43305	NBR	43305	NBR	43305	NBR	Seal, LPS w/S-Spg	3
	45153	FPM	45153	FPM	45153	FPM	Seal, LPS w/SS-Spg	3
	◆ 48429	EPDM	◆ 48429	EPDM	◆ 48429	EPDM	Seal, LPS w/SS-Spg	3
	76305	ST	76305	ST	76305	ST	Seal, LPS w/S-Spg	3
120	45679	BB	45679	BB	45679	BB	Case, Seal	3
121	14200	NBR	14200	NBR	14200	NBR	O-Ring, Seal Case - 70D	3
	11719	FPM	11719	FPM	11719	FPM	O-Ring, Seal Case	3
	◆ 48907	EPDM	◆ 48907	EPDM	◆ 48907	EPDM	O-Ring, Seal Case	3
125	43307	SNG	43307	SNG	43307	SNG	Seal, HPS w/S	3
	44936	FPM	44936	FPM	44936	FPM	Seal, HPS w/SS	3
	46667	HT*	46667	HT*	46667	HT*	Seal, HPS "Hi-Temp", 2-Pc w/S-Support	3
139	22179	BBCP	22179	BBCP	22179	BBCP	Plug, Inlet (1/2" NPT)	1
162	48361	D	48361	D	48361	D	Back-up-Ring, Seat	6
163	43358	NBR	43358	NBR	43358	NBR	O-Ring, Seat - 70D	6
	44938	FPM	44938	FPM	44938	FPM	O-Ring, Seat - 70D	6
	◆ 48908	EPDM	◆ 48908	EPDM	◆ 48908	EPDM	O-Ring, Seat	6
164	43725	S	43725	S	43725	S	Seat	6
166	43723	S	43723	S	43723	S	Valve	6
167	43750	S	43750	S	43750	S	Spring, Valve	6
168	44565	PVDF	44565	PVDF	44565	PVDF	Retainer, Valve Spring	6
172	17615	NBR	17615	NBR	17615	NBR	O-Ring, Valve Plug - 75D	6
	15855	FPM	15855	FPM	15855	FPM	O-Ring, Valve Plug - 70D	6
	◆ 48431	EPDM	◆ 48431	EPDM	◆ 48431	EPDM	O-Ring, Valve Plug - 75D	6
174	43849	BBCP	43849	BBCP	43849	BBCP	Plug, Valve	6
185	44837	BBCP	49721	SBCP	46278	FBB	Head, Manifold	1
188	126520	STCPR	126520	STCPR	126520	STCPR	Screw, HSH, Sems (M10x35)	2
250	118672	STCP	118672	STCP	118672	STCP	Protector, Shaft (Belt Drive Only)	1
255	30243	STZP	30243	STZP	30243	STZP	Mount, Direct (Belt Drive Only)	1
260	30611	STZP	30611	STZP	30611	STZP	Mounting, Angle Rail (Belt Drive Only)	1
265	30659	—	30659	—	30659	—	Mount, Assy (Incls: 30611, 30633, 118672) (Belt Drive Only)	1
270	30633	STL	30633	STL	30633	STL	Assy, Pulley & Key (Incls: 30058, 30057) (Belt Drive Only)	1
275	30944	STL	30944	STL	30944	STL	Assy, Hub & Key (Incls: 30057, 30945) (Belt Drive Only)	1
283	34334	—	34334	—	34334	—	Kit, Oil Drain (3/8" x 24") (See Individual Data Sheet)	1
	76334	—	76334	—	76334	—	Kit, Oil Indicator, (3/8" x 24) (See Individual Data Sheet)	1
298	34962	STZP	34962	STZP	34962	STZP	Clutch Assy, Single Groove, 20mm, 12VDC (See Individual Data Sheet)	1
	34963	STZP	34963	STZP	34963	STZP	Clutch Assy, Dual Groove, 20mm, 12VDC (See Individual Data Sheet)	1
299	810027	BBCP	818471	SBCP	816551	FBB	Head, Complete	1

EXPLODED VIEW

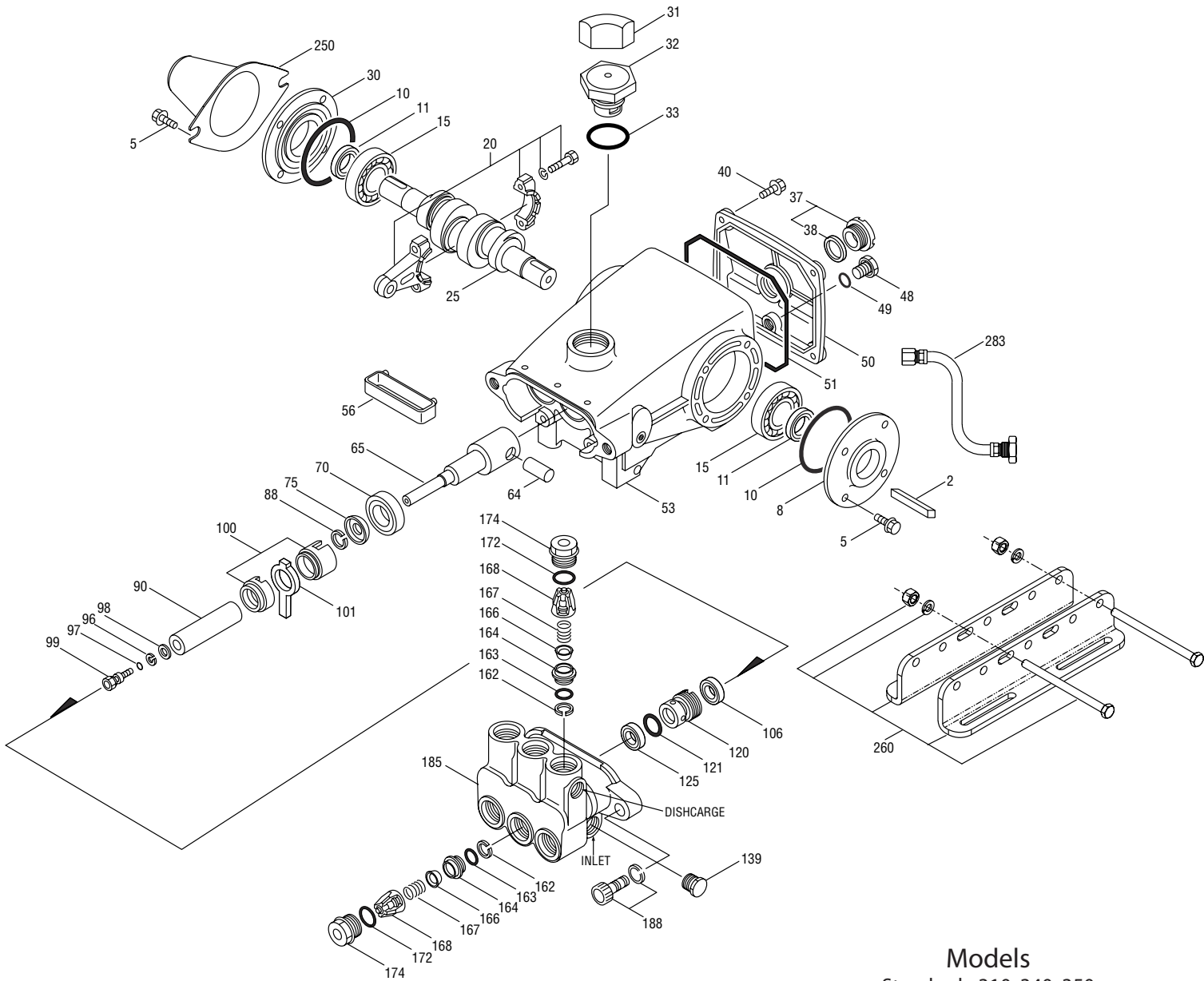

Models
 Standard - 310, 340, 350
 Special Brass - 310B, 340B, 350B
 Sleeved - 310S, 340S, 350S
June 2012

	310, 340		310B, 340B		310S, 340S			
	350	MATL	350B	MATL	350S	MATL		
300	30623	NBR	30623	NBR	30623	NBR	Kit, Seal (Incls: 97,101,106,121,125)	1
	34155	FPM	34155	FPM	34155	FPM	Kit, Seal (Incls: 97,101,106,121,125)	1
	33623	HT	33623	HT	33623	HT	Kit, Seal, "Hi-Temp" (Incls: 97,101,106,121,125)	1
	◆ 31163	EPDM*	◆ 31163	EPDM*	◆ 31163	EPDM*	Kit, Seal (Incls: 97,101,106,121,125)	1
310	30821	NBR	30821	NBR	30821	NBR	Kit, Valve, Preassembled (Incls: 162-164,166-168,172)	2
	31821	FPM	31821	FPM	31821	FPM	Kit, Valve, Preassembled (Incls: 162-164,166-168,172)	2
	◆ 31162	EPDM	◆ 31162	EPDM	◆ 31162	EPDM	Kit, Valve, Preassembled (Incls: 162-164,166-168,172)	2
350	30696	STZP	30696	STZP	30696	STZP	Plier, Reverse	1
351	33004	STZP	33004	STZP	33004	STZP	Socket, Seal Case (1/2" Drive)	1
—	—	—	—	—	—	—	BD Motors - (See Individual Data Sheet)	1
—	6107	—	6107	—	6107	—	Oil, Bottle (21 oz.) ISO-68 Hydraulic	1
							(Fill to specified crankcase capacity prior to start-up)	

Bold print part numbers are unique to a particular pump model. *Italics are optional items.* ◆ Silicone oil/grease required.

R Components comply with RoHS Directive. [] Date of latest production change. *Review individual parts in each kit for material code identification.
 View Tech Bulletins 002, 003, 008, 024, 027, 032, 035, 036, 043, 045, 046, 049, 052, 053, 054, 073, 074, 077, 079, 083, 090, 105 for additional information.
 MATERIAL CODES (Not Part of Part Number): ABS=ABS Plastic AL=Aluminum BB=Brass BBCP=Brass/Chrome Plated CC=Ceramic CM=Chrome-moly CU=Copper
 D=Acetal EPDM=Ethylene Propylene Diene Monomer FBB=Forged Brass FCM=Forged Chrome-moly FPM=Fluorocarbon HS=High Strength
 HT=High Temp (EPDM Alternative) NBR=Medium Nitrile (Buna-N) POP=Polypropylene PTFE=Pure Polytetrafluoroethylene PVDF=Polyvinylidene Fluoride
 S=304SS SBCP=Special Brass/Chrome Plated SNG=Special Blend (Buna) STL=Steel STCP=Steel/Chrome Plated STZP=Steel/Zinc Plated
 ZZCP=Chrome Plated/Steel - Zamak

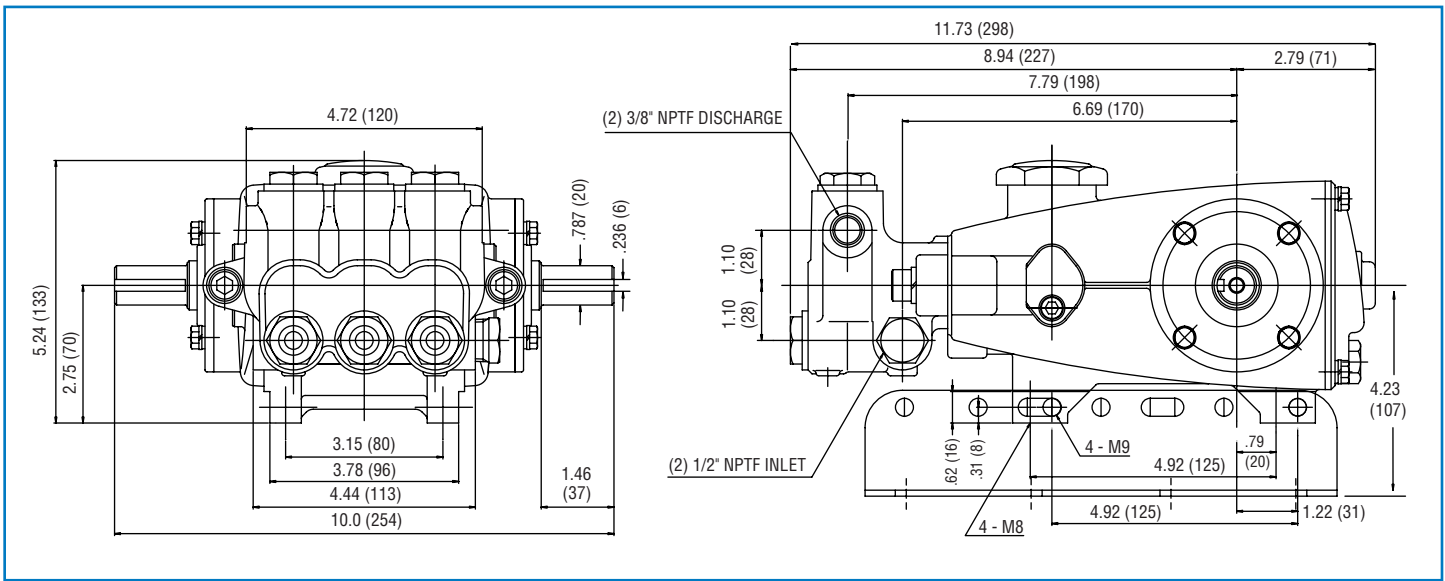

Models 310, 340, 350, 310B, 340B, 350B, 310S, 340S, 350S

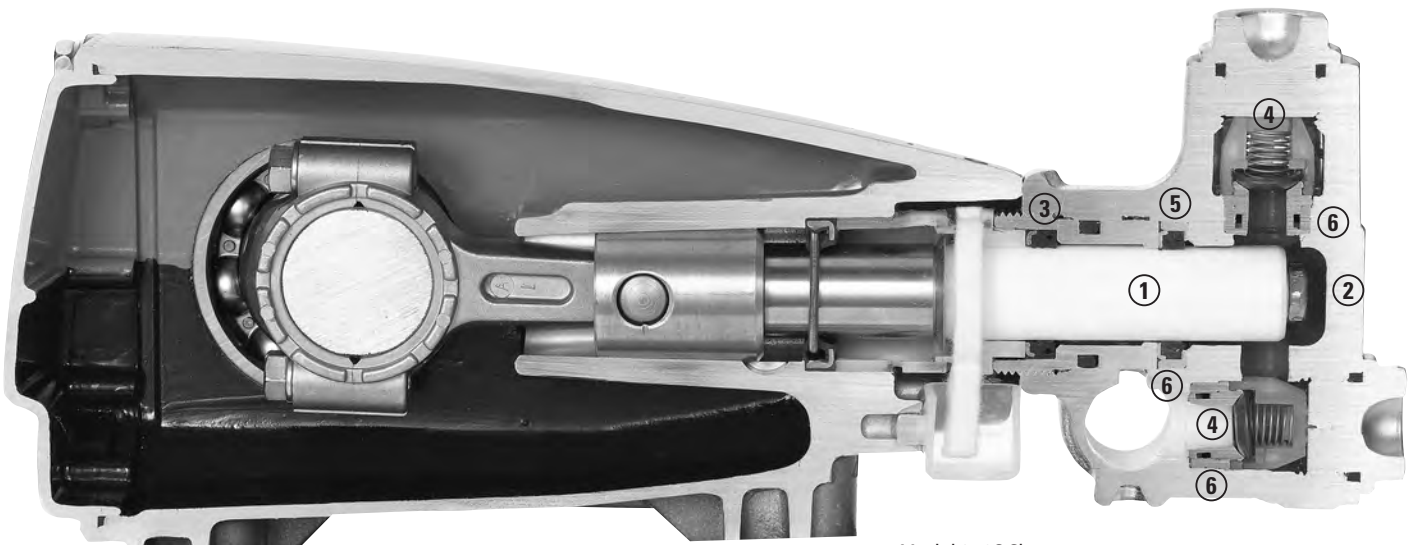

Model 310S Shown

- 1 Special concentric, high-density, polished, solid ceramic **plungers** provide a true wear surface and extended seal life.
- 2 **Manifolds** are a high tensile strength forged brass or special brass for long life, continuous duty and compatibility.
- 3 100% wet **seal** design adds to service life by allowing pumped liquids to cool and lubricate on both sides.
- 4 Stainless steel **valves, seats and springs** provide corrosion-resistance, ultimate seating and extended life.
- 5 Specially formulated, Cat Pump exclusive, **Hi-Pressure Seals** offer unmatched performance and seal life.
- 6 Precision, press-fit, **304 stainless steel sleeves** in both the seal and valve chambers provide extended life (S models only).



CAT PUMPS

1681 - 94TH LANE N.E. MINNEAPOLIS, MN 55449-4324
 PHONE (763) 780-5440 — FAX (763) 780-2958
 e-mail: techsupport@catpumps.com
 www.catpumps.com