

35 Frame Plunger Pumps

Nickel Aluminum
Bronze Models

3507 3517

FEATURES

Superior Design

- Triplex plunger design gives smoother fluid flow.
- V-Packings are completely lubricated and cooled by the fluid being pumped.
- Inlet and discharge valve assemblies interchange for easier maintenance.
- Lubricated Lo-Pressure Seals provide double protection against external leakage.
- Oil bath crankcase assures optimum lubrication in drive-end.
- Close tolerance concentricity of the ceramic plunger maximizes seal life.

Quality Materials

- All stainless steel valves are heat treated and seats are roller burnished for a positive seal and extended valve life.
- Nickel Aluminum Bronze manifolds are strong and corrosion resistant.
- Special concentric, high density, polished, graphite impregnated, soid ceramic plungers are abrasion resistant and result in extended seal life.
- Specially formulated, CAT PUMP exclusive, V-Packings offer unmatched performance and seal life.
- Die cast aluminum crankcase provides high strength, minimum weight and precision tolerance control.
- Chrome-moly crankshaft gives unmatched strength and surface hardness.
- Oversized crankshaft bearings with greater loading capacity means longer bearing life.

Easy Maintenance

- Wet end is easily serviced without entering crankcase, requiring less time and effort.
- Valve assemblies are accessible without disturbing piping, for quick service.
- Preset packings mean no packing gland adjustment is necessary, reducing maintenance costs.

DETERMINING THE PUMP R.P.M. $\frac{\text{Rated G.P.M.}}{\text{Rated R.P.M.}} = \frac{\text{"Desired" G.P.M.}}{\text{"Desired" R.P.M.}}$

DETERMINING THE REQUIRED H.P. $\frac{\text{GPM} \times \text{PSI}}{1460} = \text{Electric Brake H. P. Required}$

DETERMINING MOTOR PULLEY SIZE $\frac{\text{Motor Pulley O.D.}}{\text{Pump R.P.M.}} = \frac{\text{Pump Pulley O.D.}}{\text{Motor R.P.M.}}$

Note: Consult engine manufacturer when using gas or diesel engine. Refer to pump Service Manual for important Inlet Condition Check-List, Start-up Procedure, Tech Bulletins and Pump Maintenance information.

SPECIFICATIONS

U.S. Measure Metric Measure

MODEL 3507

Volume	9.0 GPM	(34 L/M)
Discharge Pressure	100 to 5000 PSI	(7 to 350 BAR)
Bore.....	0.787"	(20 mm)
Discharge Ports (2)	3/4" NPT	(3/4" NPT)

MODEL 3517

Volume	14 GPM	(53 L/M)
Discharge Pressure	100 to 3000 PSI	(7 to 210 BAR)
Bore.....	0.984"	(25 mm)
Discharge Ports (2)	1" NPT	(1" NPT)

COMMON SPECIFICATIONS

Max. Inlet Pressure.....	Flooded to 70 PSI	(Flooded to 4.9 BAR)
RPM	800 RPM	(800 RPM)
Stroke.....	1.890"	(48 mm)
Crankcase Capacity.....	4.2 Qts.	(4 L)
Maximum Fluid Temperature.....	160°F	(71°C)
Inlet Ports (2)	1-1/2" NPT	(1-1/2" NPT)
Pulley Mounting	Either Side	(Either Side)
Shaft Diameter	1.378"	(35 mm)
Weight.....	152 lbs.	(69 kg)
Dimensions.....	24.61" x 18.11" x 9.33"	(625 x 460 x 237 mm)

HORSEPOWER REQUIREMENTS

MODEL	FLOW		PRESSURE						RPM
			PSI 2000	PSI 2500	PSI 3000	PSI 4000	PSI 4500	PSI 5000	
	U.S. GPM	L/M	BAR 140	BAR 175	BAR 210	BAR 280	BAR 310	BAR 350	
3507	9	34	N/A	N/A	N/A	24.7	27.8	30.9	800
	8	30	N/A	N/A	N/A	22.0	24.7	27.5	711
	7	27	N/A	N/A	N/A	19.2	21.7	24.0	622
3517	14	53	19.2	24.0	28.8	N/A	N/A	N/A	800
	12	45	16.5	20.6	24.7	N/A	N/A	N/A	685
	10	38	13.7	17.2	20.6	N/A	N/A	N/A	571

See complete Drive Packages [Incls: Pulleys, Belts, Hubs, Key] Tech Bulletin 03.

"Customer confidence is our greatest asset"

PARTS LIST

ITEM	PART NUMBER				DESCRIPTION	QTY
	3507	MATL	3517	MATL		
● 2	34021	STL	34021	STL	Key (M10x8x70)	1 ●
5	89277	SS	89277	SS	Screw, HH (M8x25)	8
6	15846	S	15846	S	Washer, Spring (M8)	8
7	13534	SS	13534	SS	Washer (M8)	8
8	44542	AL	44542	AL	Cover, Bearing	2
	701138	F	701138	F	Cover, Bearing (Use w/701137, 39, 40, 45, 46)	2
9	44543		44543		Shim, 1/2 Circle	0-2
10	12398	NBR	12398	NBR	O-Ring, Bearing Cover	2
11	13296	NBR	13296	NBR	Seal, Oil, Crankshaft	2
15	29326	STL	29326	STL	Bearing, Roller	2
20	46611	HS	46611	HS	Rod Assembly, Connecting	3
21	44940	STZP	44940	STZP	Washer, Locking, Connecting Rod	3
22	43641	STL	43641	STL	Washer, Connecting Rod (M10.5x1.5)	3
23	88155	STL	88155	STL	Screw (M10x55)	3
25	29325	FCM	29325	FCM	Crankshaft, Dual End	1
32	43211		43211		Cap, Oil Filler	1
33	14177	NBR	14177	NBR	O-Ring, Oil Filler Cap	1
34	44319	STZP	44319	STZP	Bolt, Eye	1
35	701145	AL	701145	AL	Rivet Serial Plate (Use w/701137, 38, 39, 40, 46)	1
36	701146	F	701146	F	Plate Name (Use w/701137, 38, 39, 40, 45)	1
37	43987		43987		Gauge, Bubble Oil	1
38	44428	NBR	44428	NBR	Gasket, Flat Flex.	1
40	89277	SS	89277	SS	Screw, HH (M8x25)	8
41	15849	S	15849	S	Lockwasher, Split (M6)	8
42	19933	S	19933	S	Washer (M6)	8
48	25625	BBCP	25625	BBCP	Plug, Drain (1/4"x11)	1
49	23170	NBR	23170	NBR	O-Ring, Drain Plug	1
50	45936	AL	45936	AL	Cover, Crankcase	1
	701139	F	701139	F	Cover, Crankcase (Use w/701137, 38, 40, 45, 46)	1
51	16612	NBR	16612	NBR	O-Ring, Crankcase Cover	1
● 53	44559	AL	44559	AL	Crankcase	1 ●
	701137	F	701137	F	Crankcase (Use w/ 01138, 39, 40, 45, 46)	1
54	27488	S	27488	S	Pin, Guide	2
56	27790	POP	27790	POP	Pan, Oil	1
57	92519	STZP	92519	STZP	Screw, Sems HHC (M6x16)	2
64	43864	S	43864	S	Pin, Rist	3
65	45118	SSZZ	45118	SSZZ	Rod, Plunger	3
69	29338	S	29338	S	Washer, Oil Seal	3
70	100488	NBR	100488	NBR	Seal, Plunger Rod Oil	3
75	43506	S	43865	S	Slinger, Barrier	3
88	45676	SS	45676	SS	Washer, Keyhole (M16)	3
90	43945	CC	43866	CC	Plunger (M145)	3
95	89779	S	89778	S	Stud, Retainer (M7x123) or (M10x122)	3
96	20184	PTFE	20189	PTFE	Back-up-Ring, Plunger Retainer	3
97	14190	NBR	11345	NBR	O-Ring, Plunger Retainer	3
	14161	FPM	11375	FPM	O-Ring, Plunger Retainer	3
98	44069	SS	44085	SS	Gasket (M7) or (M10)	3
99	44068	SS	44084	SS	Retainer, Plunger (M7) or (M10)	3
100	44119	PVDF	44119	PVDF	Retainer, Seal, 2 Pc.	3
101	44095		44096		Wick	3
104	43875	NBR	43875	NBR	O-Ring, Adapter	3
	44826	FPM	44826	FPM	O-Ring, Adapter	3
105	44073	NAB	44088	NAB	Inlet-Adapter, LPS	3
106	44071	NBR	44086	NBR	LPS w/S-Spg	3
	44381	FPM	45846	FPM	LPS w/S-Spg	3
	44074	SS	44089	SS	Washer, LPS	3
● 110	44206	NAB	44206	NAB	Manifold, Inlet	1 ●
112	11379	NBR	11379	NBR	O-Ring, Inlet Manifold	3
	14183	FPM	14183	FPM	O-Ring, Inlet Manifold	3
118	44585	SS	44585	SS	Screw, HSH (M14x40)	4
123	12391	NBR	12391	NBR	O-Ring, V-Packing Cylinder	3
	13266	FPM	13266	FPM	O-Ring, V-Packing Cylinder	3
124	44075	NAB	44090	NAB	Cylinder, V-Packing	3
126	44076	NAB	44091	NAB	Adapter, Female	3
127	44607	PTFE	44610	PTFE	V-Packing	9/6
128	44077	NAB	44092	NAB	Adapter, Male	3
155	17622	NBR	11379	NBR	O-Ring, V-Packing Spacer	6
	11719	FPM	14183	FPM	O-Ring, V-Packing Spacer	6
156	28675	PTFE	28243	PTFE	Back-up-Ring, V-Packing Spacer	6
157	45597	SS	44093	NAB	Spacer, V-Packing	3
162	21985	PTFE	21985	PTFE	Back-up-Ring, Seat	6
163	26089	NBR	26089	NBR	O-Ring, Seat	6
	11377	FPM	11377	FPM	O-Ring, Seat	6
164	44080	SS	44080	SS	Seat	6
166	44081	SS	44081	SS	Valve	6
167	44082	SS	44082	SS	Spring	6
168	44735	PVDF	44735	PVDF	Retainer, Spring	6
170	44794	SS	44794	SS	Washer, Spring Retainer	6
171	44793	SS	44793	SS	Coil Spring Retainer	6
172	15853	NBR	15853	NBR	O-Ring, Valve Plug	6
	11720	FPM	11720	FPM	O-Ring, Valve Plug	6
173	20224	PTFE	20224	PTFE	Back-up-Ring, Valve Plug	6
174	44795	NAB	44795	NAB	Plug, Valve	6
175	87951	SS	87951	SS	Screw, HSH (M10x30)	36
● 185	46478	NAB	46479	NAB	Manifold, Discharge	1 ●
188	89981	SS	89981	SS	Screw, HHC (M12x70)	8

Replace as a set

EXPLODED VIEW

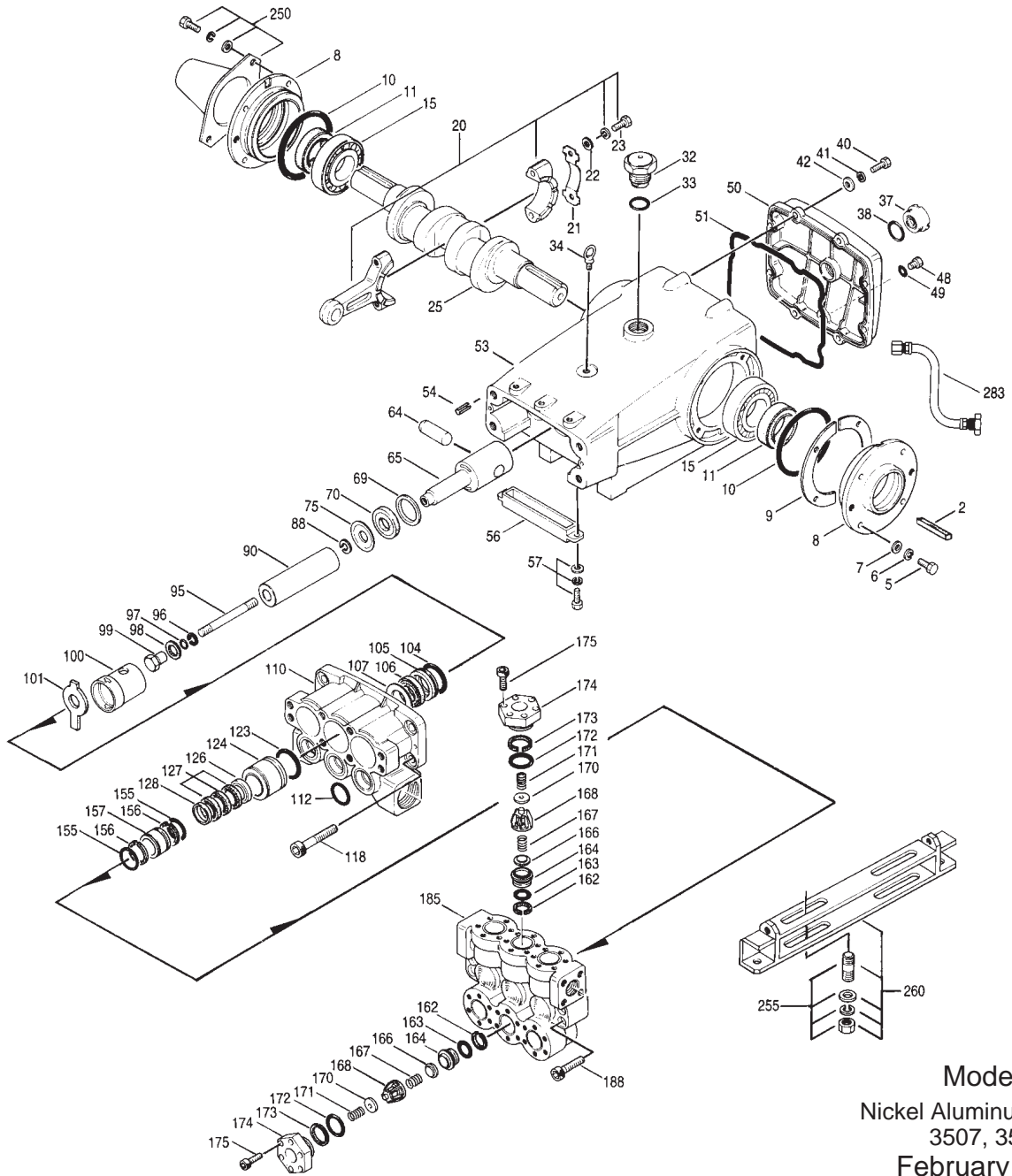

Models
Nickel Aluminum Bronze
3507, 3517
February 1998

● 250	44516	NY	44516	NY	Protector, Shaft, w/2 Screws (89283) (Included with Pump)	1 ●
●	701140	F	701140	F	Protector, Shaft (Use w/701137, 38, 39, 45, 46)	1 ●
● 255	34018	STZP	34018	STZP	Kit, Course, Direct Mount	1 ●
● 260	92674	STZP	92674	STZP	Box Mounting Assy-Course	1 ●
● 275	—	—	—	—	Pulley, Hub & Key [See complete Drive Packages, Tech. 03]	1 ●
● 279	30278	STZP	30278	STZP	Oiler (1/4" NPT - 1 oz.)	3 ●
281	30967	—	30967	—	Glass, Oiler	3 ●
282	10069	—	10069	—	Gasket, Oiler	3 ●
● 283	34334	—	34334	—	Kit, Oil Drain	1 ●
● —	34039	SS	34039	SS	Mount, Stud	1 ●
290	6104/6108	—	6104/6108	—	Gasket, Liquid (.25 oz./1.50 oz.)	1 ●
● 299	814562	NAB	—	—	Complete Head	1 ●
300	31037	NBR	31038	NBR	Kit, Seal (Incls: 97, 104, 106, 112, 123, 127, 155, 156)	1 ●
	33265	FPM	—	—	Kit, Seal (Incls: 97, 104, 106, 112, 123, 127, 155, 156)	1 ●
310	34151	NBR	34151	NBR	Kit, Valve (Incls: 162, 163, 164, 166, 167, 168, 170, 172, 173)	2 ●
	701798	FPM	701798	FPM	Kit, Valve (Incls: 162, 163, 164, 166, 167, 168, 170, 172, 173)	2 ●
● 390	—	—	—	—	C.A.T. (For R.O. or Industrial Applications)	1 ●
● 391	—	—	—	—	Adapter (2 per C.A.T.) (See Data Sheet for complete selection)	2 ●
—	6565.4	—	6565.4	—	Plunger Pump Service Video	1 ●

● Industrial discount. **Bold print part numbers are unique to a particular pump model.** *Italics are optional items.*

C.A.T. highly recommended for pressurized inlet, R.O. and Industrial applications. See Tech Bulletins 03, 24, 36, 41, 52, 53, 68, 69, 74 and 77 for additional information.

MATERIAL CODES (Not Part of Part Number):

AL=Aluminum BB=Brass BBCCP=Brass/Chrome Plated CC=Ceramic FCM=Forged Chrome-moly FPM=Fluorocarbon (Viton®)
HS=High Strength NAB=Nickel Aluminum Bronze NBR=Medium Nitrile (Buna-N) NY=Nylon POP=Polypropylene PTFE=Polytetrafluoroethylene (Teflon®)
PVDF=Fluoroplastic (High Strength) S=304SS SS=316SS SSZZ=316SS/Zamak STL=Steel STZP=Steel/Zinc Plated

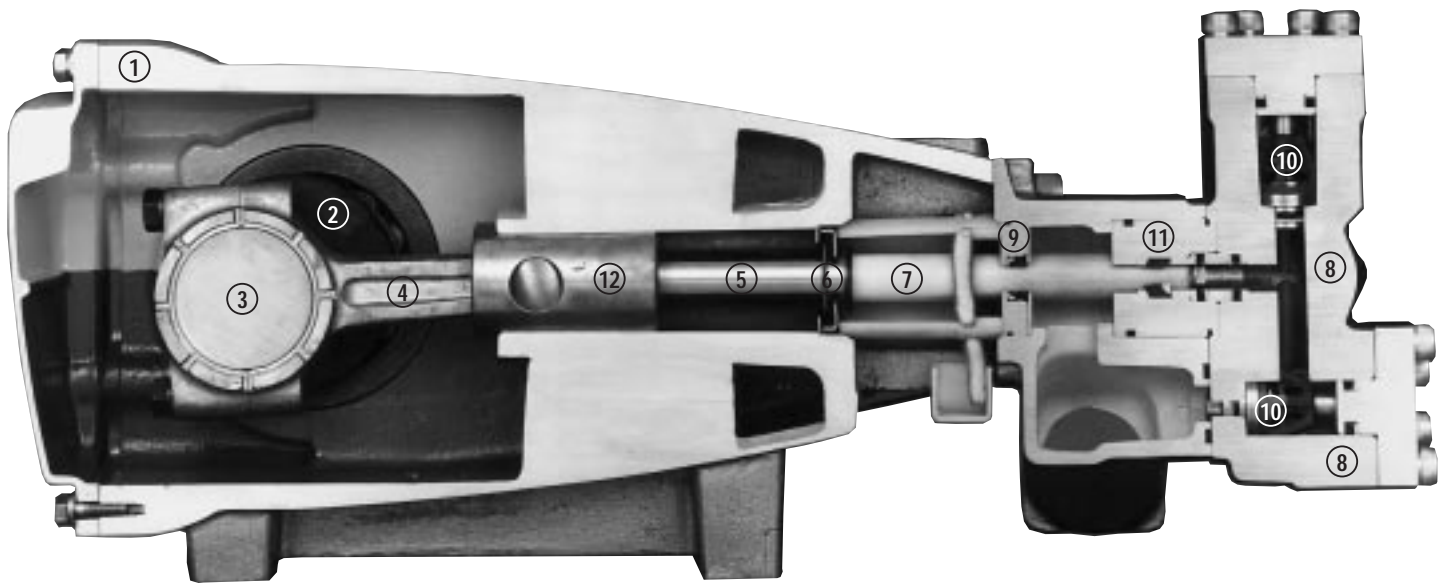
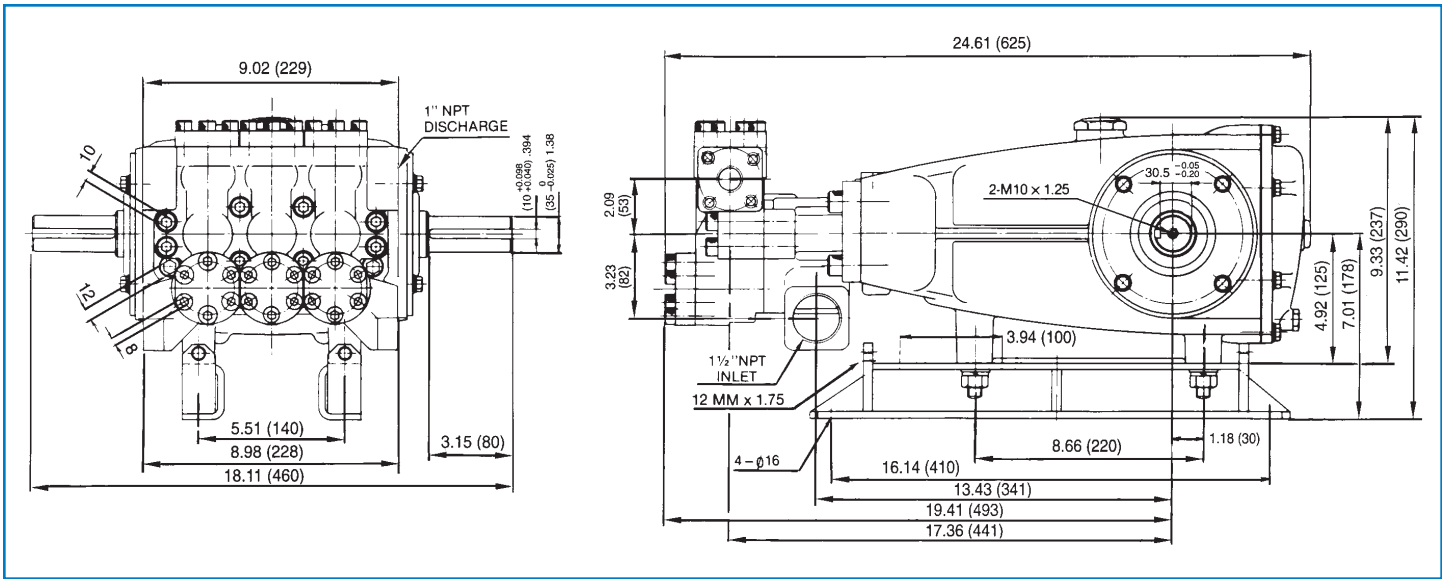

- | | | |
|---|--|---|
| <p>1 Die cast aluminum crankcase means high strength, lightweight, and excellent tolerance control.</p> <p>2 Oversized crankshaft bearings provide extended bearing life and pump performance.</p> <p>3 Chrome-moly crankshaft provides unmatched strength and surface hardness for long life.</p> <p>4 Matched oversized high strength connecting rods are noted for superior strength and bearing quality.</p> <p>5 Special stainless steel plunger rods with high strength crossheads for longevity and corrosion resistance.</p> | <p>6 The stainless steel slinger provides back-up protection for the crankcase seal, keeping pumped fluids out of the crankcase.</p> <p>7 Special concentric, high density, polished, graphite impregnated, solid ceramic plungers are abrasion resistant and result in extended seal life.</p> <p>8 Manifolds are high tensile strength nickel aluminum bronze for long term, continuous duty.</p> | <p>9 100% wet seal design adds to service life by allowing pumped fluids to cool and lubricate on both sides.</p> <p>10 Stainless steel valves, seats and springs provide corrosion-resistance, positive seating and long life.</p> <p>11 Specially formulated, CAT PUMP exclusive, V-Packings offer unmatched performance and seal life.</p> <p>12 Crossheads are 360° supported for uncompromising alignment.</p> |
|---|--|---|

Products described hereon are covered by one or more of the following U.S. patents 3558244, 3652188, 3809508, 3920356, 3930756 and 5035580

Feb 1998 11710

World Headquarters

CAT PUMPS

1681 - 94th Lane N.E. Minneapolis, MN 55449-4324

Phone (612) 780-5440 — FAX (612) 780-2958

e-mail: sales@catpumps.com

www.catpumps.com

International Inquiries

FAX (612) 785-4443

e-mail: intlsales@catpumps.com



The Pump with "Nine Lives"

CAT PUMPS (U.K.) LTD.

1 Fleet Business Park, Sandy Lane, Church Crookham, Fleet

Hampshire GU13 0BF, England

Phone Fleet 44 1252-622031 — Fax 44 1252-626655

N.V. CAT PUMPS INTERNATIONAL S.A.

Heiveldkens 6A, 2550 Kontich, Belgium

Phone 32-3-450.71.50 — Fax 32-3-450.71.51

e-mail: cpi@catpumps.be

CAT PUMPS DEUTSCHLAND GmbH

Buchwiese 2, D-65510 Idstein, Germany

Phone 49 6126-93030 — Fax 49 6126-930333

e-mail: catpumps@t-online.de