

Electric Motor or Gas Engine must be purchased separately. (Unloader and by-pass hose included with pump)

Direct-Drive Plunger Pumps

Electric Models **2SFX20ES**
2SFX22ES, 2SFX25ES
2SFX30ES, 2SFX30GES

Gas Models **2SFX25GZ**
2SFX30GS, 2SFX30GZ

PUMP FEATURES

- Triplex design provides smoother liquid flow.
- Ultimate portability—less than 12 pounds—less than 10" long.
- Unique spring loaded inlet valves and the flow through ceramic plunger provides a smooth steady flow.
- Your choice of motorized unit or hollow shaft pump only for direct mounting to gas or electric motor.
- Regulating Unloader with By-pass Hose is standard on each 2SFX pump to assure system pressure control and pump protection.
- Special HT and FPM seals and FPM o-rings for liquid compatibility.

COMMON PUMP SPECIFICATIONS

Inlet Pressure Range.....	Flooded to 75 psi	(Flooded to 5.25 bar)
Bore	0.708"	(18 mm)
Max. Liquid Temperature.....	160°F	(71°C)
Above 130°F call CAT PUMPS for inlet conditions and elastomer recommendations.		
Crankcase Capacity.....	11.83 oz.	(.35 l)
Inlet Ports (1).....	3/8" NPTF	(3/8" NPTF)
Discharge Ports (2).....	3/8" NPTF	(3/8" NPTF)
By-pass Port.....	1/4" NPTF	(1/4" NPTF)
Weight (Pump Only).....	11.83 lbs.	(4.8 kg)
Dimensions (Pump Only)	9.13 x 6.65 x 6.50"	(232 x 169 x 165mm)

SPECIFICATIONS

	U.S. Measure	Metric Measure	U.S. Measure	Metric Measure
MODEL	2SFX20ES		2SFX22ES	
Flow.....	2.0 gpm	(7.6 lpm)	2.2 gpm	(8.3 lpm)
Max. Discharge Pressure.....	2000 psi	(140 bar)	2000 psi	(140 bar)
Max. RPM.....	3450 rpm	(3450 rpm)	3450 rpm	(3450 rpm)
Stroke.....	0.122"	(3.1 mm)	0.132"	(3.35 mm)
MODEL	2SFX25ES		2SFX30ES	
Flow.....	2.0 gpm	(7.6 lpm)	3.0 gpm	(11.4 lpm)
Max. Discharge Pressure.....	2000 psi	(140 bar)	1500 psi	(105 bar)
Max. RPM.....	3450 rpm	(3450 rpm)	3450 rpm	(3450 rpm)
Stroke.....	150"	(3.8 mm)	0.177"	(4.5 mm)
MODEL			2SFX30GES	
Flow.....			3.0 gpm	(11.4 lpm)
Max. Discharge Pressure.....			2000 psi	(140 bar)
Max. RPM.....			3450 rpm	(3450 rpm)
Stroke.....			0.189"	(4.8 mm)
MODEL	2SFX25GZ		2SFX30GS	
Flow.....	2.5 gpm	(9.5 lpm)	3.0 gpm	(11.4 lpm)
Max. Discharge Pressure.....	2500 psi	(175 bar)	2000 psi	(140 bar)
Max. RPM.....	3450 rpm	(3450 rpm)	3450 rpm	(3450 rpm)
Stroke.....	0.169"	(4.3 mm)	0.189"	(4.8 mm)
MODEL			2SFX30GZ	
Flow.....			3.0 gpm	(11.4 lpm)
Max. Discharge Pressure.....			2500 psi	(175 bar)
Max. RPM.....			3450 rpm	(3450 rpm)
Stroke.....			0.189"	(4.8 mm)

⚠ CAUTIONS AND WARNINGS

All High Pressure Systems require a primary pressure regulating device (i.e. regulator, unloader) and a secondary pressure relief device (i.e. pop-off valve, relief valve). Failure to install such relief devices could result in personal injury or damage to pump or property. CAT PUMPS does not assume any liability or responsibility for the operation of a customer's high pressure system.

Read all CAUTIONS and WARNINGS before commencing service or operation of any high pressure system. The CAUTIONS and WARNINGS are included in each service manual and with each Accessory Data sheet. CAUTIONS and WARNINGS can also be viewed online at www.catpumps.com/cautions-warnings or can be requested directly from CAT PUMPS.

WARRANTY

View the Limited Warranty on-line at www.catpumps.com/warranty.

ES = **Electric 5/8"** hollow shaft with bolt mount, NEMA 56C

GES = **Electric 3/4"** hollow shaft with bolt mount.

GS, GZ = **Gas 3/4"** hollow shaft with bolt mount and adapter.

Gas Mounting Flange: SAE J609, Flange A, Extension 3 (3/4" Ø)

Shaft Length: 2.296, Pilot Ø= 1 5/8", B.C. Ø= 3 5/8", Thread= 5/16"- 24 UNC Tap

Refer to pump **Service Manual** for repair procedures and additional technical information.

EXPLODED VIEW

April 2011

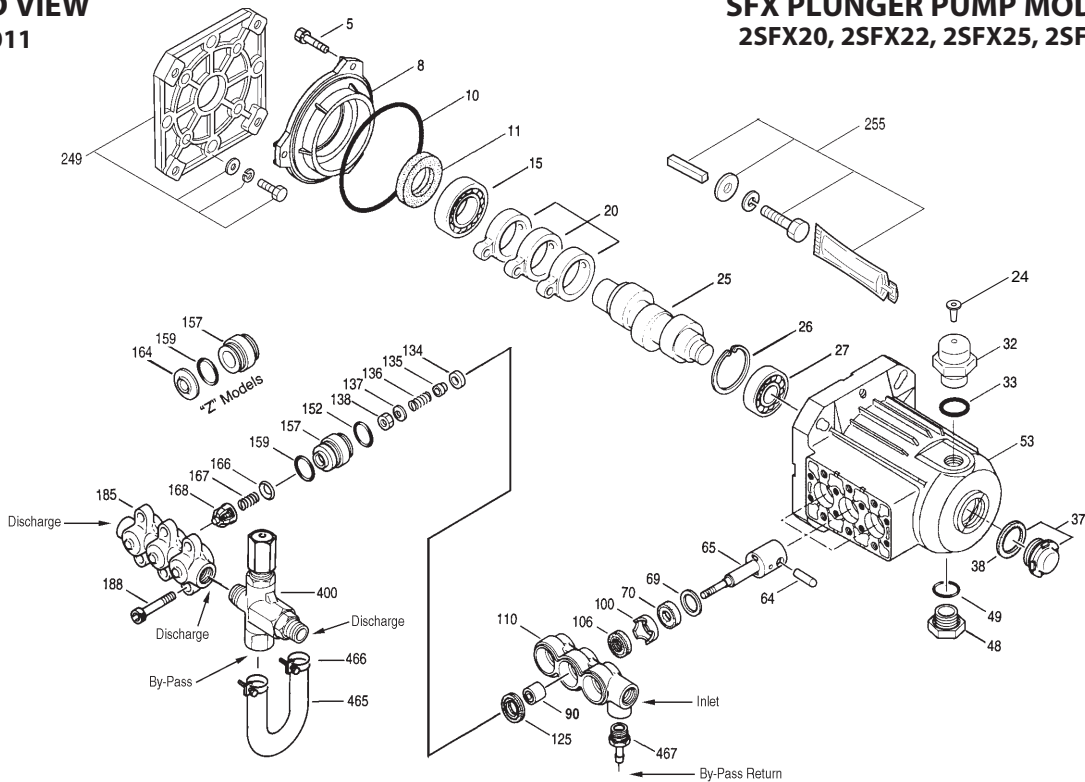

SFX PLUNGER PUMP MODELS

2SFX20, 2SFX22, 2SFX25, 2SFX30

PARTS LIST

ITEM	P/N	MATL	DESCRIPTION	MODEL USED	QTY	ITEM	P/N	MATL	DESCRIPTION	MODEL USED	QTY	
5	549360	STCP R	Screw, HH (M6x14) (See Tech Bulletin 092)	All Models	3	152	† 26089	NBR	O-Ring, Adapter - 80D	All Models	3	
8	547153	AL	Cover, Bearing, Inner (See Tech Bulletin 092)	All Models	1		11377	FPM	O-Ring, Adapter - 80D	All Models	3	
10	14041	NBR	O-Ring, Bearing Cover-70D (See Tech Bulletin 092)	All Models	1	157	45859	BB	Adapter, Discharge, Seat	All Models	3	
11	55337	NBR	Seal, Oil - 70D (See Tech Bulletin 092)	All Models	1		44878	BB	Spacer, Discharge, Valve	2SFX25GZ, 30GZ	3	
15	14488	STL	Bearing, Ball, Inner	All Models	1	159	† 26089	NBR	O-Ring, Adapter - 80D	All Models	3	
20	547046	TNM	Rod, Connecting	All Models	3		11377	FPM	O-Ring, Adapter - 80D	All Models	3	
24	549608	LPDE	Plug, Oil Cap (Remove before Start-Up)	All Models	1	164	44881	S	Seat	2SFX25GZ, 30GZ	3	
25	46109	FCM	Crankshaft, 3450 RPM, 5/8", 3.1mm	2SFX20ES	1	166	43723	S	Valve	All Models	3	
	44929	FCM	Crankshaft, 3450 RPM, 5/8", 3.35mm	2SFX22ES	1	167	541062	S	Spring	All Models	3	
	45844	FCM	Crankshaft, 3450 RPM, 5/8", 3.8mm	2SFX25ES	1	168	44565	PVDF	Retainer, Spring	All Models	3	
	542967	FCM	Crankshaft, 3450 RPM, 3/4", 4.3mm	2SFX25GZ	1	185	44879	BB	Manifold, Discharge	All Models	1	
	44931	FCM	Crankshaft, 3450 RPM, 5/8", 4.5mm	2SFX30ES	1	188	126762	STCP R	Screw, HSH (M8x75)	All Models	6	
	546334	FCM	Crankshaft, 3450 RPM, 3/4", 4.8mm [12/01]2SFX30GS,GZ	12/01]2SFX30GS,GZ	1	249	30520	—	Assy, Adapter Mount, Gas	All Gas Models	1	
26	12385	STL	Ring, Retaining	All Models	1	255	30517	STZP	Assy, Bolt Mount	All Models	1	
27	15710	STL	Bearing, Ball, Outer	All Models	1	285	80228	STL	Screw (M8-1.25x80) (Motor Removal)	All Models	2	
32	547961	RTP	Cap, Oil Filler w/O-Ring	All Models	1	300	34053	NBR	Kit, Seal	All Models	1	
33	14179	NBR	O-Ring, Oil Filler Cap - 70D	All Models	1				(Incls: 106,125,152,159)			
37	92241	—	Gauge, Oil, Bubble w/Gasket	All Models	1		33953	HT	Kit, Seal, Hi-Temp	All Models	1	
38	44428	NBR	Gasket, Oil Gauge - 80D	All Models	1				(Incls: 106,125,134,152,159)			
48	44842	NY	Plug, Drain (1/2" NPT)	All Models	1		33453	FPM	Kit, Seal	All Models	1	
49	14179	NBR	O-Ring, Drain Plug - 70D	All Models	1				(Incls: 106,125,152,159)			
53	547285	AL	Crankcase (See Tech Bulletin 092)	All Models	1	310	34056	NBR	Kit, Valve	All except GZ	1	
64	16948	CM	Pin, Crosshead	All Models	3				(Incls: 152,157,159,166,167,168)			
65	540073	SZZ	Rod, Plunger, Unchromed	2SFX20,22,25,30,35	3		34052	NBR	Kit, Valve	2SFX25GZ, 30GZ	1	
	542958	SHS	Rod, Plunger	2SFX25GZ,30GZ	3				(Incls: 152,159,164,166,167,168)			
69	126259	STCP R	Washer (M24)	All Models	3	311	34668	NBR	Kit, Inlet Valve	All Models	1	
70	25461	NBR	Seal, Oil	All Models	3				(Incls: 134-137,152,159)			
90	45847	CC	Plunger (M18x14)	All Models	3	352	44050	STZP	Gauge, Oil, Removal Tool	All Models	1	
100	44869	PVDF	Retainer, Seal	All Models	3	400	7500XS	BB	Unloader, Regulating	Std. 2SFX Models	1	
106	† 44876	NBR	Seal, LPS w/S-Spg	All Models	3		—	7625	BB	Unloader, Regulating	2SFX25GZ, 30GZ	1
	545192	FPM	Seal, LPS w/SS-Spg	All Models	3	467	45868	BB	Barb, Pump Inlet (1/4" Hose x 1/4" NPT)	All Models	1	
110	44874	BB	Manifold, Inlet	All Models	1		—	6575	—	All Models	1	
125	43245	SNG	Seal, HPS w/S	All Models	3		—	6107	—	All Models	1	
	46652	HT	Seal, HPS, "Hi-Temp", 2-Pc w/S-Support	All Models except GZ	3				(Fill to specified crankcase capacity prior to start-up)			
134	45854	S	Valve, Inlet	All Models	3							
	33873	NY	Valve, Inlet, Hi-Temp	All Models	3							
135	549520	S	Spacer	All Models	3							
136	44872	S	Spring, Inlet	All Models	3							
137	88575	S	Washer, Conical (M6)	All Models	3							
138	81240	SS	Nut, Hex (M6)	All Models	3							

Bold Part Numbers are unique to a particular pump model. Italics are optional items. [] Date of latest production change.

† Production parts are different than service parts. R Components comply with RoHS Directive.

See Tech Bulletins 002, 024, 036, 043, 055, 064, 065, 070, 073, 074, 083, 091 and 092 for additional information.

Effective with 1/90 Mfg. date 45853, 14036, 44861, 92519 have been replaced with new one piece crankcase.

Note: Discard Key which may come standard with most motors and engines and **use only the key included in this kit.**

MATERIAL CODES (Not Part of Part Number): AL=Aluminum BB=Brass CC=Ceramic CM=Chrome-moly FCM=Forged Chrome-moly FPM=Fluorocarbon

HT=Hi-Temp (EPDM Alternative) NBR=Medium Nitrile (Buna-N) NY=Nylon PVDF=Polyvinylidene Fluoride RTP=Reinforced Composite S=304SS SHS=304SS/High Strength

SNG=Special Blend (Buna) SS=316SS STL=Steel STCP=Steel/ Chrome-Plated STZP=Steel/Zinc Plated SZZ=304SS/Zamak TNM=Special High Strength

Center raised pilot guide on the **Adapter Plate** assures proper alignment of pump and engine. Before mounting pump onto engine inspect engine for **recessed seal and bearing guide** to permit adapter to completely seat into recess and four bosses to be flush with engine face.

7500XS UNLOADER FOR "ES, GS" PUMP MODELS

Specifications	U.S. Measure	Metric Measure
Flow.....	0.5-6.0 gpm	(2-23 lpm)
PSI Range.....	100-2000 psi	(7-140 bar)
Max. Temperature.....	190°F	(88°C)
Inlet Port - Rear.....	3/8" NPTM	(3/8" NPTM)
Discharge Port - Front.....	3/8" NPTM	(3/8" NPTM)
By-pass Port - Barb.....	1/4" NPT	(1/4" NPT)
Weight.....	14 oz.	(0.40 kg)
Dimensions.....	3.0 x 1.0 x 4.25"	(76 x 25 x 108 mm)

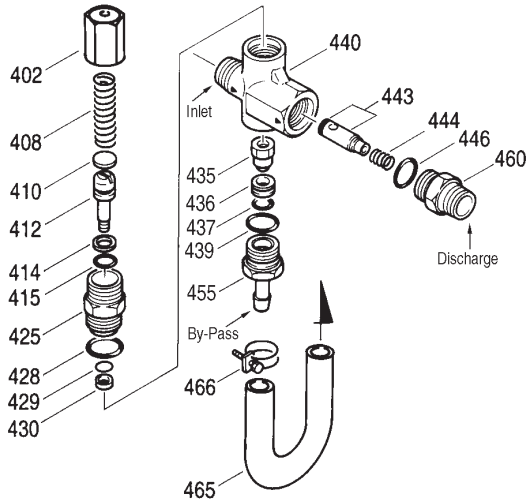

PARTS LIST

ITEM	P/N	MATL	DESCRIPTION	QTY
402	540081	BB	Cap, Adjusting	1
404	31047	BB	Nut, Lock (Not Shown)	1
408	32094	STZP R	Spring, Pressure	1
410	107672	BB	Retainer, Spring	1
412	45694	S	Stem, Piston (M5)	1
414	20184	PTFE	Back-up-Ring, Piston Stem	1
415	14190	NBR	O-Ring, Piston Stem - 70D	1
	14161	FPM	O-Ring, Piston Stem - 70D	1
425	107673	BB	Retainer, Piston	1
428	13969	NBR	O-Ring, Retainer- 70D	1
	14320	FPM	O-Ring, Retainer - 70D	1
429	14759	NBR	O-Ring, Body	1
	14160	FPM	O-Ring, Body - 80D	1
430	107675	PTFE	Back-up-Ring, Body	1
435	45696	BB	Valve and Ball Assembly (M5)	1
436	107680	S	Seat	1
437	13963	NBR	O-Ring, Seat - 70D	1
	14303	FPM	O-Ring, Seat - 70D	1
439	13969	NBR	O-Ring, By-pass Fitting- 70D	1
	14320	FPM	O-Ring, By-pass Fitting - 70D	1
440	—	BB	Body	1
443	541060	BB	Valve, Check w/O-Ring	1
444	45924	S	Spring	1
446	13969	NBR	O-Ring, Discharge Fitting - 70D	1
	14320	FPM	O-Ring, Discharge Fitting - 70D	1
455	45865	BB	Barb, By-pass Fitting	1
460	107681	BB	Fitting, Discharge (3/8" NPTM)	1
465	46140	—	By-pass Hose (5-1/2"x1/4")	1
	45983	—	By-pass Hose (8-1/2"x1/4") (UMS)	1
466	45929	STZP	Clamp, Hose	2
468	32097	NBR	Kit, O-Ring	1
			(Incls: 414,415,428,429,430,437,439,446)	
	31627	FPM	Kit, O-Ring	1
			(Incls: 414,415,428,429,430,437,439,446)	
469	7192	BB	Injector Chemical (1.8 mm) Adjustable	1
	7193	BB	Injector Chemical (2.1 mm) Adjustable	1

Italics are optional items. R Components comply with RoHS Directive.

MATERIAL CODES (Not Part of Part Number): BB=Brass FPM=Fluorocarbon
NBR=Medium Nitrile (Buna-N) PTFE=Pure Polytetrafluoroethylene
S=304SS STZP=Steel/Zinc Plated

OPERATION

A Regulating Unloader comes with each 2SFX pump to provide system pressure regulation and pump protection.

For MAXIMUM SUCTION capability, Regulating Unloader should be remounted on discharge manifold, OPPOSITE from pump inlet port.

Standard Units with return of by-pass back to the inlet of the pump should have a Thermo Valve in the by-pass line.

By-pass HOSE ASSEMBLY is designed for cold water or ambient temperature operation. DO NOT EXCEED 6 MINUTES in by-pass

7625 UNLOADER FOR "GZ" PUMP MODELS

Specifications	U.S. Measure	Metric Measure
Flow.....	0.5-7.8 gpm	(2-30 lpm)
PSI Range.....	100-2500 psi	(7-175 bar)
Max. Temperature.....	194°F	(90°C)
Inlet Port.....	3/8" BSPM	(3/8" BSPM)
Discharge Port.....	3/8" BSPF	(3/8" BSPF)
By-pass Port.....	3/8" BSPF	(3/8" BSPF)
Auxiliary Port.....	1/4" BSPF	(1/4" BSPF)
Weight.....	19.5 oz.	(0.55 kg)
Dimensions.....	3.2 x 1.5 x 4.7"	(81 x 38 x 119.4 mm)

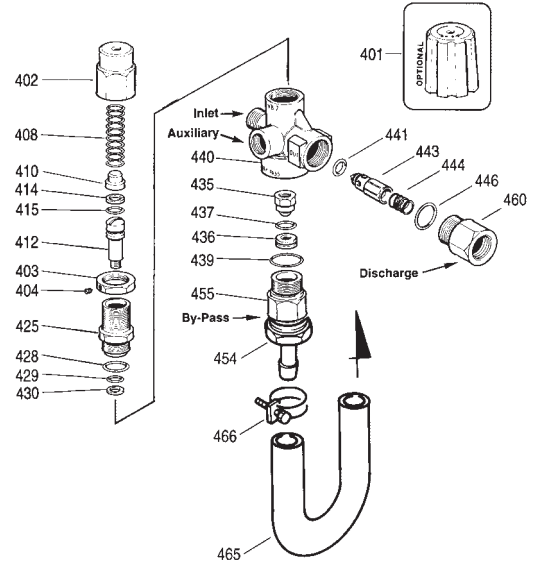

PARTS LIST

ITEM	P/N	MATL	DESCRIPTION	QTY
401	32088	NY	Handle, Black	1
402	33859	BB	Cap, Adjusting	1
403	33857	BB	Nut, Lock (M18x1)	1
404	33061	STZP	Screw, Set (M4x4)	1
408	32094	STZP R	Spring, Pressure	1
410	32819	STZP	Retainer, Spring	1
412	33860	S	Stem, Valve	1
414	33278	PTFE	Back-up-Ring, Stem	1
415	—	NBR	O-Ring, Stem	1
425	33861	BB	Retainer, Piston	1
428	33043	NBR	O-Ring, Retainer	1
429	—	NBR	O-Ring, Body	1
430	33276	PTFE	Back-up-Ring, Body	1
435	33853	SSS	Valve and Ball Assembly (M6)	1
436	33806	NBR	Seat, w/O-Ring	1
437	—	NBR	O-Ring, Seat	1
439	—	NBR	O-Ring, By-pass Fitting - 85D	1
440	—	BB	Valve Body	1
441	—	NBR	O-Ring, Flow Balancer	1
443	33852	BB	Valve, Check	1
444	33843	S	Spring	1
446	—	NBR	O-Ring, Discharge Fitting	1
454	33865	BB	Barb, By-pass (3/8" NPTx1/4)	1
455	33846	BB	Fitting, By-pass (3/8" BSP)	1
460	33847	BB	Fitting, Discharge (3/8" BSP)	1
465	46140	—	By-pass Hose (5-1/2"x1/4")	1
466	—	STZP	Clamp, Hose	2
468	33098	NBR	Kit, O-Ring	1
			(Incls: 414,415,428,429,430,437,439,441)	
469	7224	BB	Injector Chemical	1

Italics are optional items. R Components comply with RoHS Directive.

MATERIAL CODES (Not Part of Part Number): BB=Brass
NBR=Medium Nitrile (Buna-N) NY=Nylon PTFE=Pure Polytetrafluoroethylene
S=304SS SSS=416SS STZP=Steel/Zinc Plated

operation. Excessive temperatures will cause premature wear or damage to the pump and VOID THE WARRANTY.

Hi-Temp Units with special Hi-Temp seals do not use the Thermo Valve. Use optional Dual Pressure Switches and Mechanical Relay in Auto Shut Off Kits 34870 and 34871.

If unit is INFREQUENTLY USED OR PERIODICALLY STORED, seals may become dry. UNDER SUCTION FEED, system must be PURGED BEFORE OPERATION (system liquid must flow through the pump without discharge restriction) to assure full system pressure is reached.

MOTOR SPECIFICATIONS

Model 8050		Model 8055		★ Model 8060		Model 8125	
Horsepower.....	1.5	Horsepower.....	3.0	Horsepower.....	1.5	Horsepower.....	2.5
Shaft Diameter.....	5/8"	Shaft Diameter.....	●3/4"	Shaft Diameter.....	5/8"	Shaft Diameter.....	5/8"
Max. Volts.....	115/230	Max. Volts.....	208/230	Max. Volts.....	115/230	Max. Volts.....	110/220, 115/230
FULL LOAD AMPS.....	12.1	FULL LOAD AMPS.....	15.2/13.6	FULL LOAD AMPS.....	14.0/7.0	FULL LOAD AMPS.....	23.6/11.8, 21/11.5
RPM.....	3450	RPM.....	3450	RPM.....	1725	RPM.....	1450, 1750
Weight.....	32.1 lbs.	Weight.....	46.3 lbs.	Weight.....	40 lbs.	Weight.....	52.9 lbs.
Phase.....	Single	Phase.....	Single	Phase.....	Single	Phase.....	Single
Frame Size.....	56-C TEFC	Frame Size.....	56-C TEFC	Frame Size.....	56-C TEFC	Frame Size.....	50/60
Service Factor.....	1.15	Service Factor.....	1.15	Service Factor.....	1.2	Service Factor.....	56-C TEFC
		● Use 3/4" shaft size motor with GES Pumps.		★ Use to reduce flow by 50% on standard electric models			1.0, 1.2
★ Model 8052		Model 8057		★ Model 8062		Common Motor Specifications	
Horsepower.....	2.0	Horsepower.....	5.0	Horsepower.....	2.0	Max. Ambient Temp.....	104°F
Shaft Diameter.....	5/8"	Shaft Diameter.....	●3/4"	Shaft Diameter.....	5/8"	Hertz.....	60 Hz
Max. Volts.....	115/230	Max. Volts.....	230	Max. Volts.....	115/230	Capacitor Start.....	Yes
FULL LOAD AMPS.....	17.0/9.2-8.5	FULL LOAD AMPS.....	22.0	FULL LOAD AMPS.....	17.0/8.5	Thermal Overload-Manual Reset....	Yes
RPM.....	3450	RPM.....	3450	RPM.....	1725	Note: Motor Start-Up AMPS may vary, then settle within	
Weight.....	32.5 lbs.	Weight.....	40 lbs.	Weight.....	43.7 lbs.	FULL LOAD AMPS rating after initial run in time.	
Phase.....	Single	Phase.....	Single	Phase.....	Single	★★ Before mounting pump on motor, apply P.N.	
Frame Size.....	56-C TEFC	Frame Size.....	56-C OPEN DRIP	Frame Size.....	56-C TEFC	6106 Antiseize Lubricant to pump shaft.	
Hertz.....	60	Service Factor.....	1.15	Service Factor.....	1.15	★★ Refer to Tech Bulletin 055 for instructions on	
Service Factor.....	1.15	● Use 3/4" shaft size motor with GES Pumps.		★ Use to reduce flow by 50% on standard electric models		removing pump from gas engine or electric	
						motor.	

For warranty consideration contact CAT PUMPS for the local **Authorized Service Center**. If you are uncertain as to the cause of failure (Pump or Motor), secure **Returned Goods Authorization number** and return complete assembly **PREPAID** to CAT PUMPS for evaluation.

ELECTRIC HORSEPOWER REQUIREMENTS						
ES, GES Flow		Pressure				Pump rpm
		psi 1000	psi 1200	psi 1500	psi 2000	
gpm	lpm	bar 70	bar 85	bar 105	bar 140	
2.2	8.3	1.5	1.8	2.3	3.0	3450
3.0	11.4	2.1	2.5	3.1	4.2	3450
3.5	13.2	2.4	2.9	3.6	4.8	3450
GS, GZ Flow		psi 1200	psi 1500	psi 2000	psi 2500	Pump rpm
		bar 85	bar 105	bar 140	bar 175	
gpm	lpm					
2.5	9.5	2.1	2.6	3.4	4.3	3450
3.0	11.4	2.5	3.1	4.2	5.2	3450

DETERMINING THE REQUIRED H.P.		
$\frac{\text{gpm} \times \text{psi}}{1460}$	=	Electric Brake H.P. Required

Consult your engine supplier for proper gas or diesel engine selection.

2SFX DIMENSIONAL DRAWING

MODEL	8050	8052	8055	8057	8060	8062	8125
Dimension A	18.2	18.2	20.0	18.7	18.7	19.2	19.1
Dimension B	11.3	11.3	13.1	11.8	11.8	12.3	12.2
Dimension C	8.4	8.4	8.3	9.0	8.1	8.1	9.6
Dimension D	9.5	9.5	9.5	9.5	9.5	9.5	9.7

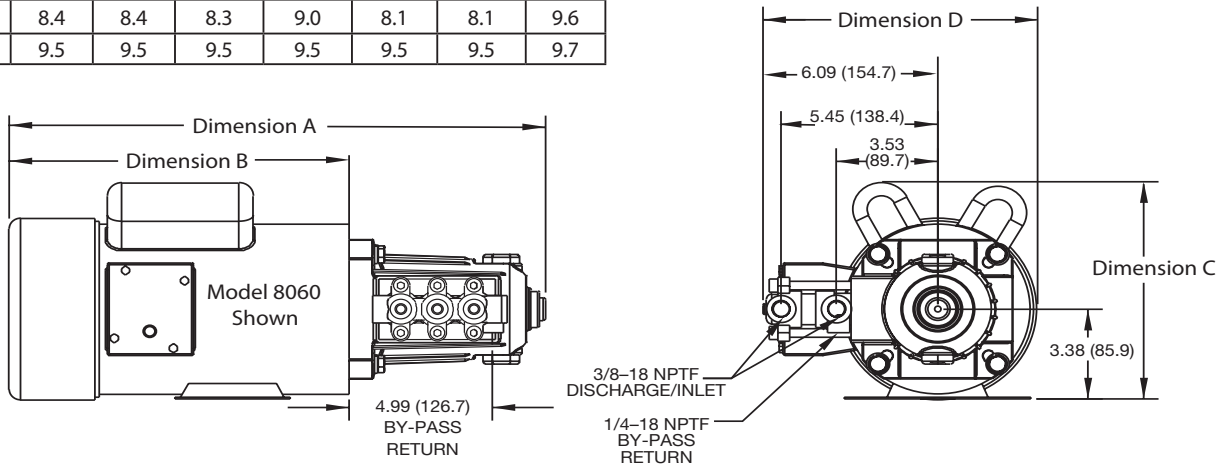

CAT PUMPS
 1681 - 94TH LANE N.E. MINNEAPOLIS, MN 55449-4324
 PHONE (763) 780-5440 — FAX (763) 780-2958
 e-mail: techsupport@catpumps.com
 www.catpumps.com