



2K Series Stainless Steel Submersible Pumps

Models 2K100-2K405

FEATURES

- 304SSL construction offers corrosion resistance and increases operating life over typical cast iron models.
- Unique bulge formed components eliminates harsh radius and welds and provides greater efficiency and durability.
- Lubricated double mechanical seal offers dependable performance with a variety of liquids.
- Air filled, continuous-duty motors for reliable, long term operation.
- Single phase motor features permanent split capacitor and thermal protection with automatic reset for added protection and extend motor life.
- Versatile, reliable operation whether fully or partially submerged.
- Multiple sizes from 1/2 to 2 hp offers application flexibility.
- Sealed float switch for automatic operation.

Quality Materials

- Casing is 304SSL for durability over traditional cast iron.
- Semi-open impeller is 304SSL on all models for long life, durability and economy.
- Shaft is 304SSL for dependable, long life.
- Motor frame is 304SSL for dependability.
- Fasteners are all 304SS for durability.
- Shaft Seals are special blend NBR and FPM for compatibility and long life.
- Sealed Bearings for longer life.

SPECIFICATIONS

	U.S. Measure
Flow Rangeup to 180 GPM
Pressure Rangeup to 19.5 PSI
up to 46 Ft. Head
RPM3450 RPM
Discharge Fitting2" NPT
Motor Phase	SingleClass F, 115V, 208-230V
	Three.....Class F, 208-230V, 460V
Cycle60 Hz
Cable Length	1 PH[Gauge AWG 14/16, UL/CSA 3-Prong] 25 Ft.
	3 PH [Gauge AWG 16, UL/CSA] 25 Ft.
Float OperationManual or Automatic
Maximum Starts/Hour20
Maximum Temperature (Continuous) 104°F
	(Intermittent) 140°F
Maximum Solids Diameter2"
Weight (see charts)32-52 lbs.
Dimensions (see charts)	
	Length.....19.13-24.0"
	Diameter9.0"

CAPACITY IN GALLONS PER MINUTE (GPM)	
MODEL	FEET OF HEAD
	8 9 10 12 14 16 18 21 24 27 30 32 35 40 46
2K100-105	88 83 78 68 57 45 31 8
2K200-205	100 88 76 64 45 25 8
2K302-305	120 113 105 97 84 69 52 30 8
2K403-405	180 177 171 165 158 152 141 130 118 105 96 81 52 8

“Customer confidence is our greatest asset”

GENERAL SAFETY AND OPERATION

1. Use with the proper electrical receptacle. On single phase models cord is supplied with a grounding type, 3-prong plug.
NOTE: DO NOT USE GROUNDING ADAPTER.
2. Do not use if outer covering of cord becomes excessively cut or worn.
3. Each pump comes with a built-in handle for lifting. For added convenience, the 899045 25 ft. marine rope can be attached to the handle.

WARNING

Do not lift with power cord. This can cause damage to the connection and result in shock or serious injury.

4. Continued cycling on and off is an indication the motor is in overload. Make certain the pump is level and adequately submerged in liquid.

NOTE: CONTINUED OPERATION WITH EXCESSIVE CYCLING WILL OVERHEAT AND BURN OUT MOTOR.

5. All automatic models come with a Float Switch to shut-off unit when liquid level drops below safe operation. For field retro-fit, the 899080 [115V] or 899081 [230V] Float Switch can be added to automate the manual units.

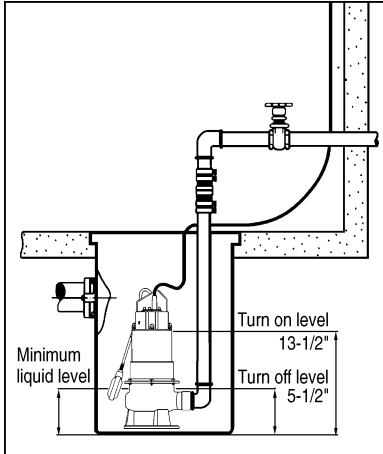

TROUBLESHOOTING

PUMP WON'T START

- Blown fuse or tripped circuit
- Low voltage line
- Defective motor
- Impeller clogged
- Not primed
- Check power supply.
- Check power supply.
- Overheated and burned out unit must be replaced.
- Check for proper particle size. Maximum 2" and 2% concentrate and raise from bottom of pit.
- Reposition pump in liquid with minimum 5-1/2" liquid.

PUMP CYCLES ON AND OFF

- Insufficient liquid
- Pump run dry
- Liquid temperature to high
- Reposition pump in pit or remove if liquid is too low.
- Keep liquid within pump limits. Remove if liquid is low.
- Keep liquid within pump limits.

PUMP OPERATES BUT DELIVERS LITTLE FLOW

- Impeller clogged
- Low voltage
- Worn seals
- Check liquid and particle size. Flush impeller area.
- Check power supply.
- Replace pump unit.

WARRANTY

This pump is warranted for one year from date of purchase.

Improper installation and use will void the warranty. Tampering with the power cord, impeller or seals will void the warranty.

2K SERIES PERFORMANCE RANGES

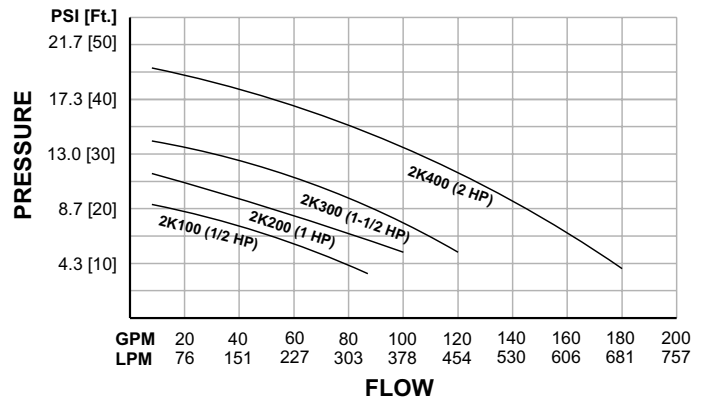

AUTOMATIC MODELS

Model	HP	Phase	Volts	Amps	Pump-Motor Dimensions (in.)			Wt. (lbs.)
					A	B	C	
2K100	1/2	1	115	8.30	21.63	9.0	3.88	36
2K102	1/2	1	208/230	4.40/4.40	19.13	9.0	3.88	36
2K200	1	1	115	*11.80	22.81	9.0	3.88	41
2K202	1	1	208/230	6.40/6.40	22.81	9.0	3.88	44
2K302	1-1/2	1	208/230	7.00/7.00	20.25	9.0	3.88	45

MANUAL MODELS

Model	HP	Phase	Volts	Amps	Pump-Motor Dimensions (in.)			Wt. (lbs.)
					A	B	C	
2K101	1/2	1	115	8.30	21.63	9.0	3.88	36
2K103	1/2	1	208/230	4.40/4.40	21.63	9.0	3.88	36
2K104	1/2	3	208/230	3.00/3.00	19.13	9.0	3.88	32
2K105	1/2	3	460	1.28	19.13	9.0	3.88	32
2K201	1	1	115	*11.80	22.81	9.0	3.88	41
2K203	1	1	208/230	6.40/6.40	20.25	9.0	3.88	41
2K204	1	3	208/230	4.20/4.20	19.13	9.0	3.88	36
2K205	1	3	460	1.99	19.13	9.0	3.88	36
2K303	1-1/2	1	208/230	7.00/7.00	20.25	9.0	3.88	47
2K304	1-1/2	3	208/230	4.80/4.80	20.25	9.0	3.88	42
2K305	1-1/2	3	460	2.34	20.25	9.0	3.88	42
2K403	2	1	208/230	*9.10/9.10	24.00	9.0	3.88	52
2K404	2	3	208/230	7.40/7.40	20.25	9.0	3.88	47
2K405	2	3	460	3.50	20.25	9.0	3.88	47

Only single phase has motor over-load and auto-reset. *14 Gauge wire.

DIMENSIONAL

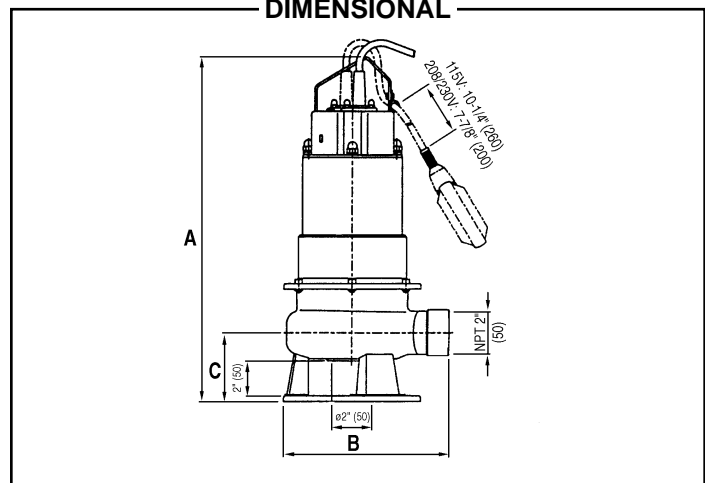

Products described hereon are covered by one or more of the following U.S. patents 3558244, 3652188, 3809508, 3920356, 3930756 and 5035580

World Headquarters

CAT PUMPS

1681 - 94th Lane N.E. Minneapolis, MN 55449-4324

Phone (763) 780-5440 — FAX (763) 780-2958

e-mail: techsupport@catpumps.com

www.catpumps.com

International Inquiries

FAX (763) 785-4329

e-mail: intlsales@catpumps.com



The Pumps with Nine Lives

CAT PUMPS (U.K.) LTD.

1 Fleet Business Park, Sandy Lane, Church Crookham, Fleet

Hampshire GU52 8BF, England

Phone Fleet 44 1252-622031 — Fax 44 1252-626655

e-mail: sales@catpumps.co.uk

N.V. CAT PUMPS INTERNATIONAL S.A.

Heiveldekens 6A, 2550 Kontich, Belgium

Phone 32-3-450.71.50 — Fax 32-3-450.71.51

e-mail: cpi@catpumps.be www.catpumps.be

CAT PUMPS DEUTSCHLAND GmbH

Buchwiese 2, D-65510 Idstein, Germany

Phone 49 6126-9303 0 — Fax 49 6126-9303 33

e-mail: catpumps@t-online.de www.catpumps.de