

Electric motor or gas engine must be purchased separately.

PUMP FEATURES

- Triplex plunger design provides a smooth liquid flow.
- Specially formulated Hi-Pressure Seals and concentrically ground ceramic plungers assure maximum seal life.
- Ultimate compact, direct-drive unit for maximum portability.
- Modular Regulating Unloader with built-in by-pass standard on all units to assure system pressure control and pump protection.
- Built-in chemical injector standard on all units offers cleaning flexibility.
- Stacked valve design for ease in servicing.
- Inlet, swivel, garden hose fitting with filter screen.

⚠ WARNING

All systems require both a primary pressure regulating device (i.e., regulator, unloader) and a secondary pressure safety relief device (i.e., pop-off valve, safety valve). Failure to install such relief devices could result in personal injury or damage to the pump or to system components. CAT PUMPS does not assume any liability or responsibility for the operation of a customer's high pressure system.

Direct-Drive Plunger Pumps

Electric Model **2DX20ES**
Gas Models **2DX27GS**
 2DX30GS

SPECIFICATIONS

	U.S. Measure	Metric Measure
MODEL 2DX20ES		
Flow	2.0 GPM	(7.6 L/M)
Max. Discharge Pressure	2000 PSI	(140 BAR)
RPM	3450 RPM	(3450 RPM)
Stroke	0.157"	(4.0 mm)
Shaft Diameter.....	.5/8"	(15.8 mm)
MODEL 2DX27GS		
Flow	2.7 GPM	(10.2 L/M)
Max. Discharge Pressure	2000 PSI	(140 BAR)
RPM	3450 RPM	(3450 RPM)
Stroke	0.220"	(5.6 mm)
Shaft Diameter.....	.3/4"	(19.0 mm)
MODEL 2DX30GS		
Flow	3.1 GPM	(11.7 L/M)
Max. Discharge Pressure	2000 PSI	(140 BAR)
RPM	3450 RPM	(3450 RPM)
Stroke	0.244"	(6.2 mm)
Shaft Diameter.....	.3/4"	(19.0 mm)

COMMON SPECIFICATIONS

Inlet Pressure Range	Flooded to 60 PSI	(Flooded to 4 Bar)
Bore	0.630"	(16 mm)
Max. Liquid Temperature	140° F	(60° C)
Crankcase Capacity.....	8.5 oz.	(0.25 L)
Inlet Ports (1)	3/4" GH	(3/4" GH)
Discharge Port (1)	3/8" NPTM	(3/8" NPTM)
Chemical Injection Barb	8/32" UNF	(8/32" UNF)
Weight	10.7 lbs.	(4.9 kg)
Dimensions	7.99 x 7.75 x 6.29"	(203 x 197 x 160 mm)

NOTE: Contact CAT PUMPS for available "MIST" models for specific flows from 0.5 to 3.0 GPM.

HORSEPOWER REQUIREMENTS

MODEL	FLOW		PRESSURE				RPM
			PSI 1000	PSI 1200	PSI 1500	PSI 2000	
	U.S. GPM	L/M	BAR 70	BAR 85	BAR 105	BAR 140	
2DX20ES	2.0	7.6	1.37	1.64	2.05	2.74	3450
2DX27GS	2.7	10.2	1.85	2.25	2.77	3.70	3450
2DX30GS	3.1	11.7	2.12	2.55	3.18	4.25	3450

DETERMINING THE PUMP R.P.M. $\frac{\text{Rated G.P.M.}}{\text{Rated R.P.M.}}$ = "Desired" G.P.M. / "Desired" R.P.M.

DETERMINING THE REQUIRED H.P. $\frac{\text{GPM} \times \text{PSI}}{1460}$ = Electric Brake / H. P. Required

DETERMINING MOTOR PULLEY SIZE $\frac{\text{Motor Pulley O.D.}}{\text{Pump R.P.M.}}$ = $\frac{\text{Pump Pulley O.D.}}{\text{Motor R.P.M.}}$

Note: Consult engine manufacturer when using gas or diesel engine.
Refer to pump Service Manual for repair procedure and additional technical information.

"Customer confidence is our greatest asset"

EXPLODED VIEW

August 2003

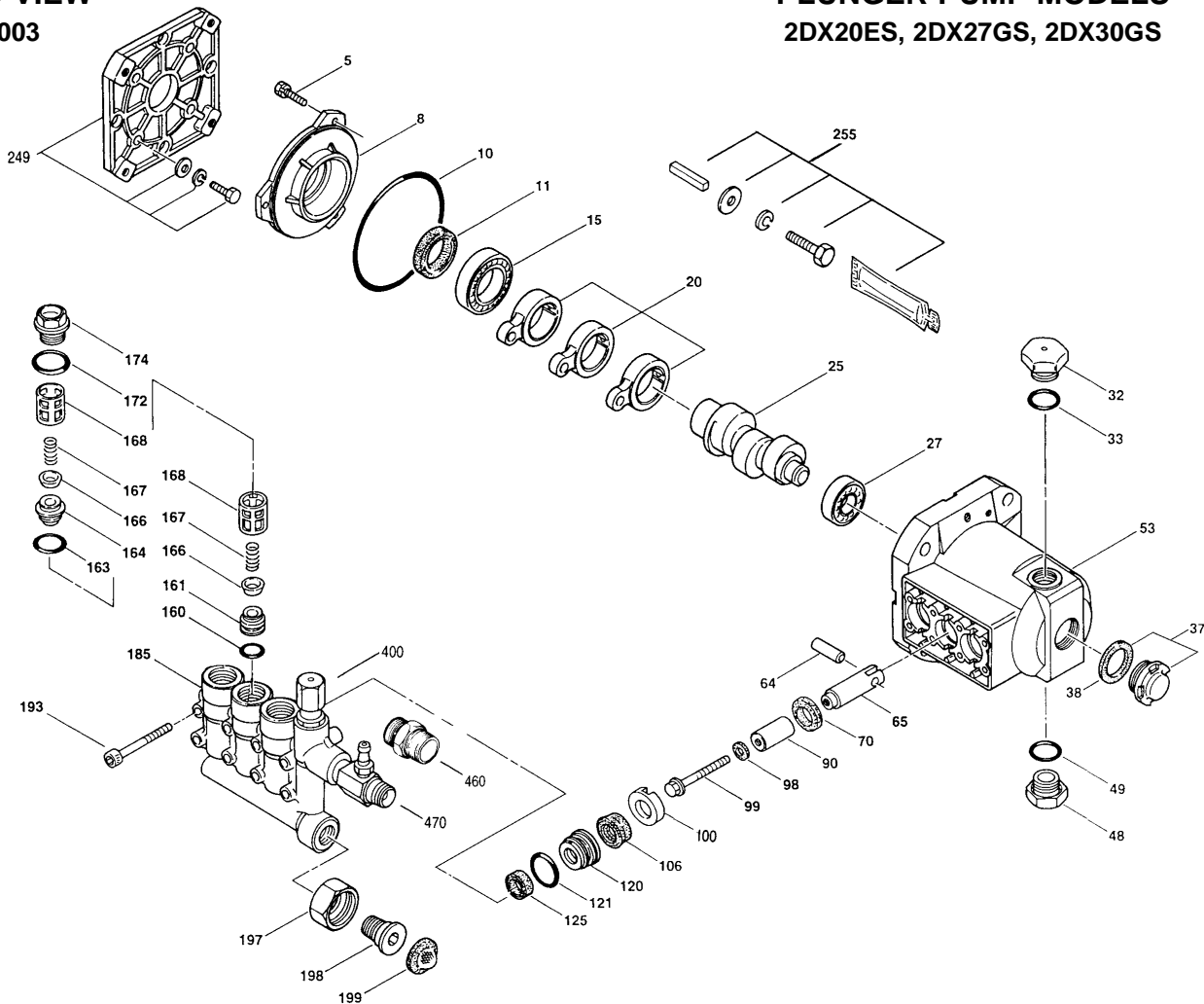

PLUNGER PUMP MODELS

2DX20ES, 2DX27GS, 2DX30GS

PARTS LIST

ITEM	P/N	MATL	DESCRIPTION	MODEL USED	QTY	ITEM	P/N	MATL	DESCRIPTION	MODEL USED	QTY
5	817003	STZP	Screw, HHC w/SW (M6x12)	All Models	3	160	13965	NBR	O-Ring, Inlet Valve Seat	All Models	3
8	46225	AL	Cover, Bearing	All Models	1	161	545177	S	Seat, Inlet	All Models	3
10	14041	NBR	O-Ring, Bearing Cover - 70D	All Models	1	163	19285	NBR	O-Ring, Seat	All Models	3
11	55337	NBR	Seal, Oil	All Models	1	164	545178	S	Seat, Discharge	All Models	3
15	14488	STL	Bearing, Ball	All Models	1	166	46764	S	Valve	All Models	6
20	46228	HS	Rod, Connecting	All Models	3	167	46865	S	Spring	All Models	6
25	545653	CM	Crankshaft, 1725 RPM, 5/8", 2.0 mm	05ELS	1	168	543988	PVDF	Retainer, Spring	All Models	6
	545144	CM	Crankshaft, 3450 RPM, 5/8", 3.0 mm	15ES	1	172	142807	NBR	O-Ring, Plug - 90D	All Models	3
	545765	CM	Crankshaft, 3450 RPM, 5/8", 4.0 mm	10ELS, 20ES	1	174	46759	BB	Plug, Valve (M22x1.5)	All Models	3
	545145	CM	Crankshaft, 3450 RPM, 5/8", 5.6 mm	27ES	1	185	542973	BB	Head, Manifold w/Modular Unloader Body	All Models	1
	544476	CM	Crankshaft, 3450 RPM, 3/4", 5.6 mm	27GS	1	193	542406	STZP	Screw, HSH (M6x60)	All Models	8
	543295	CM	Crankshaft, 3450 RPM, 3/4", 6.2 mm	30GS	1	197	46488	BB	Nut, Swivel (3/4" FGHIF)	20ES, 27GS, 30GS	1
27	13832	STL	Bearing, Ball	All Models	1	198	46487	BB	Fitting, (3/8" NPT)	20ES, 27GS, 30GS	1
32	45690	RTP	Cap, Oil Filler	All Models	1	199	46489	S	Screen, Inlet	20ES, 27GS, 30GS	1
33	14179	NBR	O-Ring, Oil Filler Cap - 70D	All Models	1	249	30520		Assy, Adapter Mount, Standard, GAS	27GS, 30GS	1
37	92241		Gauge, Bubble Oil w/Gasket	All Models	1	46271	AL	Flange			1
38	44428	NBR	Gasket, Flat Flex, Oil Gauge - 80D	All Models	1	44843	STZP	Screw, HH (5/16"-24UNFx20)			4
48	44842	NY	Plug, Drain	All Models	1	15845	STZP	Lockwasher (M8)			4
49	14179	NBR	O-Ring, Drain Plug - 70D	All Models	1	12489	STZP	Washer, Flat (M8)			4
53	542407	AL	Crankcase	All Models	1	255	30516	STZP	Assy, Bolt Mount, ELECTRIC/GAS	All Models	1
64	46229	CM	Pin, Crosshead	All Models	3	34100	STZP	Screw, HH (3/8"-16UNCx1-3/8")			4
65	542402	BBCP	Rod, Plunger	All Models	3	30980	STZP	Washer, Flat (3/8")			4
70	47215	NBR	Seal, Oil	All Models	3	30921	STZP	Lockwasher (3/8")			4
90	542403	CC	Plunger (M16x27)	All Models	3	6106	—	Lubricant, Antiseize			1
98	46730	NBR	Washer, Seal - 90D	All Models	3	34050	STL	Key (3/16x3/16x27 HD)			1
99	542405	S	Retainer, Plunger (M6x35)	All Models	3	300	33053	NBR	Kit, Seal (Incls: 98,106,121,125)	All Models	1
100	46233	NY	Retainer, Seal	All Models	3	310	33057	NBR	Kit, Valve (Incls: 160,161,163,164,166,167,168,172)	All Models	1
106	48222	NBR	Seal, LPS w/S-Spg	All Models	3	400	—		Unloader, Modular (See Indiv. Parts)	All Models	1
120	46436	BB	Case, Seal	All Models	3	460	107681	BB	Fitting, Discharge (3/8" NPTM)	.MIST Models	1
121	13976	NBR	O-Ring, Seal Case	All Models	3	470	—		Injector, Chemical (See Indiv. Parts)	20ES, 27GS, 30GS	1
125	46240	NBR	Seal, HPS w/S	All Models	3						

Italics are optional items. See Tech Bulletins 002, 024, 036, 043, 055, 074, 083 and 086 for additional information.

MATERIAL CODES (Not Part of Part Number): AL=Aluminum BB=Brass BBCP=Brass/Chrome Plated CC=Ceramic CM=Chrome-moly HS=High Strength NBR=Medium Nitrile (Buna-N) NY=Nylon PVDF=Fluoroplastic (High Strength) RTP=Reinforced Composite S=304SS STL=Steel STZP=Steel/Zinc Plated

NOTE: Discard Key which may come standard with most motors and engines and **use only the key included in this kit.**

Center raised pilot guide on the **Adapter Plate** assures proper alignment of pump and engine. Before mounting pump onto engine inspect engine for **recessed seal and bearing guide** to permit adapter to completely seat into recess and four bosses to be flush with engine face.

MODULAR UNLOADER

SPECIFICATIONS

	U.S. Measure	Metric Measure
GPM	3.1 GPM	(11.7 L/M)
PSI Range	100-2000 PSI	(7-140 BAR)
Discharge Port	M18x1.0	(M18x1.0)

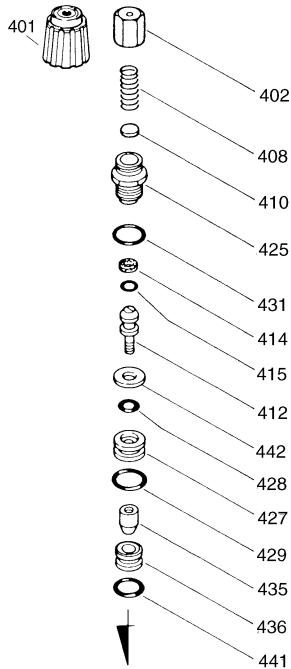

ITEM	PN	MATL	DESCRIPTION	QTY.
401	32088	NY	Handle, Adjustable	1
402	46570	BB	Cap, Adjusting	1
408	33394	STZP	Spring, Coil (2000 PSI)	1
410	45862	BB	Retainer, Spring	1
412	46251	BB	Stem, Piston	1
—	545869	BB	Assy, Piston	1
414	28338	PTFE	Back-up-Ring, Piston Stem	1
415	22056	NBR	O-Ring, Piston Stem	1
425	46248	BB	Retainer, Piston	1
427	46249	BB	Retainer, Valve	1
428	17399	NBR	O-Ring, Valve Retainer (Inner) - 80D	1
429	13966	NBR	O-Ring, Valve Retainer (Outer)	1
431	13969	NBR	O-Ring, Piston Retainer - 70D	1
435	46733	S	Valve	1
436	46253	S	Seat	1
441	13963	NBR	O-Ring, Seat	1
442	46250	S	Washer	1
468	33099	NBR	Kit, O-Ring (Incls: 414,415,428,429,431,441)	1
—	31088	NBR	Kit, Repair (Incls: 412,431,436,441)	1

Italics are optional items.

NOTE: If check valve is removed, unloader becomes a regulator.

MATERIAL CODES (Not Part of Part Number):

BB=Brass NBR=Medium Nitrile (Buna-N) NY=Nylon PTFE=Pure Teflon®
S=304SS STZP=Steel/Zinc Plated

The modular Regulating Unloader with built-in by-pass is part of the discharge manifold and is very easily serviced from the top. Remove Hex Adjusting Cap and lift parts from body.

If unit is INFREQUENTLY USED OR PERIODICALLY STORED, seals may become dry. System should be PURGED OF AIR BEFORE OPERATION (system liquid must flow through the pump without discharge restriction) to assure full system pressure is reached.

SERVICE: The unloader should be serviced on the same schedule as your pump. Replacing the O-rings is generally all that is required. Lubricate the O-rings for ease of installation and replace all O-rings and Back-up-Rings included in the kit. Examine the seating surfaces of the seat and valve assembly and replace as needed. **NOTE: The seat will be damaged during removal.** See Service Manual for additional information. Check for worn pressure spring and replace as needed. Examine check valve with O-ring and replace as needed. Thread the adjusting cap onto the unloader and reset system pressure.

FIXED CHEMICAL INJECTOR

SPECIFICATIONS

	U.S. Measure	Metric Measure
Model 7231		
GPM	2.0 GPM	(7.6 L/M)
Nozzle Orifice	1.8 mm	(1.8 mm)

Model 7232

GPM	3.0 GPM	(11.4 L/M)
Nozzle Orifice	2.1 mm	(2.1 mm)

Common Specifications

Hose Barb	1/4"	(1/4")
Tapped Barb	8/32" UNF	(8/32" UNF)
Inlet Port	M18x1.0	(M18x1.0)
Discharge Port	3/8" NPTM	(3/8" NPTM)
Weight	5.3 oz.	(0.15 kg)
Dimensions	2 x 1 x 1.75"	(52 x 25 x 45 mm)

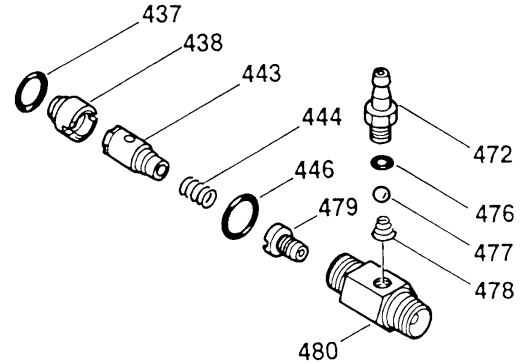

ITEM	PN	MATL	DESCRIPTION	QTY.
437	13963	NBR	O-Ring, Seat	1
438	46254	NY	Seat	1
443	541060	BB	Valve, Check w/O-Ring	1
444	45924	S	Spring	1
446	13969	NBR	O-Ring, Adapter - 70D	1
472	46630	BB	Barb, Tapped	1
476	14187	NBR	O-Ring, Injector Valve	1
477	46259	S	Ball, Seat	1
478	46260	S	Spring, Injector Valve	1
479	46531	BB	Orifice (2.1 mm)	1
	46257	BB	Orifice (1.8 mm)	1
480	—	BB	Body	1

MATERIAL CODES (Not Part of Part Number):

BB=Brass NBR=Medium Nitrile (Buna-N) NY=Nylon S=304SS

CHEMICAL INJECTOR PERFORMANCE CHART

Optional Special Ported Chemical Injector for Unloader Mounting

Standard Pump Model	Injector Orifice Size	Injector Model	Lo-Pressure Nozzle Rating (Max. Downstream) (Press for Injector)	Max. Chem. Draw (0 PSI) (Downstream)	Hi-Press Nozzle "Deduction" (Press drop across Inj.)
2DX20ES	1.8 mm	7231	100 PSI	52 oz/min	100 PSI
2DX27GS, 2DX30GS	2.1 mm	7232	150 PSI	50 oz/min	125 PSI

Optimum performance of chemical injector occurs with a 35 ft. high pressure hose and a minimum 3/8" I.D. The type of hose, extended lengths, reduced I.D. and fittings may create back pressures in excess of the low pressure nozzle rating and prevent the injector from drawing chemical. See Hose Friction Loss Chart in Service Manual. **Deduct hose friction loss from above low PSI Nozzle. Consult CAT PUMPS for assistance with other options.**

CAUTION: Deduct the pressure drop shown in the performance chart from your desired system pressure to arrive at the maximum high pressure nozzle rating. This is essential to avoid over-pressurizing the pump.

NOTE: Fixed Chemical Injector not used with .MIST models.

The Chemical Injector is mounted directly to the discharge of the unloader. **Chemical draw occurs under low pressure.** Select the *Change Over Nozzle* (32149), *Adjustable Nozzle* (32151), or *Vari-Nozzle* (7930-7980) to permit the adjustment from low to high pressure

For correct nozzle selection, **read system pressure at the pump. DO NOT READ SYSTEM PRESSURE AT THE HIGH PRESSURE GUN.** Incorrect pressure reading may result in: pump operation at excessive pressures, inconsistent chemical draw or possible damage to the pump or unloader.

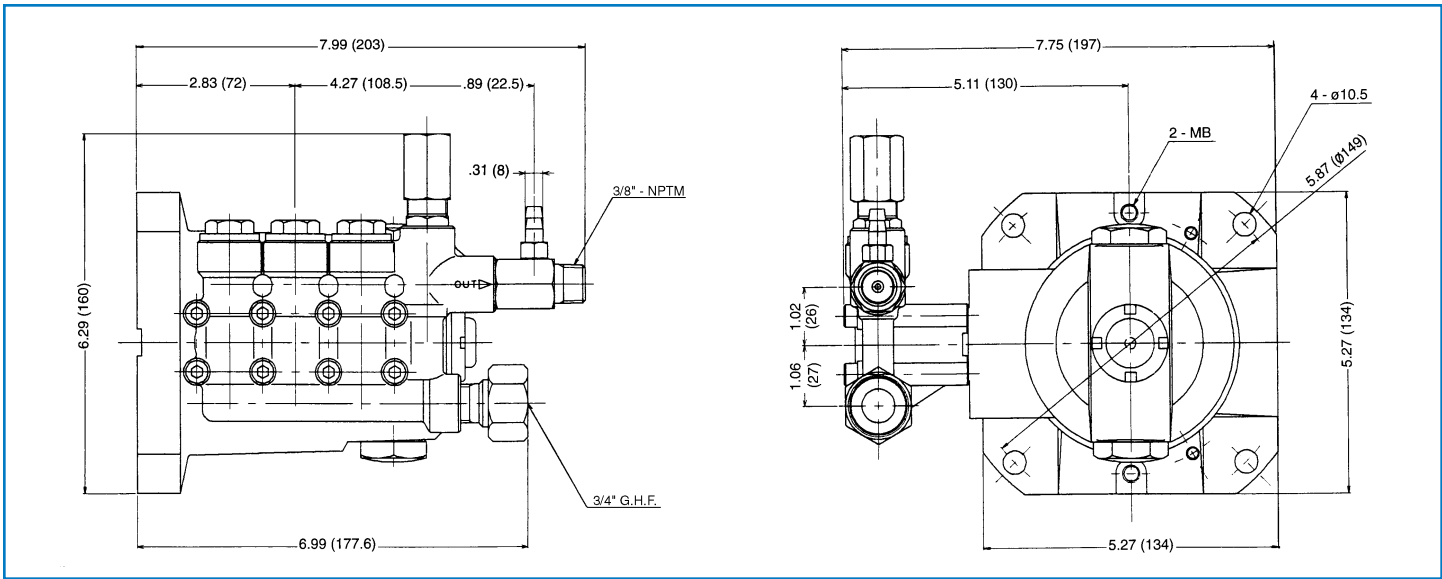

Models 2DX20ES, 2DX27GS, 2DX30GS

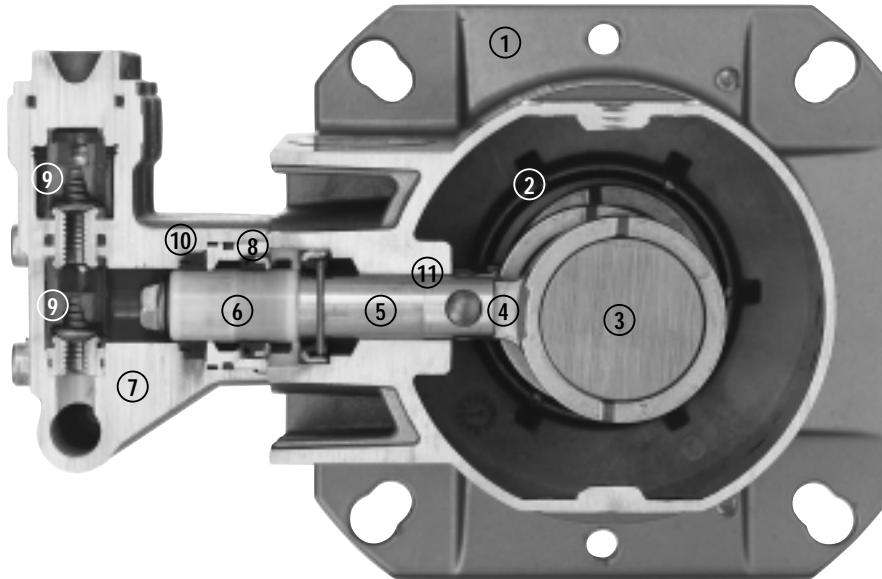

- | | | |
|--|--|---|
| <p>1 Die cast flange-style aluminum crankcase means high strength, lightweight, and excellent tolerance control.</p> <p>2 Heavy-duty dual crankshaft bearings provide extended drive-end life.</p> <p>3 Chrome-moly crankshaft provides unmatched strength and surface hardness for long life.</p> <p>4 High strength connecting rods assure durability and bearing quality.</p> | <p>5 Strong chrome plated brass plunger rods with chrom-moly crosshead pins.</p> <p>6 Special, concentric, high-density, polished solid ceramic plungers are abrasion resistant and offer enhanced seal life.</p> <p>7 High tensile strength, forged brass manifold head with built-in modular unloader and eight mounting screws for exceptional strength.</p> <p>8 100% wet seal design adds to service life by allowing pumped liquids to cool and lubricate on both sides.</p> | <p>9 Stainless steel valves, seats and springs provide corrosion-resistance, positive seating and long life.</p> <p>10 Unique design and specially formulated Hi-Pressure Seals offer unmatched performance and seal life.</p> <p>11 Crossheads are 360° supported for uncompromising alignment.</p> |
|--|--|---|

Products described hereon are covered by one or more of the following U.S. patents 3558244, 3652188, 3809508, 3920356, 3930756 and 5035580

World Headquarters
CAT PUMPS
 1681 - 94th Lane N.E. Minneapolis, MN 55449-4324
 Phone (763) 780-5440 — FAX (763) 780-2958
 e-mail: techsupport@catpumps.com
 www.catpumps.com

International Inquiries
 FAX (763) 785-4329
 e-mail: intlsales@catpumps.com



CAT PUMPS (U.K.) LTD.
 1 Fleet Business Park, Sandy Lane, Church Crookham, Fleet
 Hampshire GU52 8BF, England
 Phone Fleet 44 1252-622031 — Fax 44 1252-626655
 e-mail: sales@catpumps.co.uk

N.V. CAT PUMPS INTERNATIONAL S.A.
 Heiveldekens 6A, 2550 Kontich, Belgium
 Phone 32-3-450.71.50 — Fax 32-3-450.71.51
 e-mail: cpi@catpumps.be www.catpumps.be

CAT PUMPS DEUTSCHLAND GmbH
 Buchwiese 2, D-65510 Idstein, Germany
 Phone 49 6126-9303 0 — Fax 49 6126-9303 33
 e-mail: catpumps@t-online.de www.catpumps.de