



# 28 Frame Block-Style Stainless Steel Plunger Pump

Models **2831**  
**2831K**

### FEATURES

#### Superior Design

- Triplex plunger design gives smoother fluid flow.
- Inlet and discharge valve assemblies interchange for easier maintenance.
- Oil bath crankcase assures optimum drive-end lubrication.
- Close tolerance concentricity of the ceramic plunger maximizes seal life.
- **Standard Models:** Lo-Pressure Seals and V-Packings are completely lubricated and cooled by the fluid being pumped.

**Flushed Models:** Special ported inlet manifold permits fluid to cool or flush between V-Packings and Lo-Pressure Seals providing protection against high temperatures or contaminating pumped fluids.

#### Quality Materials

- All 316 stainless steel valves are heat treated and seats are roller burnished for a positive seal and extended valve life.
- Block style 316 Stainless Steel manifolds for strength and corrosion resistance.
- Special concentric, high density, polished, graphite impregnated, soid ceramic plungers are abrasion resistant and result in extended seal life.
- Specially formulated, CAT PUMP exclusive, Hi-Pressure Seals offer unmatched performance and seal life.
- Die cast aluminum crankcase provides high strength, minimum weight and precision tolerance control.
- Optional Cast Iron crankcase for hazardous environments.
- Chrome-moly crankshaft gives unmatched strength and surface hardness.
- Oversized crankshaft bearings mean longer bearing life.

#### Easy Maintenance

- Wet-end is easily serviced without entering crankcase, requiring less time and effort.
- Preset packings mean no packing gland adjustment is necessary, reducing maintenance costs.

### SPECIFICATIONS

	U.S. Measure	Metric Measure
Volume .....	.21 GPM	(80 L/M)
Discharge Pressure .....	100 to 1200 PSI	(7 to 85 BAR)
Maximum Inlet Pressure.....	Flooded to 70 PSI	(Flooded to 4.9 BAR)
RPM .....	860 RPM	(860 RPM)
Bore.....	1.260"	(32 mm)
Stroke.....	1.516"	(38.5 mm)
Crankcase Capacity .....	84 oz.	(2.5 L)
Maximum Fluid Temperature .....	160°F	(71°C)
Inlet Ports (2) .....	1-1/4" NPT	(1-1/4" NPT)
Discharge Ports (2) .....	3/4" NPT	(3/4" NPT)
Pulley Mounting .....	Either Side	(Either Side)
Shaft Diameter .....	1.181"	(30 mm)
Weight.....	.82 lbs.	(37.1 kg)
Dimensions .....	18.98" x 15.04" x 10.08"	(482 x 382 x 256 mm)

### HORSEPOWER REQUIREMENTS

FLOW		PRESSURE			RPM	DRIVE
U.S. GPM	L/M	PSI 800	PSI 1000	PSI 1200		
		BAR 55	BAR 70	BAR 85		Consult Pulley Mfr. for Pump and Motor Pulley Sizes
21	80	11.5	14.4	17.3	860	
20	26	11.0	13.7	16.5	820	
18	68	9.9	12.4	14.8	737	
15	57	8.3	10.3	12.4	615	

See complete Drive Packages [Incls: Pulleys, Belts, Hubs, Key] Tech Bulletin 03.

**DETERMINING THE PUMP R.P.M.**  $\frac{\text{Rated G.P.M.}}{\text{Rated R.P.M.}} = \frac{\text{"Desired" G.P.M.}}{\text{"Desired" R.P.M.}}$

**DETERMINING THE REQUIRED H.P.**  $\frac{\text{GPM x PSI}}{1460} = \text{Electric Brake H. P. Required}$

**DETERMINING MOTOR PULLEY SIZE**  $\frac{\text{Motor Pulley O.D.}}{\text{Pump R.P.M.}} = \frac{\text{Pump Pulley O.D.}}{\text{Motor R.P.M.}}$

Note: Consult engine manufacturer when using gas or diesel engine. Refer to pump Service Manual for important Inlet Condition Check-List, Start-up Procedure, Tech Bulletins and Pump Maintenance information.

# PARTS LIST

ITEM	PART NUMBER		DESCRIPTION		QTY
	2831	MATL	2831K	MATL	
● 2	50146	STL	50146	STL	Key (M7x7x40) 1 ●
5	89277	SS	89277	SS	Screw (M8x25) 8
6	15846	S	15846	S	Washer, Spring (M8) 8
7	13534	SS	13534	SS	Washer (M8) 8
8	27773	AL	27773	AL	Cover, Bearing 2
10	27772	NBR	27772	NBR	O-Ring, Bearing Cover 2
11	27771	NBR	27771	NBR	Seal, Crankshaft, Oil 2
15	26512	STL	26512	STL	Bearing 2
20	27776	ZZ	27776	ZZ	Rod Assy, Connecting 3
25	27770	FCM	27770	FCM	Crankshaft 1
31	828710		828710		Protector, Oil Cap 1
32	43211		43211		Cap, Oil Filler 1
33	14177	NBR	14177	NBR	O-Ring, Oil Filler Cap 1
38	11338	NBR	11338	NBR	O-Ring, Dipstick 1
39	27769	RTP	27769	RTP	Dipstick 1
40	89277	SS	89277	SS	Screw (M8x25) 8
41	15846	S	15846	S	Washer, Spring, (M8) 8
42	13534	SS	13534	SS	Washer (M8) 8
48	25625	STCP	25625	STCP	Plug, Drain 1
49	23170	NBR	23170	NBR	O-Ring, Drain Plug 1
50	27768	AL	27768	AL	Cover, Crankcase 1
51	27767	NBR	27767	NBR	O-Ring, Crankcase Cover 1
● 53	27762	AL	27762	AL	Crankcase w/Guide Pins 1 ●
55	27488	S	27488	S	Pin, Guide 2
56	27790	POP	27790	POP	Pan, Oil 1
59	89618	S	89618	S	Screw (M6x16) 2
64	27784	S	27784	S	Pin, Rist, Plunger Rod 3
65	45828	SSZZ	45828	SSZZ	Rod, Plunger 3
70	27785	NBR	27785	NBR	Seal, Crankcase, Oil 3
75	110669	S	110669	S	Slinger, Barrier 3
88	110670	S	110670	S	Washer, Keyhole 3
90	45749	CC	45749	CC	Plunger 3
95	89835	SS	89835	SS	Stud, Retainer, (M7) 3
96	20184	PTFE	20184	PTFE	Back-up-Ring, Plunger Retainer 3
97	14190	NBR	14190	NBR	O-Ring, Plunger Retainer 3
	◆ 48239	EPDM	◆ 48239	EPDM	O-Ring, Plunger Retainer 3
98	44069	SS	44069	SS	Gasket, Plunger Retainer 3
99	44068	SS	44068	SS	Retainer, Plunger 3
100	110672	NY	110672	NY	Retainer, Seal 3
106	44098	NBR	44098	NBR	Seal, LPS w/SS-Spg 3
	◆ 48244	EPDM	◆ 48244	EPDM	Seal, LPS w/SS-Spg 1
● 110	701661	SS	—	—	Manifold, Inlet, Block-Style 1 ●
●	—	—	701719	SS	Manifold, Inlet, Block-Style, Flushed 1 ●
111	701104	SS	701104	SS	Plug, Inlet Manifold, (1-1/4" NPT) 1
117	701693	S	701693	S	Screw (M12x80) 4
118	701077	SS	701077	SS	Plug, (1/4" NPT), Flush Port 3
125	45832	NBR	45832	NBR	Seal, HPS w/SS 3
	48220	PTFE	48220	PTFE	Seal, HPS w/SS 3
143	14200	NBR	14200	NBR	O-Ring, Valve Adapter, Small - 70 6
	◆ 701654	EPDM	◆ 701654	EPDM	O-Ring, Valve Adapter, Small 6
144	28243	PTFE	28243	PTFE	Back-up-Ring, Valve Adapter 6
150	701675	SS	701675	SS	Adapter, Valve 3
154	11379	NBR	11379	NBR	O-Ring, Valve Adapter, Large 6
	◆ 701784	EPDM	◆ 701784	EPDM	O-Ring, Valve Adapter, Large 6
155	14520	NBR	14520	NBR	O-Ring, Seal Spacer 6
	◆ 28240	EPDM	◆ 28240	EPDM	O-Ring, Seal Spacer 6
157	701692	SS	701692	SS	Spacer, Seal 3
162	21985	PTFE	21985	PTFE	Back-up-Ring, Seat 6
163	26089	NBR	26089	NBR	O-Ring, Seat - 80 6
	◆ 701655	EPDM	◆ 701655	EPDM	O-Ring, Seat 6
164	44080	SS	44080	SS	Seat 6
166	44081	SS	44081	SS	Valve 6
167	44082	SS	44082	SS	Spring 6
168	44735	PVDF	44735	PVDF	Retainer, Spring 6
170	44794	SS	44794	SS	Washer, Spring Retainer 6
172	700008	NBR	700008	NBR	O-Ring, Valve Plug 3
	◆ 701782	EPDM	◆ 701782	EPDM	O-Ring, Valve Plug 3
174	701694	SS	701694	SS	Plug, Valve 3
● 185	701662	SS	701662	SS	Manifold, Discharge, Block-Style 1 ●
188	89628	SS	89628	SS	Screw (M12x65) 16

# EXPLODED VIEW

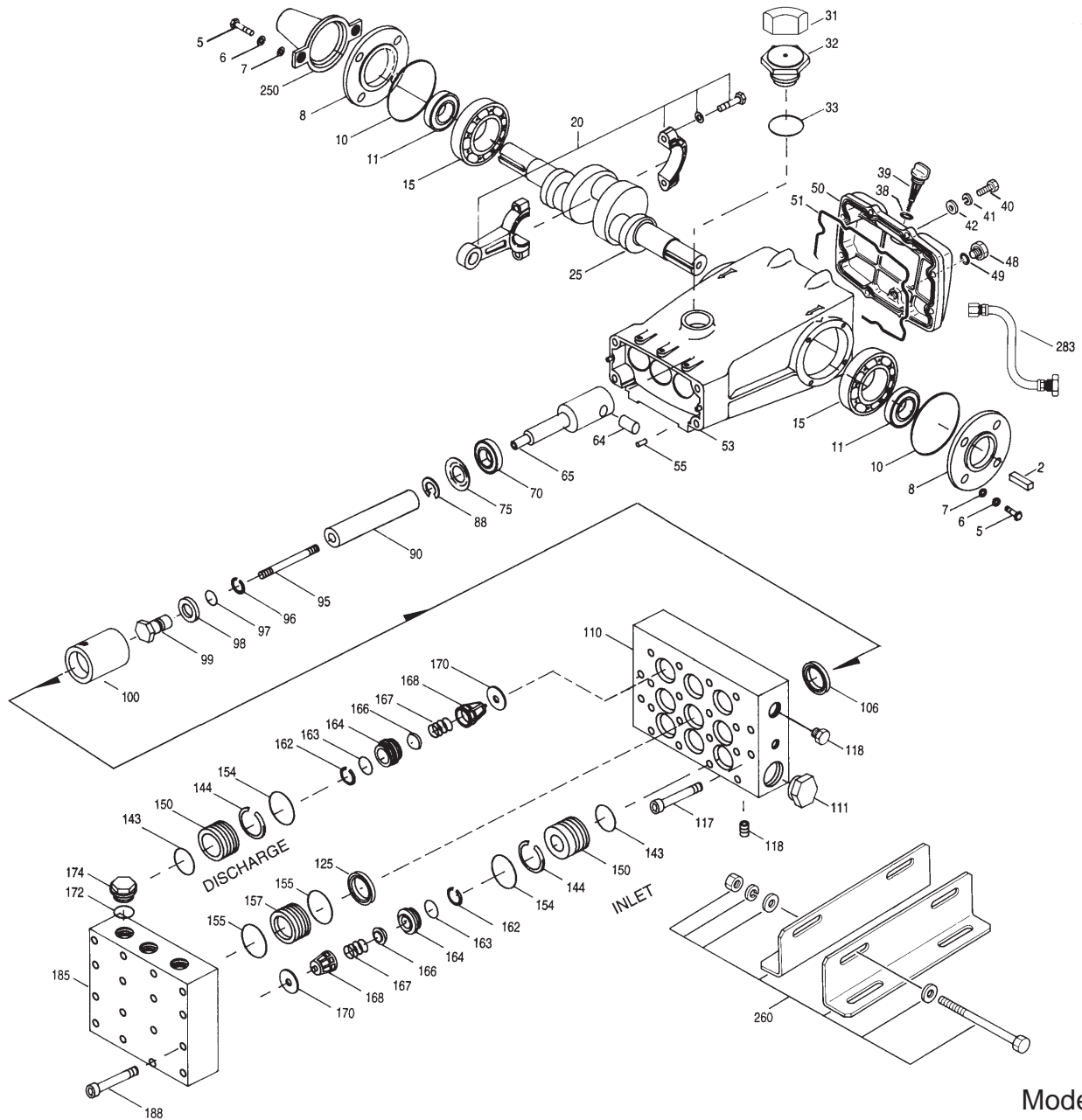

Models  
2831, 2831K  
June 1998

250	26516	STCP	26516	STCP	Protector, Shaft	1
260	30614	STZP	30614	STZP	Rail Assy, Angle (Incls: 27808, 30902, 30930, 30908, 30911)	1
● 269	30206	F	30206	F	9.75" Pulley [See complete Drive Packages, Tech Bulletin 03]	1 ●
● 270	30207	STL	30207	STL	Hub [See complete Drive Packages, Tech Bulletin 03]	1 ●
● 283	34334		34334		Kit, Oil Drain	1 ●
290	6108		6108		Gasket, Liquid	1
● 299	<b>901402</b>	<b>SSL</b>	—	—	Head, Complete, Block-Style	1 ●
●	—	—	<b>901403</b>	<b>SSL</b>	Head, Complete, Block-Style, Flushed	1 ●
306	701731	NBR	701731	NBR	Kit, Seal (Incls: 96,97,106,125,143,144,154,155)	1
	33604	EPDM	33604	EPDM	Kit, Seal (Incls: 96,97,106,125,143,144,154,155)	1
310	701732	NBR	701732	NBR	Kit, Valve (Incls: 143,144,154,155,162,163,164,166,167,168,170,172)	2
	◆ 701796	EDPM	◆ 701796	EDPM	Kit, Valve (Incls: 143,144,154,155,162,163,164,166,167,168,170,172)	2
● 370	—	—	990663	—	Assembly, Flushing	1 ●
● 390	—	—	—	—	C.A.T. (Captive Acceleration Tube)	1 ●
● 391	—	—	—	—	Adapter (2 per C.A.T.) (See Data Sheet for complete selection)	2 ●

● Industrial discount. **Bold print part numbers are unique to a particular pump model.** *Italics are optional items.* ◆ Silicone oil/grease required.

See Tech Bulletins 03, 24, 36, 43, 53, 74, and 77 for additional information.

**MATERIAL CODES (Not Part of Part Number):** AL=Aluminum BB=Brass BBCP=Brass/Chrome Plated CC=Ceramic  
EPDM=Ethylene Propylene Diene Monomer FCM=Forged Chrome-moly FPM=Fluorocarbon (Viton®) NBR=Medium Nitrile (Buna-N) NY=Nylon  
POP=Polypropylene PTFE=Polytetrafluoroethylene (Teflon®) PVDF=Fluoroplastic (High Strength) RTP=Reinforced Composite S=304SS  
SS=316SS SSZZ=316SS/Zamak STCP=Steel/Chrome Plated STL=Steel STZP=Steel/Zinc Plated ZZ=Zamak

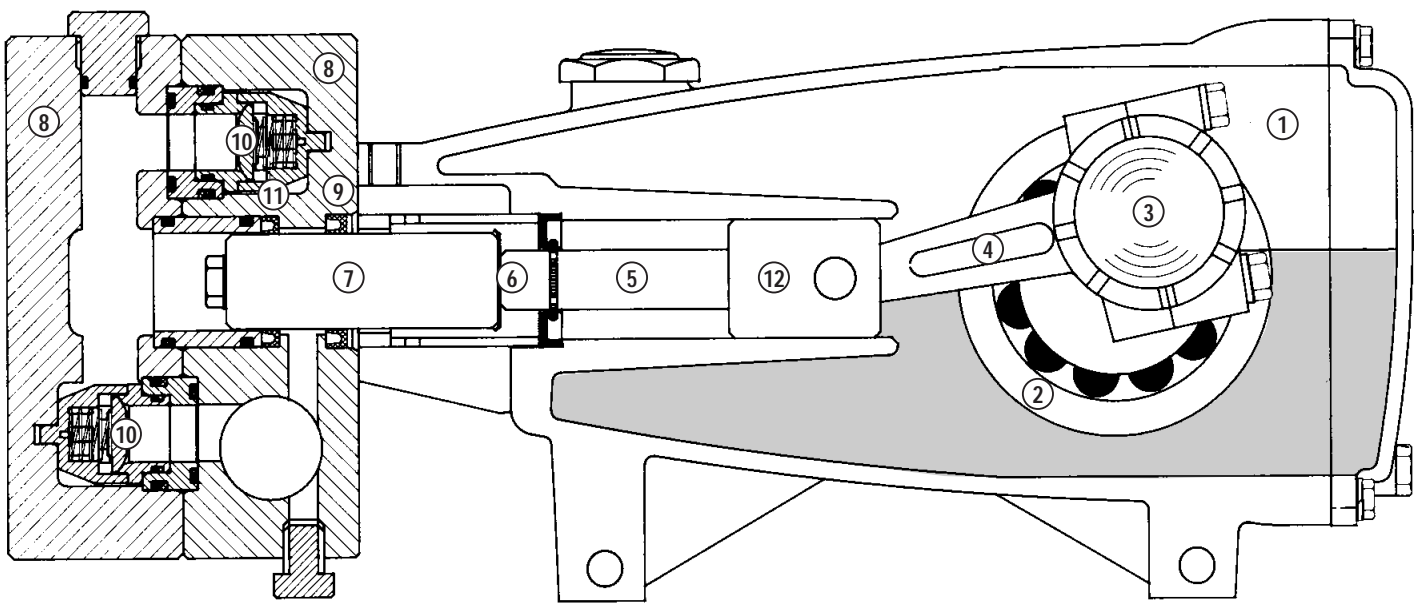
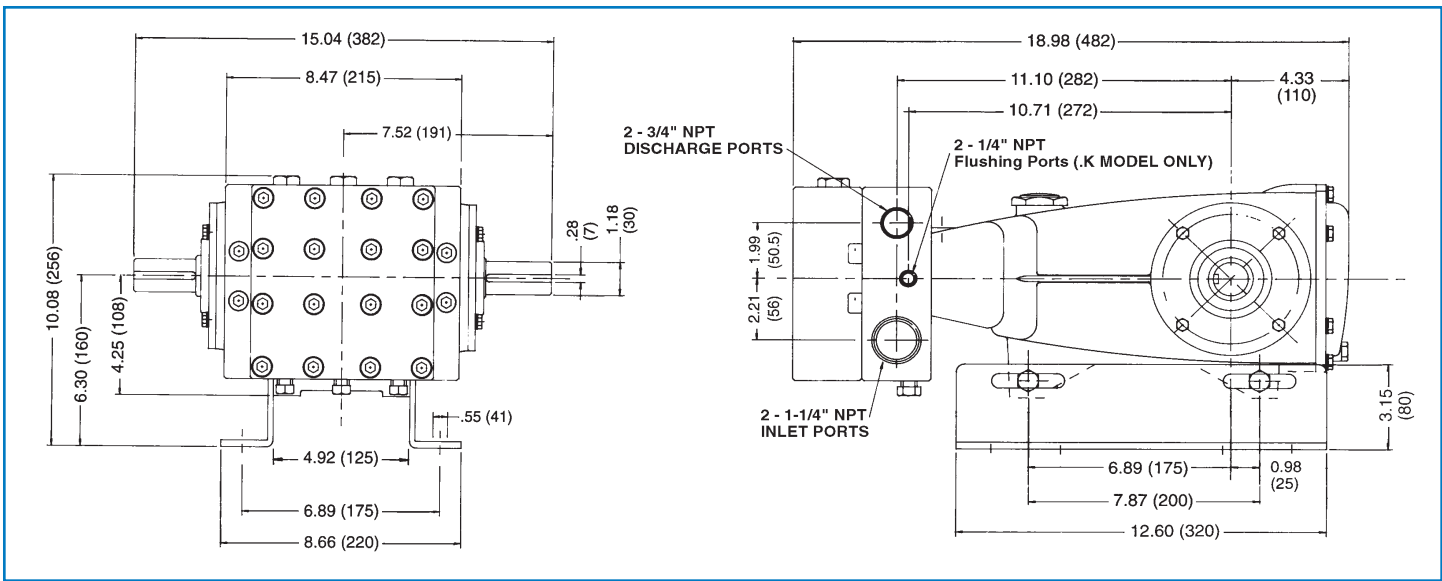

- |  |  |  |
|--|--|--|
| <p>1 Die cast aluminum <b>crankcase</b> means high strength, lightweight, and excellent tolerance control.</p> <p>2 Oversized crankshaft <b>bearings</b> provide extended bearing life and pump performance.</p> <p>3 Chrome-moly <b>crankshaft</b> provides unmatched strength and surface hardness for long life.</p> <p>4 Matched oversized <b>connecting rods</b> are made of Zamack, a material noted for strength and superior bearing quality.</p> <p>5 The <b>plunger rods</b> are high tensile strength 316 stainless steel with Zamack crossheads.</p> | <p>6 The stainless steel <b>slinger</b> provides back-up protection for the crankcase seal, keeping pumped fluids out of the crankcase.</p> <p>7 Special concentric, high density, polished, graphite impregnated, solid ceramic <b>plungers</b> are abrasion resistant and result in extended seal life.</p> <p>8 <b>Manifolds</b> are 316 stainless steel block-style for long-term, continuous-duty and corrosion resistance.</p> <p>9 <b>Standard Models:</b> Lo-Pressure Seals and V-Packings are completely lubricated and cooled by the fluid being pumped.</p> | <p>9 <b>Flushed Models:</b> Special ported inlet manifold permits fluid to cool or flush between V-Packings and Lo-Pressure Seals providing protection against high temperatures or contaminating pumped fluids.</p> <p>10 316 stainless steel <b>valves, seats and springs</b> provide corrosion-resistance, positive seating and long life.</p> <p>11 Specially formulated, CAT PUMP exclusive, <b>Hi-Pressure Seals</b> offer unmatched performance and seal life.</p> <p>12 <b>Crossheads</b> are 360° supported for uncompromising alignment.</p> |
|--|--|--|

Products described hereon are covered by one or more of the following U.S. patents 3558244, 3652188, 3809508, 3920356, 3930756 and 5035580

June 1998 3840

### World Headquarters

CAT PUMPS

1681 - 94th Lane N.E. Minneapolis, MN 55449-4324

Phone (612) 780-5440 — FAX (612) 780-2958

e-mail: sales@catpumps.com

www.catpumps.com

### International Inquiries

FAX (612) 785-4443

e-mail: intlsales@catpumps.com



The Pump with "Nine Lives"

### CAT PUMPS (U.K.) LTD.

1 Fleet Business Park, Sandy Lane, Church Crookham, Fleet

Hampshire GU13 0BF, England

Phone Fleet 44 1252-622031 — Fax 44 1252-626655

### N.V. CAT PUMPS INTERNATIONAL S.A.

Heiveldekens 6A, 2550 Kontich, Belgium

Phone 32-3-450.71.50 — Fax 32-3-450.71.51

e-mail: cpi@catpumps.be

### CAT PUMPS DEUTSCHLAND GmbH

Buchwiese 2, D-65510 Idstein, Germany

Phone 49 6126-93030 — Fax 49 6126-930333

e-mail: catpumps@t-online.de