

FEATURES

Superior Design

- Triplex plunger design gives smoother fluid flow.
- Hi-Pressure Seals are completely lubricated and cooled by the fluid being pumped.
- Inlet and discharge valve assemblies interchange for easier maintenance.
- Lubricated Lo-Pressure Seals provides double protection against external leakage.
- Oil bath crankcase assures optimum lubrication.
- Close tolerance concentricity of the ceramic plunger maximizes seal life.
- Optional Belt Drive, Motorized or Gearbox versions offer system flexibility.

Quality Materials

- All stainless steel valves are heat treated and seats are roller burnished for a positive seal and extended valve life.
- Stainless Steel and Nickel Aluminum Bronze manifolds are strong and corrosion resistant.
- Special concentric, high density, polished, graphite impregnated, solid ceramic plungers are abrasion resistant and result in extended seal life.
- Specially formulated, CAT PUMP exclusive, Hi-Pressure Seals offer unmatched performance and seal life.
- Die cast aluminum crankcase provides high strength, minimum weight and precision tolerance control.
- Chrome-moly crankshaft gives unmatched strength and surface hardness.
- Oversized crankshaft bearings with greater capacity mean longer bearing life.

Easy Maintenance

- Wet-end is easily serviced without entering crankcase, requiring less time and effort.
- Preset packings mean no packing gland adjustment is necessary, reducing maintenance costs.

DETERMINING THE PUMP R.P.M. $\frac{\text{Rated G.P.M.}}{\text{Rated R.P.M.}} = \frac{\text{"Desired" G.P.M.}}{\text{"Desired" R.P.M.}}$

DETERMINING THE REQUIRED H.P. $\frac{\text{GPM} \times \text{PSI}}{1460} = \text{Electric Brake H. P. Required}$

DETERMINING MOTOR PULLEY SIZE $\frac{\text{Motor Pulley O.D.}}{\text{Pump R.P.M.}} = \frac{\text{Pump Pulley O.D.}}{\text{Motor R.P.M.}}$

Note: Consult engine manufacturer when using gas or diesel engine. Refer to pump Service Manual for important Inlet Condition Check-List, Start-up Procedure, Tech Bulletins and Pump Maintenance information.

3 Frame Plunger Pump

Stainless Steel Models

231, 241, 271

Nickel Aluminum Bronze Models

237, 247, 277

SPECIFICATIONS

	U.S. Measure	Metric Measure
MODELS 231 AND 237		
Volume	2.3 GPM	(9 L/M)
Discharge Pressure	100 to 1500 PSI	(7 to 105 BAR)
RPM	1725 RPM	(1725 RPM)
Stroke	0.276"	(7 mm)

MODELS 241 AND 247

Volume	3.6 GPM	(13 L/M)
Discharge Pressure	100 to 1200 PSI	(7 to 85 BAR)
RPM	1725 RPM	(1725 RPM)
Stroke	0.433"	(11 mm)

MODELS 271 AND 277

Volume	3.5 GPM	(13 L/M)
Discharge Pressure	100 to 1500 PSI	(7 to 105 BAR)
RPM	1509 RPM	(1509 RPM)
Stroke	0.512"	(13 mm)

COMMON SPECIFICATIONS

Bore.....	0.709"	(18 mm)
Max. Inlet Pressure.....	Flooded to 60 PSI	(Flooded to 4 BAR)
Crankcase Capacity	10 oz.	(3 L)
Maximum Fluid Temperature.....	160°F	(71°C)
Inlet Ports (2)	1/2" NPT	(1/2" NPT)
Discharge Ports (2)	3/8" NPT	(3/8" NPT)
Pulley Mounting	Either Side	(Either Side)
Shaft Diameter	0.650"	(16.5 mm)
Weight.....	14.4 lbs.	(6.5 kg)
Dimensions.....	10.24" x 8.79" x 5.35"	(260 x 223 x 136 mm)

HORSEPOWER REQUIREMENTS

MODEL	FLOW		PRESSURE			MOTOR PULLEY SIZE	
			PSI 1000	PSI 1200	PSI 1500	Using 1725 RPM Motor & Std. 5.0" Pump Pulley O.D.	
	U.S. GPM	L/M	BAR 70	BAR 85	BAR 105	RPM	Pulley O.D.
271, 277	4.2	15	2.8	N/A	N/A	1725	4.7
	3.5	13	2.4	2.9	3.6	1509	4.1
	3.0	11	2.1	2.5	3.1	1294	3.5
231, 237	2.3	9	1.6	1.9	2.4	1725	Direct Drive
241, 247	3.6	15	2.5	3.0	N/A	1725	Direct Drive

See complete Drive Packages [Incls: Pulleys, Belts, Hubs, Key] Tech Bulletin 03.

"Customer confidence is our greatest asset"

PARTS LIST

ITEM	PART NUMBER						DESCRIPTION	QTY
	231,237	MATL	241,247	MATL	271,277	MATL		
2	30047	STL	30047	STL	30047	STL	Key (M5x5x24)	1
5	89618	S	89618	S	89618	S	Screw, HH (M6x16)	8
6	15849	S	15849	S	15849	S	Lockwasher, Split (M6)	4
7	19933	S	19933	S	19933	S	Washer (M6)	8
8	27950	AL	27950	AL	27950	AL	Cover, Bearing	2
10	26536	NBR	26536	NBR	26536	NBR	O-Ring, Bearing Cover - 70	2
11	24159	NBR	24159	NBR	24159	NBR	Seal, Oil	2
15	14487	STL	14487	STL	14487	STL	Bearing, Ball	2
20	101799	ZZ	101799	ZZ	101799	ZZ	Rod, Connecting Assy	3
25	44917	FCM	44193	FCM	43897	FCM	Crankshaft, Dual End	1
31	828710		828710		828710		Protector, Oil Cap	1
32	43211		43211		43211		Cap, Oil Filler	1
33	14177	NBR	14177	NBR	14177	NBR	O-Ring, Oil Filler Cap - 70	1
37	43987		43987		43987		Gauge, Oil Bubble	1
38	44428	NBR	44428	NBR	44428	NBR	Gasket, Flat, Flex, Oil Gauge - 80	1
40	92542	SS	92542	SS	92542	SS	Screw, Sems HHC (M6x20)	6
48	25625	STCP	25625	STCP	25625	STCP	Plug, Drain (1/4"x11)	1
49	23170	NBR	23170	NBR	23170	NBR	O-Ring, Drain Plug	1
50	43339	AL	43339	AL	43339	AL	Cover, Crankcase	1
51	43340	NBR	43340	NBR	43340	NBR	O-Ring, Cover	1
53	44657	AL	44657	AL	44657	AL	Crankcase, 4 Screw, Large Cap	1
64	16948	S	16948	S	16948	S	Pin, Rist	3
65	45114	SSZZ	45114	SSZZ	45114	SSZZ	Rod, Plunger	3
69	20017	STL	20017	STL	20017	STL	Washer, Back-up (M24x1.2)	3
70	25301	NBR	25301	NBR	25301	NBR	Seal, Oil - 80	3
71	26854	S	26854	S	26854	S	Washer, Oil Seal	3
75	43900	S	43900	S	43900	S	Slinger, Barrier	3
88	45697	S	45697	S	45697	S	Washer, Keyhole (M18)	3
90	43901	CC	43901	CC	43901	CC	Plunger (M43)	3
95	89652	SS	89652	SS	89652	SS	Stud, Plunger Retainer (M6x43)	3
96	43235	PTFE	43235	PTFE	43235	PTFE	Back-up-Ring, Plunger Retainer	3
97	17399	NBR	17399	NBR	17399	NBR	O-Ring, Plunger Retainer - 80	3
	14160	FPM	14160	FPM	14160	FPM	O-Ring, Plunger Retainer	3
	◆ 46204	EPDM	◆ 46204	EPDM	◆ 46204	EPDM	O-Ring, Plunger Retainer	3
98	44041	SS	44041	SS	44041	SS	Gasket, Plunger Retainer (M12.5)	3
99	44031	SS	44031	SS	44031	SS	Retainer, Plunger (M6)	3
100	28597	PVDF	28597	PVDF	28597	PVDF	Retainer, Seal	3
106	44053	NBR	44053	NBR	44053	NBR	Seal, LPS w/SS-Spg	3
	44926	FPM	44926	FPM	44926	FPM	Seal, LPS w/S-Spg	3
	◆ 46651	EPDM	◆ 46651	EPDM	◆ 46651	EPDM	Seal, LPS w/S-Spg	3
● 110	44052	NAB	44052	NAB	44052	NAB	Manifold, Inlet	1 ●
	46425	SS	46425	SS	46425	SS	Manifold, Inlet	1 ●
116	15847	S	15847	S	15847	S	Lockwasher, Split (M10)	2
117	87950	S	87950	S	87950	S	Screw, HSH (M10x35)	2
125	44652	NBR	44652	NBR	44652	NBR	Seal, HPS w/SS	3
	44925	FPM	44925	FPM	44925	FPM	Seal, HPS w/SS	3
	◆ 46652	HT	◆ 46652	HT	◆ 46652	HT	Seal, HPS	3
139	44563	NAB	44563	NAB	44563	NAB	Plug, Inlet (1/2" NPT)	1
	45156	SS	45156	SS	45156	SS	Plug, Inlet (1/2" NPT)	1
143	17547	NBR	17547	NBR	17547	NBR	O-Ring, Adapter, Inner - 85	3
	11685	FPM	11685	FPM	11685	FPM	O-Ring, Adapter, Inner	3
	◆ 46648	EPDM	◆ 46648	EPDM	◆ 46648	EPDM	O-Ring, Adapter, Inner	3
150	44060	SS	44060	SS	44060	SS	Adapter, Inlet Valve	3
154	43893	NBR	43893	NBR	43893	NBR	O-Ring, Adapter, Outer - 80	3
	44927	FPM	44927	FPM	44927	FPM	O-Ring, Adapter, Outer	3
	◆ 46649	EPDM	◆ 46649	EPDM	◆ 46649	EPDM	O-Ring, Adapter, Outer	3
155	26089	NBR	26089	NBR	26089	NBR	O-Ring, Spacer - 80	3
	11377	FPM	11377	FPM	11377	FPM	O-Ring, Spacer	3
	◆ 46647	EPDM	◆ 46647	EPDM	◆ 46647	EPDM	O-Ring, Spacer	3
157	44059	SS	44059	SS	44059	SS	Spacer, Discharge Valve	3
159	26089	NBR	26089	NBR	26089	NBR	O-Ring, Spacer - 80	3
	11377	FPM	11377	FPM	11377	FPM	O-Ring, Spacer	3
	◆ 46647	EPDM	◆ 46647	EPDM	◆ 46647	EPDM	O-Ring, Spacer	3
164	44058	SS	44058	SS	44058	SS	Seat	6
165	44001	NBR	44001	NBR	44001	NBR	O-Ring, Seat - 80	6
	44928	FPM	44928	FPM	44928	FPM	O-Ring, Seat	6
	◆ 46650	EPDM	◆ 46650	EPDM	◆ 46650	EPDM	O-Ring, Seat	6
166	44057	SS	44057	SS	44057	SS	Valve	6
167	44056	SS	44056	SS	44056	SS	Spring	6
168	44055	SS	44055	SS	44055	SS	Retainer, Spring	6
● 185	44054	NAB	44054	NAB	44054	NAB	Manifold, Discharge	1 ●
	46427	SS	46427	SS	46427	SS	Manifold, Discharge	1 ●
186	15847	S	15847	S	15847	S	Lockwasher, Split (M10)	4
188	87952	S	87952	S	87952	S	Screw, HSH (M10x55)	4
250	25130	STCP	25130	STCP	25130	STCP	Protector, Shaft	1
260	30612	STZP	30612	STZP	30612	STZP	Rail, Angle Assy (Incls: 26246,30901,30910,30920)	1
265	30651		30651		30651		Kit, Complete Mounting (30612,30246,25130)	1
270	30246	STL	30246	STL	30246	STL	Pulley & Key Assy (Incls: 30032,30047)	1
							[See complete Drive Packages, Tech Bulletin 03]	
277	34121	AL	34121	AL	34121	AL	Bell Housing Assy (56C-145FR, 1.5 HP)	1
	34126	AL	34126	AL	34126	AL	Bell Housing Assy (182TC-184TC, 3.0 HP)	1
278	34394	AL	34394	AL	34394	AL	Flexible Coupling Assy (M16.5 to 5/8")	1
	34395	AL	34395	AL	34395	AL	Flexible Coupling Assy (M16.5 to 1-1/8")	1

EXPLODED VIEW

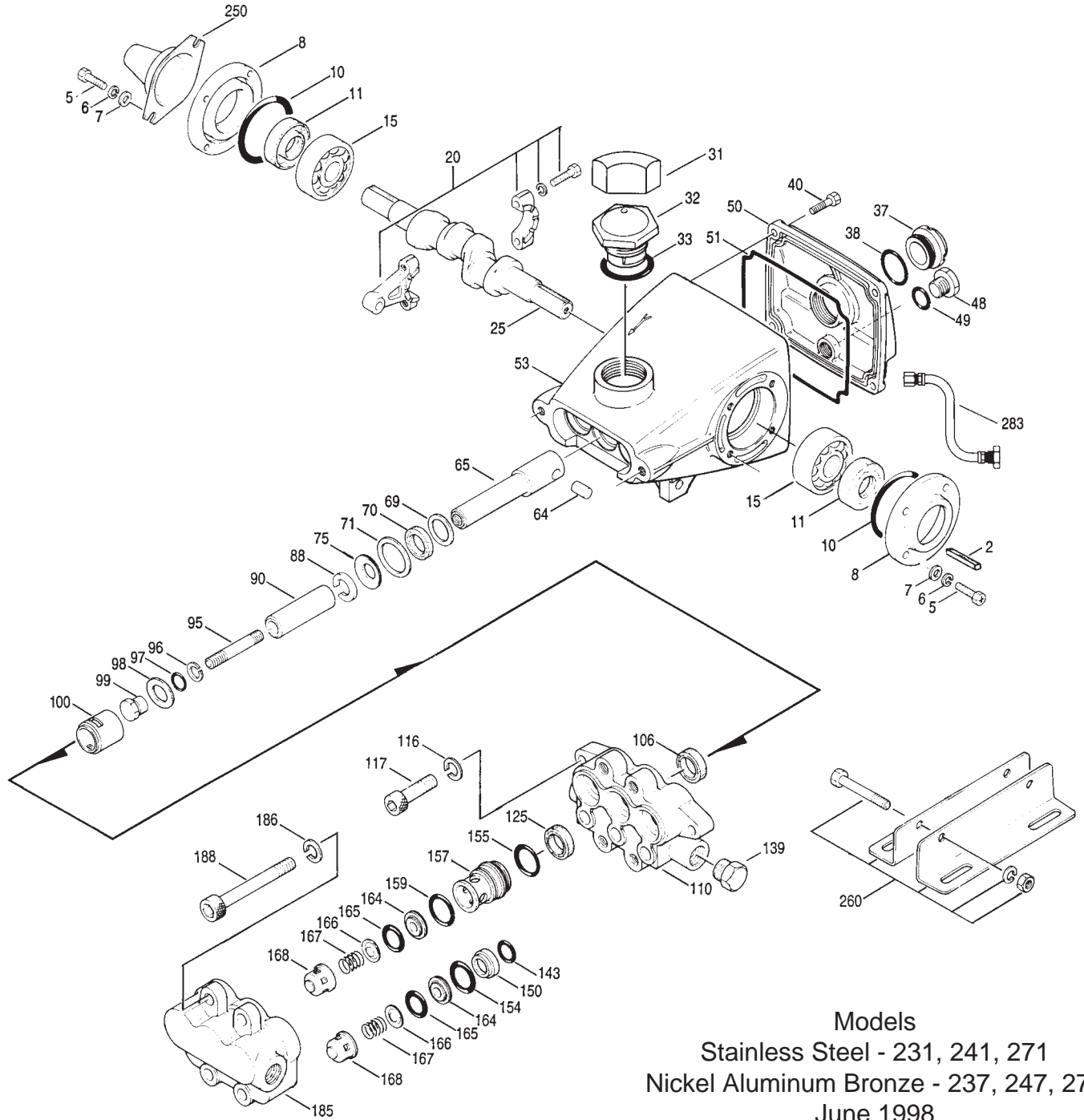

Models
 Stainless Steel - 231, 241, 271
 Nickel Aluminum Bronze - 237, 247, 277
 June 1998

● 283	34334	34334	34334	34334	Kit, Oil Drain	1 ●
● 299	815262	NAB	815262	NAB	Head, Complete	1 ●
●	814823	SS	814823	SS	Head, Complete	1 ●
306	30983	NBR	30983	NBR	Kit, Seal (Incls: 97,106,125,143,154,155, 159)	1
	33609	FPM	33609	FPM	Kit, Seal (Incls: 97,106,125,143,154,155,159)	1
	◆ 33914	EPDM	◆ 33914	EPDM	Kit, Seal (Incls: 97,106,125,143,154,155,159)	1
310	30982	SS	30982	SS	Kit, Valve (Incls: 143,154,155,164,165,166,167,168)	1
	31216	FPM	31216	FPM	Kit, Valve (Incls: 143,154,155,164,165,166,167,168)	1
	◆ 31217	EPDM	◆ 31217	EPDM	Kit, Valve (Incls: 143,154,155,164,165,166,167,168)	1
350	30696	STZP	30696	STZP	Tool, Valve Seat Removal	1
351	43257	STZP	43257	STZP	Tool, Seal Case Removal	1
● 390	—	—	—	—	C.A.T. (For R.O. or Industrial Applications)	1 ●
● 391	—	—	—	—	Adapter (2 per C.A.T.) (See Data Sheet for complete selection)	2 ●
—	6565.2	6565.2	6565.2	6565.2	Plunger Pump Service Video	1

● Industrial discount. **Bold print part numbers are unique to a particular pump model. Italics are optional items.** ◆ Silicone oil/grease required.

Pressurized inlet and C.A.T. highly recommended for Hi-Temp, R.O. and industrial applications.

See Tech Bulletins 03, 08, 24, 33, 34, 36, 43, 47, 49, 52, 53, 67, 73, 74 and 77 for additional information. Add .3000 to part number for Hi-Temp models.

MATERIAL CODES (Not Part of Part Number): AL=Aluminum CC=Ceramic EPDM=Ethylene Propylene Diene Monomer FCM=Forged Chrome-moly
 FPM=Fluorocarbon (Viton®) HT=Hi-Temp (EPDM Alternative) NAB=Nickel Aluminum Bronze NBR=Medium Nitrile (Buna-N)
 PTFE=Polytetrafluoroethylene (Teflon®) PVDF=Fluoroplastic (High Strength) S=304SS SS=316SS SSZZ=316SS/Zamak
 STCP=Steel/Chrome Plated STL=Steel STZP=Steel/Zinc Plated ZZ=Zamak

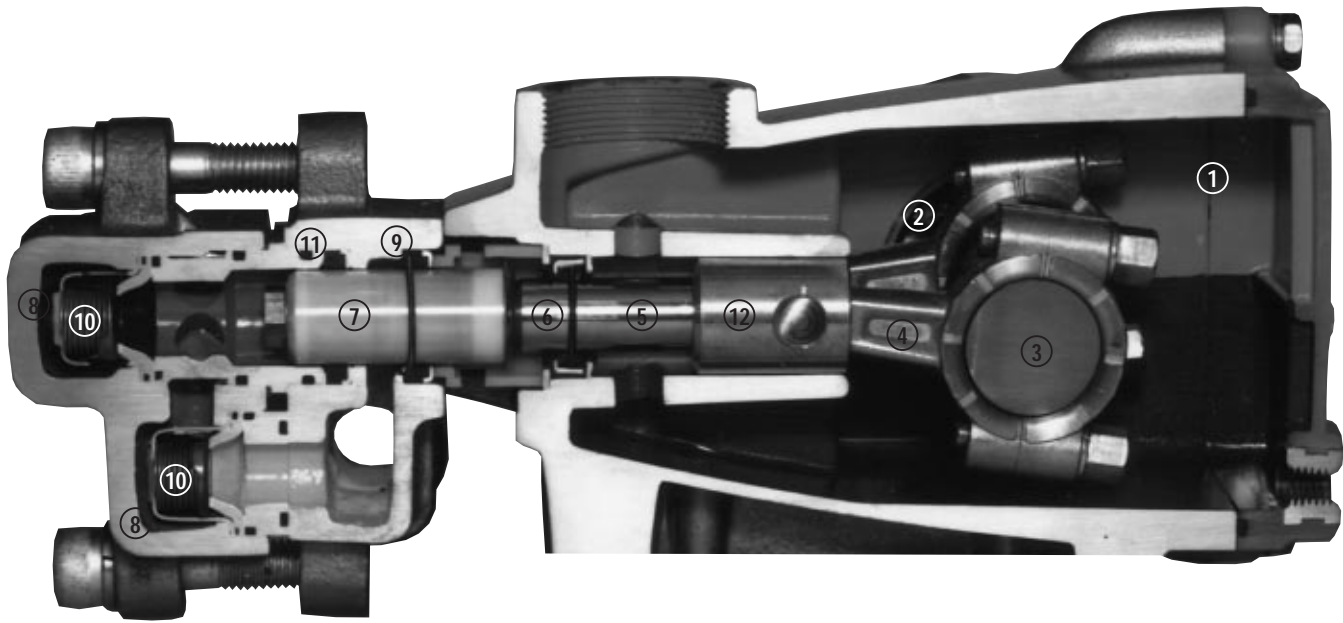
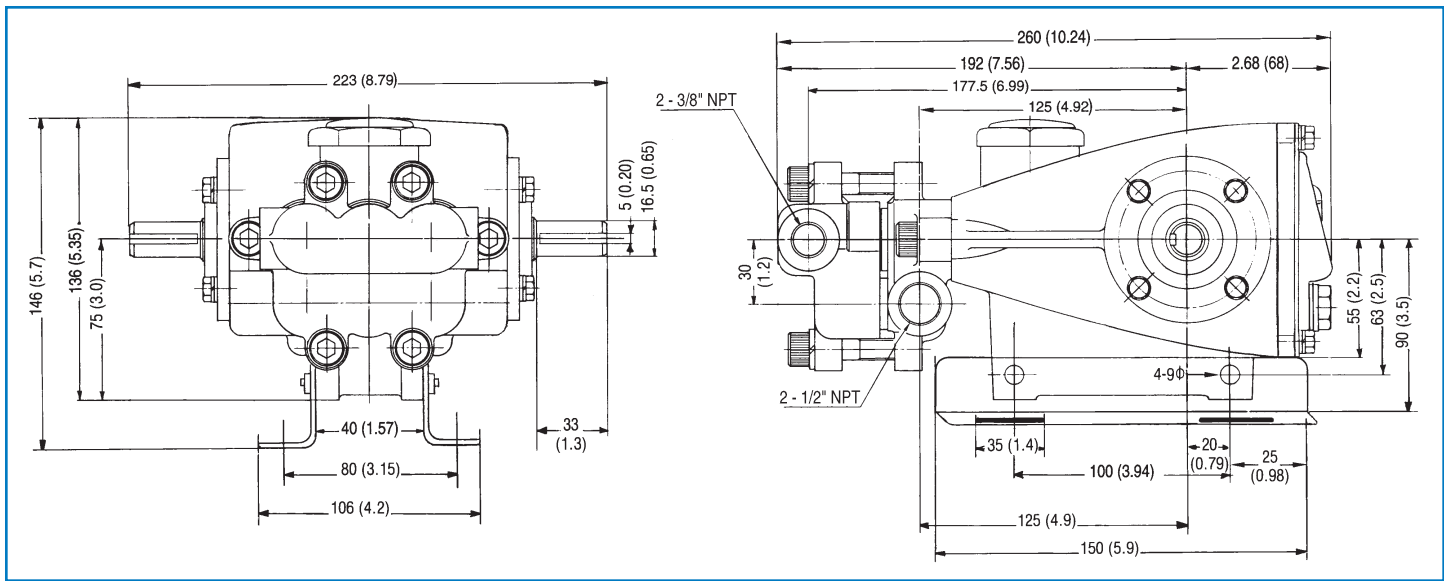

- 1 Die cast aluminum **crankcase** means high strength, lightweight, and excellent tolerance control.
- 2 Oversized crankshaft **bearings** provide extended bearing life and pump performance.
- 3 Chrome-moly **crankshaft** provides unmatched strength and surface hardness for long life.
- 4 Matched oversized **connecting rods** are made of Zamak, a material noted for strength and superior bearing quality.
- 5 The **plunger rods** are high tensile strength stainless steel with Zamak crossheads.
- 6 The stainless steel **slinger** provides back-up protection for the crankcase seal, keeping pumped fluids out of the crankcase.
- 7 Special concentric, high density, polished, graphite impregnated, solid ceramic **plungers** are abrasion resistant and result in extended seal life.
- 8 **Manifolds** are a high tensile strength 316 stainless steel or nickel aluminum bronze for long term, continuous duty.
- 9 100% wet **seal** design adds to service life by allowing pumped fluids to cool and lubricate on both sides.
- 10 Stainless steel **valves, seats and springs** provide corrosion-resistance, positive seating and long life.
- 11 Specially formulated, CAT PUMP exclusive, **Hi-Pressure Seals** offer unmatched performance and seal life.
- 12 **Crossheads** are 360° supported for uncompromising alignment.

Products described hereon are covered by one or more of the following U.S. patents 3558244, 3652188, 3809508, 3920356, 3930756 and 5035580

June 1998 4869

World Headquarters

CAT PUMPS

1681 - 94th Lane N.E. Minneapolis, MN 55449-4324

Phone (612) 780-5440 — FAX (612) 780-2958

e-mail: sales@catpumps.com

www.catpumps.com

International Inquiries

FAX (612) 785-4443

e-mail: intlsales@catpumps.com



The Pump with "Nine Lives"

CAT PUMPS (U.K.) LTD.

1 Fleet Business Park, Sandy Lane, Church Crookham, Fleet

Hampshire GU13 0BF, England

Phone Fleet 44 1252-622031 — Fax 44 1252-626655

N.V. CAT PUMPS INTERNATIONAL S.A.

Heiveldekens 6A, 2550 Kontich, Belgium

Phone 32-3-450.71.50 — Fax 32-3-450.71.51

e-mail: cpi@catpumps.be

CAT PUMPS DEUTSCHLAND GmbH

Buchwiese 2, D-65510 Idstein, Germany

Phone 49 6126-93030 — Fax 49 6126-930333

e-mail: catpumps@t-online.de