



Model 1CX05ELSD501
Motor-Pump-Unit
Without Pulse Hose

FEATURES

- Ultra-compact, direct-drive motor-pump-unit for portability and small spaces.
- Four-position head mounting for plumbing flexibility.
- Industrial stacked valves provide easy servicing.
- Concentric ceramic plunger and specially formulated seals provide extended seal life.
- Oil bath lubrication assures optimum drive-end lubrication.
- Pressure regulator offers precision pressure setting and over-pressure protection.
- Pulse Hose minimizes pulsation and lowers amp draw.

COMMON SPECIFICATIONS

Maximum RPM.....	1725 rpm	(1725 rpm)
Inlet Pressure Range.....	Flooded to 60 psi	(Flooded to 4 bar)
Bore.....	0.630"	(16 mm)
Crankcase Capacity.....	2.03 oz.	(0.06 l)
Maximum Liquid Temperature.....	up to 140°F	(up to 60°C)
Inlet Port.....	3/8" NPTF	(3/8" NPTF)
Discharge Port.....	1/4" NPTF	(1/4" NPTF)
By-Pass Port.....	1/4" NPTF	(1/4" NPTF)
Shaft Diameter.....	1/2"	(12.7 mm)
Weight (Pump Only).....	3.45 lbs.	(1.56 kg)
Dimensions (Pump Only).....	3.62 x 5.12 x 6.85"	(92 x 130 x 174 mm)

⚠ CAUTIONS AND WARNINGS

All High Pressure Systems require a primary pressure regulating device (i.e. regulator, unloader) and a secondary pressure relief device (i.e. pop-off valve, relief valve). Failure to install such relief devices could result in personal injury or damage to pump or property. CAT PUMPS does not assume any liability or responsibility for the operation of a customer's high pressure system.

Read all CAUTIONS and WARNINGS before commencing service or operation of any high pressure system. The CAUTIONS and WARNINGS are included in each service manual and with each Accessory Data sheet. CAUTIONS and WARNINGS can also be viewed online at www.catpumps.com/cautions-warnings or can be requested directly from CAT PUMPS.

WARRANTY

View the Limited Warranty on-line at www.catpumps.com/warranty.

Direct-Drive Misting Motor-Pump-Units

MPU Models With Pulse Hose

1CX013ELSPD251
1CX025ELSPD251
1CX05ELSPD501

MPU Models Without Pulse Hose

1CX013ELSD251
1CX025ELSD251
1CX05ELSD501

SPECIFICATIONS

U.S. Measure Metric Measure

MPU MODEL 1CX013ELSPD251 or 1CX013ELSD251

PUMP MODEL 1CX013ELS.MIST

Flow.....	0.13 gpm	(0.49 lpm)
Pressure Range.....	100 to 1000 psi	(7 to 70 bar)
Stroke (Single Plunger).....	0.079"	(2.0 mm)

MPU MODEL 1CX025ELSPD251 or 1CX025ELSD251

PUMP MODEL 1CX025ELS.MIST

Flow.....	0.25 gpm	(0.95 lpm)
Pressure Range.....	100 to 1000 psi	(7 to 70 bar)
Stroke (Single Plunger).....	0.130"	(3.3 mm)

MPU MODEL 1CX05ELSPD501 or 1CX05ELSD501

PUMP MODEL 1CX05ELS.MIST

Flow.....	0.50 gpm	(1.89 lpm)
Pressure Range.....	100 to 1000 psi	(7 to 70 bar)
Stroke (Single Plunger).....	0.248"	(6.3 mm)

ELECTRIC HORSEPOWER REQUIREMENTS

MODEL	FLOW		PRESSURE			RPM
			psi 500	psi 800	psi 1000	
	U.S. gpm	lpm	bar 35	bar 55	bar 70	
1CX013ELSPD251	0.13	0.49	.06	.10	.12	1725
1CX025ELSPD251	0.25	0.95	.12	.19	.24	1725
1CX05ELSPD501	0.50	1.89	.24	.38	.47	1725

$$\text{DETERMINING THE REQUIRED H.P.} = \frac{\text{gpm} \times \text{psi}}{1060} = \text{Electric Brake H. P. Required}$$

Refer to pump **Service Manual** for repair procedure and additional technical information.

EXPLODED VIEW

September 2012

PLUNGER PUMP MODELS

1CX013ELSPD251, 1CX025ELSPD251, 1CX05ELSPD501

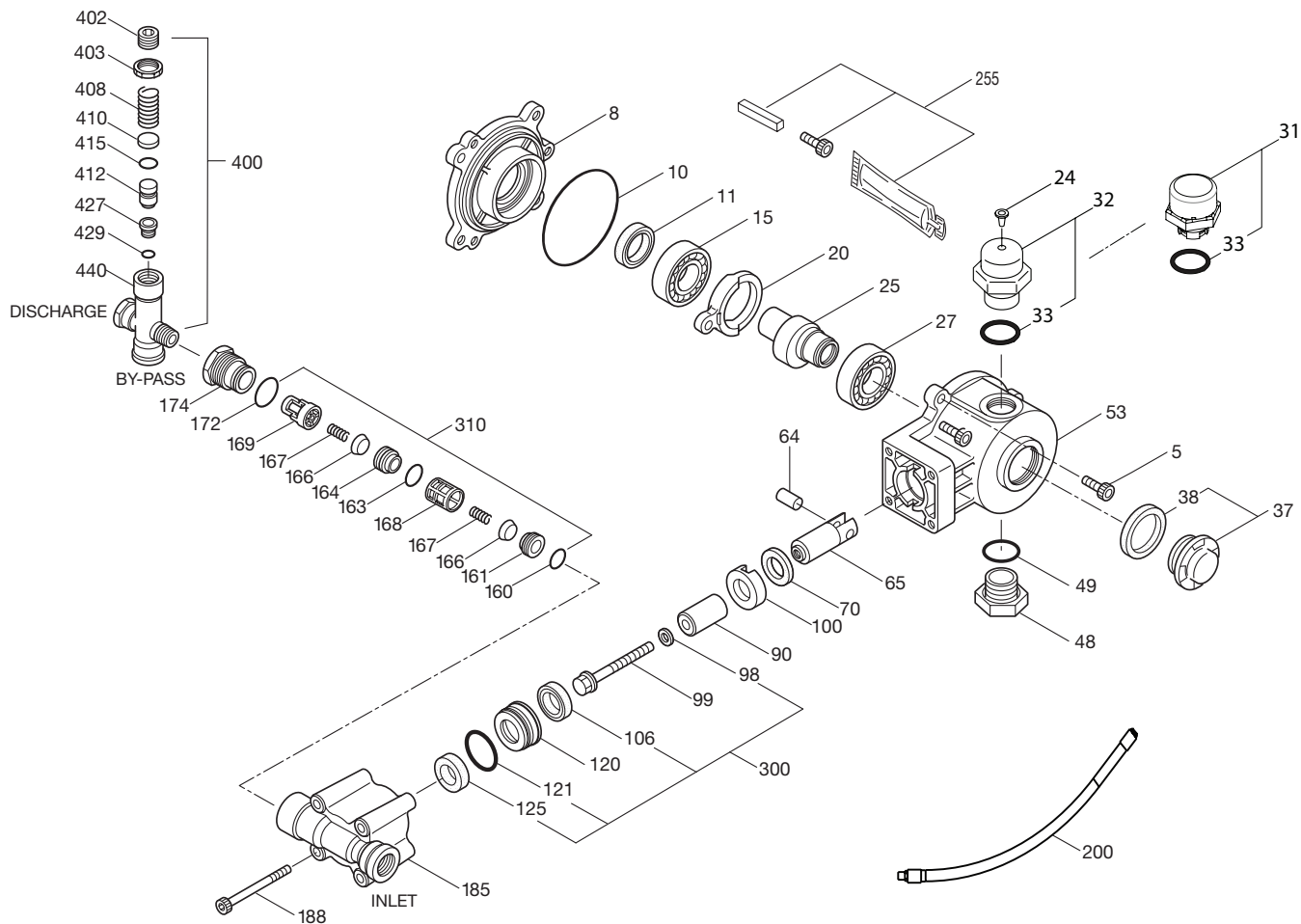

PARTS LIST

ITEM	P/N	MATL	DESCRIPTION	QTY	ITEM	P/N	MATL	DESCRIPTION	QTY
2	76059	STL	Key (1/8 sq x 1.5") (Included in 30555)	1	160	13965	NBR	O-Ring, Inlet Seat - 70D	1
5	180318	STCP R	Screw, Bearing Cover (M6x14)	3	161	545177	S	Seat, Inlet	1
8	49563	AL	Cover, Bearing	1	163	19285	NBR	O-Ring, Discharge Seat - 70D	1
10	14035	NBR	O-Ring, Bearing Cover - 70D	1	164	545178	S	Seat, Discharge	1
11	49565	NBR	Seal, Oil - 70D	1	166	46764	S	Valve	2
15	47862	STL	Bearing, Inner Ball	1	167	46865	S	Spring	2
20	49566	TNM	Rod, Connecting	1	168	543988	PVDF	Retainer, Inlet Spring	1
24	549608	LDPE	Plug, Oil Cap (remove before startup)	1	169	49569	PVDF	Retainer, Discharge Spring	1
25	49560	STL	Crankshaft - 1CX05ELS, 6.3 mm	1	172	11346	NBR	O-Ring, Discharge Fitting - 70D	1
	49602	STL	Crankshaft - 1CX013ELS, 2.0 mm	1	174	49570	BB	Plug, Valve w/1/4" NPTF Port	1
	49598	STL	Crankshaft - 1CX025ELS, 3.3 mm	1	185	49515	BB	Head, Manifold	1
27	47862	STL	Bearing, Outer Ball	1	188	89953	STCP	Screw, HSH (M6x55)	4
31	129254	ABS	Cap, Rain Proof w/O-Ring	1	200	76225	—	Hose, Pulse (3/8" x 24")	1
32	49557	ABS	Cap, Oil Filler w/O-Ring	1	255	30555	STZP R	Assy, Bolt Mount	1
33	14179	NBR	O-Ring, Oil Filler Cap - 70D	1	300	76063	NBR	Kit, Seal (Incls: 98, 106, 121, 125)	1
37	92241	—	Gauge, Bubble Oil w/Gasket - 80D	1	310	76033	NBR	Kit, Valve	1
38	44428	NBR	Gasket, Flat Flex, Oil Gauge - 80D	1				(Incls: 160, 161, 163, 164, 166, 167, 168, 169, 172)	
48	44842	NY	Plug, Drain	1	400	7555	BB	Regulator	1
49	14179	NBR	O-Ring, Drain Plug - 70D	1	402	49681	BB	Cap, Hex Adjusting	1
53	49554	AL	Crankcase	1	403	49682	BB	Nut, Locking	1
64	46229	STL	Pin, Crosshead	1	408	49876	STZP	Spring	1
65	542402	BB	Rod, Plunger	1	410	549352	STCP R	Retainer, Spring	1
70	47215	NBR	Seal, Oil - 70D	1	412	49877	S	Stem, Piston	1
90	542403	CC	Plunger (M16x27)	1	415	14759	NBR	O-Ring, Piston Stem - 70D	1
98	46730	NBR	Washer, Seal - 90D	1	427	49878	S	Seat	1
99	542405	S	Retainer, Plunger (M6x35)	1	429	25300	NBR	O-Ring, Seat - 70D	1
100	46233	D	Retainer, Seal	1	440	—	BB	Body	1
106	48222	NBR	Seal, LPS w/S-Spg - 85D	1	468	31555	NBR	Kit, O-Ring (Incls: 172, 415, 429)	1
120	547357	BB	Case, Seal	1				See Back Page For Motors	
121	13976	NBR	O-Ring, Seal Case - 70D	1					
125	46240	NBR	Seal, HPS w/S - 85D	1					

Bold part numbers are unique to a particular pump model. Italics are optional items. R Components comply with RoHS Directive.

See Tech Bulletins 002, 024, 036, 043, 074 and 083 for additional information.

MATERIAL CODES (Not Part of Part Number): ABS=ABS Plastic AL=Aluminum BB=Brass CC=Ceramic D=Acetal
 LDPE=Low Density Polyethylene NBR=Medium Nitrile (Buna-N) NY=Nylon PVDF=Polyvinylidene Fluoride S=304SS STCP=Steel/Chrome Plated
 STL=Steel STZP=Steel/Zinc Plated TNM=Special High Strength

OPERATION:

A pressure regulator is included with each 1CX plunger pump. The regulator is not pre-set at the factory. Set system pressure once the system is started. Start at the lowest pressure reading and adjust the hex adjusting cap in small increments until the desired system pressure is attained. Remember to service the regulator on the same schedule as the pump seals and valves. Refer to 1CX service manual for start-up, servicing of seals and valves, torque requirements and diagnosis/maintenance chart.

INLET:

It is recommended to install a flexible hose at the pump inlet. Assure flooded or up to 60 psi inlet pressure for optimum performance. Install an inlet filter to remove standard water debris.

DISCHARGE:

All discharge plumbing for the 1CX pump connects to the regulator outlet port.

PULSE HOSE MOUNTING:

Mount the pulse hose by installing a tee fitting into the regulator outlet port. Install the pulse hose into the top port. Coil hose and tie wrap as shown. Add nipple with a tee to mount pressure gauge. The other end of the pulse hose is plugged to capture the pulse.

Note: Without a pulse hose, the pump may draw as much as 2 additional AMPS above full load AMPS.

BY-PASS:

The regulator by-pass is at the bottom. Connect a 1/4" flexible hose and route to inlet of pump, to tank, or to drain.

NOTICE:

By-pass to the pump inlet is designed for cold water or ambient temperature operation.

DO NOT EXCEED 6 MINUTES IN BY-PASS

operation. Excessive temperatures will cause premature wear or damage to the pump and **VOID THE WARRANTY.**

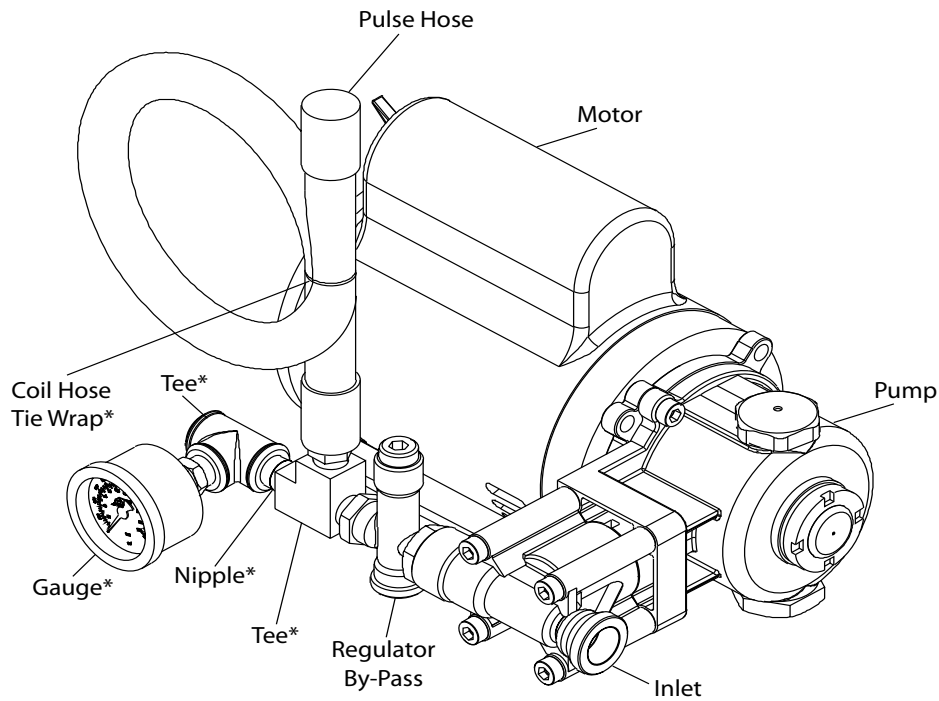

Typical Set-Up (*Not Supplied With Motorized Pump Unit)

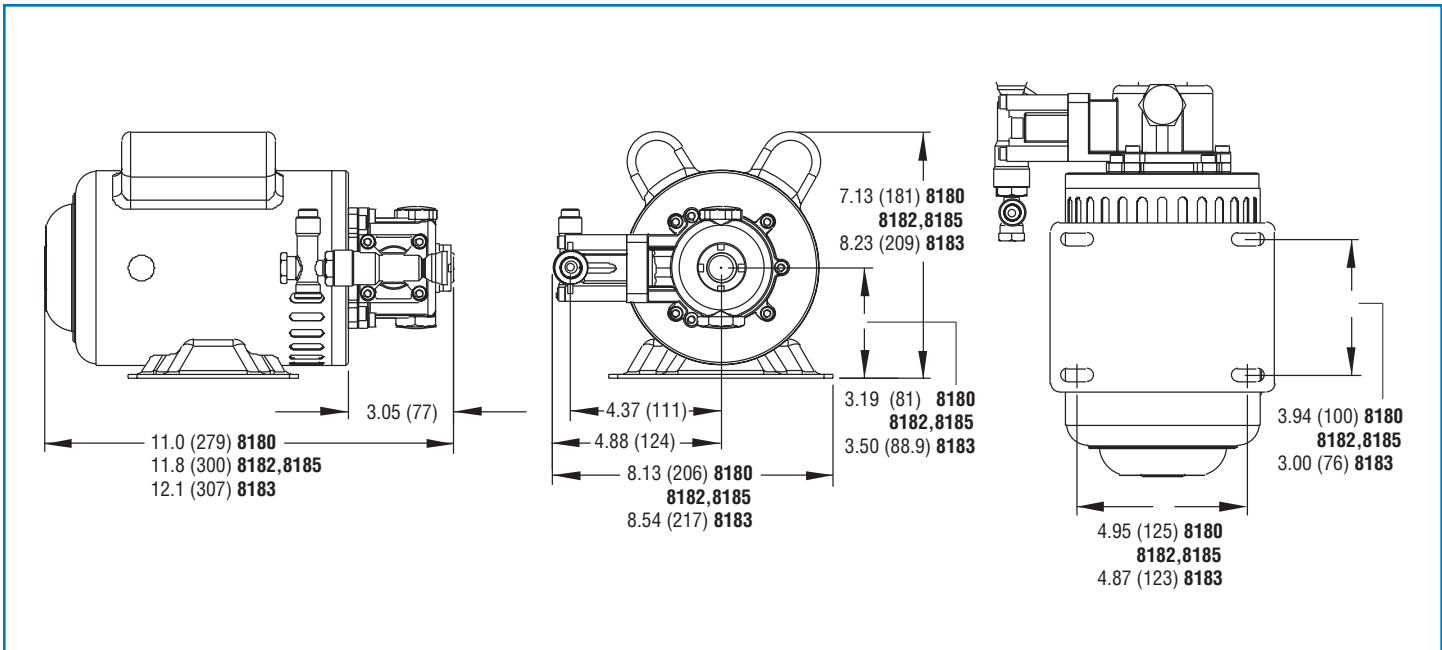

MOTOR-PUMP-UNITS	1CX013ELSPD251	1CX025ELSPD251	1CX05ELSPD501
Weight	19.72 lbs	19.72 lbs	25.67 lbs

MOTORS	8180	8182	8183	8185 w/Box
Horsepower	1/4 Hp	1/2 Hp	1/2 Hp	1/2 Hp
Phase	Single	Single	Single	Single
Hertz	60 Hz	60 Hz	50 Hz	60 Hz
Voltage	115V / 230V	115V / 230V	115V / 230V	115V / 230V
rpm	1750 rpm	1750 rpm	1450 rpm	1750 rpm
Full Load AMP*	2.8 / 1.4	4.8 / 2.4	6.4 / 3.2	4.8 / 2.4
Service Factor	1.0	1.0	1.0	1.0
Shaft Diameter	1/2"	1/2"	1/2"	1/2"
Capacitors	Start and Run	Start and Run	Start and Run	Start and Run
Insulation Class	E	E	F	E
Motor Type	ODP	ODP	TEFC	ODP
Compliance	RoHS CSA	RoHS CSA	RoHS, CE UL, CSA	RoHS CSA
Weight	15.80 Lbs.	21.75 Lbs.	28.85 Lbs.	22.25 Lbs.

*NOTE: Without pulse hose AMP draw will increase as much as 2 AMPS depending upon pump model and discharge pressure.



CAT PUMPS
 1681 - 94TH LANE N.E. MINNEAPOLIS, MN 55449-4324
 PHONE (763) 780-5440 — FAX (763) 780-2958
 e-mail: techsupport@catpumps.com
 www.catpumps.com