

18 Frame Block-Style Stainless Steel Plunger Pump

Standard Models 1851, 1861

Flushed Models 1851K, 1861K

FEATURES

Superior Design

- Triplex plunger design gives smoother liquid flow.
- Inlet and discharge valve assemblies interchange for easier maintenance.
- Oil bath crankcase assures optimum lubrication.
- Close tolerance concentricity of the ceramic plunger maximizes seal life.
- **Standard Models:** Lo-Pressure Seals and V-Packings are completely lubricated and cooled by the liquid being pumped.
- **Flushed Models:** Special ported inlet manifold permits liquid to cool or flush between V-Packings and the Lo-Pressure Seals, providing protection against high temperature and contaminating pumped liquids.

Quality Materials

- Precision design 316 stainless steel valves and seats are hardened and polished for ultimate seating and extended valve life.
- 316 SSL block-style manifolds for strength and corrosion resistance.
- Special concentric, high density, polished graphite impregnated, solid ceramic plungers are abrasion resistant and result in extended seal life.
- Specially formulated, CAT PUMP exclusive, V-Packings offer unmatched performance and seal life.
- Die cast aluminum crankcase provides high strength, minimum weight and precision tolerance control.
- Chrome-moly crankshaft gives unmatched strength and surface hardness.
- Oversized crankshaft bearings with greater loading capacity mean longer bearing life.

Easy Maintenance

- Wet-end is easily serviced without entering crankcase, requiring less time and effort.
- Preset packings mean no packing gland adjustment is necessary, reducing maintenance costs.

⚠ WARNING

All systems require both a primary pressure regulating device (i.e., regulator, unloader) and a secondary pressure safety relief device (i.e., pop-off valve, safety valve). Failure to install such relief devices could result in personal injury or damage to the pump or to system components. CAT PUMPS does not assume any liability or responsibility for the operation of a customer's high pressure system.

SPECIFICATIONS

U.S. Measure

Metric Measure

MODEL 1851, 1851K

Flow	10 GPM	(38 L/M)
Pressure Range	100 to 2200 PSI	(7 to 155 BAR)
Bore	0.945"	(24 mm)
RPM	958 RPM	(958 RPM)
Inlet Pressure Range*	-5 to 60 PSI	(-0.35 to 4 BAR)

Alternate Specifications

Flow**	12 GPM	(45 L/M)
Pressure Range**	100 to 1800 PSI	(7 to 125 BAR)
RPM**	1150 RPM	(1150 RPM)
Inlet Pressure**20 to 60 PSI	(1.4 to 3.4 BAR)
Maximum Liquid Temperature**	100°F	(38°C)

MODEL 1861, 1861K

Flow	10.0 GPM	(38 L/M)
Pressure Range	100 to 3000 PSI	(7 to 210 BAR)
Bore	0.787"	(20 mm)
RPM	1429 RPM	(1429 RPM)
Inlet Pressure Range*	+10 to 60 PSI	(0.70 to 4 BAR)

COMMON SPECIFICATIONS

Stroke	1.180"	(30 mm)
Crankcase Capacity	42 oz.	(1.26 L)
Maximum Liquid Temperature	160°F	(71°C)
Above 130°F call CAT PUMPS for inlet conditions and elastomer recommendations.		
Inlet Ports (2)	1" NPTF	(1" NPTF)
Flushing Ports (2)*	1/4" NPTF	(1/4" NPTF)
Discharge Ports (2)	1/2" NPTF	(1/2" NPTF)
Pulley Mounting	Either Side	(Either Side)
Shaft Diameter	1.180"	(30 mm)
Weight	67 lbs.	(30.4 kg)
Dimensions	18.37 x 12.99 x 6.49"	(450 x 330 x 165 mm)

*"K" models have special inlet ports for cooling/flushing, containment of hazardous liquids and high inlet pressure. Contact CAT PUMPS for additional information.

** C.A.T. required.

HORSEPOWER REQUIREMENTS

MODEL	FLOW		PRESSURE					MOTOR PULLEY SIZE	
	U.S. GPM	L/M	PSI 1500	PSI 1800	PSI 2000	PSI 2200	PSI 2500	PSI 3000	Using 1725 RPM Motor & Std. 10.0" Pump Pulley
			BAR 105	BAR 125	BAR 140	BAR 155	BAR 175	BAR 210	RPM
1851	12.0	45	12.4	14.8	N/A	N/A	N/A	N/A	1150
1851K	10.0	38	10.3	12.4	13.7	15.1	N/A	N/A	958
1861	10.0	38	10.3	12.4	13.7	15.1	17.2	20.6	1429
1861K	9.0	34	9.3	11.1	12.4	13.6	15.4	18.5	1286

DETERMINING THE PUMP R.P.M. $\frac{\text{Rated G.P.M.}}{\text{Rated R.P.M.}} = \text{"Desired" G.P.M.}$

DETERMINING THE REQUIRED H.P. $\frac{\text{GPM} \times \text{PSI}}{1460} = \text{Electric Brake H. P. Required}$

DETERMINING MOTOR PULLEY SIZE $\frac{\text{Motor Pulley O.D.}}{\text{Pump R.P.M.}} = \frac{\text{Pump Pulley O.D.}}{\text{Motor R.P.M.}}$

See complete Drive Packages [Incls: Pulleys, Belts, Hubs, Key] Tech Bulletin 003.

Refer to pump Service Manual for repair procedure and additional technical information.

"Customer confidence is our greatest asset"

PARTS LIST

ITEM	PART NUMBER				DESCRIPTION	QTY
2	1851 MATL	1851K MATL	1861 MATL	1861K MATL	Key (M8x7.5x25)	1
5	30067 STL	30067 STL	30067 STL	30067 STL	Screw, Sems HHC (M6x16)	8
8	92538 S	92538 S	92538 S	92538 S	Cover, Bearing	2
9	43496 AL	43496 AL	43496 AL	43496 AL	Shim, Split 2-Pc, Bearing Cover	0/2
	43520 FBR	43520 FBR	43520 FBR	43520 FBR	Shim, Split 2-Pc, Bearing Cover	0/2
	45387 S	45387 S	45387 S	45387 S	O-Ring, Bearing Cover - 70D	2
10	11340 NBR	11340 NBR	11340 NBR	11340 NBR	Seal, Oil, Crankshaft - 70D	2
11	43495 NBR	43495 NBR	43495 NBR	43495 NBR	Bearing, Roller	2
15	39060 STL	39060 STL	39060 STL	39060 STL	Rod, Connecting Assy [11/00]	3
20	48600 TNM	48600 TNM	48600 TNM	48600 TNM	Crankshaft, Dual End	1
25	43494 FCM	43494 FCM	43494 FCM	43494 FCM	Protector, Oil Cap	1
31	828710 —	828710 —	828710 —	828710 —	Cap, Oil Filler	1
32	43211 ABS	43211 ABS	43211 ABS	43211 ABS	O-Ring, Filler Cap - 70D	1
33	14177 NBR	14177 NBR	14177 NBR	14177 NBR	Gauge, Oil, Bubble w/Gasket - 80D	1
37	92241 —	92241 —	92241 —	92241 —	Gasket, Flat, Oil Gauge - 80D	1
38	44428 NBR	44428 NBR	44428 NBR	44428 NBR	Screw, Sems HHC (M6x20)	4
40	92542 S	92542 S	92542 S	92542 S	Plug, Drain (1/4"x19 BSP)	1
48	25625 STCP	25625 STCP	25625 STCP	25625 STCP	O-Ring, Drain Plug - 70D	1
49	23170 NBR	23170 NBR	23170 NBR	23170 NBR	Cover, Rear	1
50	43491 AL	43491 AL	43491 AL	43491 AL	O-Ring, Rear Cover - 70D	1
51	44834 NBR	44834 NBR	44834 NBR	44834 NBR	Crankcase w/Guide Pins	1
53	43488 AL	43488 AL	43488 AL	43488 AL	Pin, Guide	2
54	27488 S	27488 S	27488 S	27488 S	Stud, Manifold (M10x180)	4
55	701268 SS	701268 SS	701268 SS	701268 SS	Pin, Crosshead	3
64	43507 CM	43507 CM	43507 CM	43507 CM	Rod, Plunger [3/02]	3
65	45258 SSZZ	45258 SSZZ	48892 SSHS	48892 SSHS	Washer, Seal, Flat	3
69	43504 STZP	43504 STZP	43504 STZP	43504 STZP	Seal, Oil, Crankcase - 80D	3
70	43500 NBR	43500 NBR	43500 NBR	43500 NBR	Slinger, Barrier	3
75	43506 S	43506 S	43506 S	43506 S	Washer, Keyhole (M12)	3
88	45675 SS	45675 SS	45675 SS	45675 SS	Spacer, Collar	3
89	45879 SS	45879 SS	45880 SS	45880 SS	Plunger (M24x77) and (M20x77)	3
90	43552 CC	43552 CC	43300 CC	43300 CC	Stud, Plunger Retainer (M6x70)	3
95	89651 SS	89651 SS	89651 SS	89651 SS	Back-up-Ring, Plunger Retainer	3
96	43235 PTFE	43235 PTFE	43235 PTFE	43235 PTFE	O-Ring, Plunger Retainer - 80D	3
97	17399 NBR	17399 NBR	17399 NBR	17399 NBR	O-Ring, Plunger Retainer - 80D	3
	14160 FPM	14160 FPM	14160 FPM	14160 FPM	O-Ring, Plunger Retainer - 80D	3
	46204 EPDM	46204 EPDM	46204 EPDM	46204 EPDM	O-Ring, Plunger Retainer - 70D	3
98	44041 SS	44041 SS	44041 SS	44041 SS	Gasket, Plunger Retainer	3
99	44031 SS	44031 SS	44031 SS	44031 SS	Retainer, Plunger (M6)	3
100	43509 POP	43509 POP	43509 POP	43509 POP	Retainer, Seal	3
104	11379 NBR	11379 NBR	11379 NBR	11379 NBR	O-Ring, Inlet Adapter - 70D	3
	700134 FPM	700134 FPM	700134 FPM	700134 FPM	O-Ring, Inlet Adapter	3
	701491 EPDM	701491 EPDM	701491 EPDM	701491 EPDM	O-Ring, Inlet Adapter	3
105	701307 SS	701307 SS	701270 SSL	701270 SSL	Adapter, LPS	3
106	44035 NBR	44035 NBR	44071 NBR	44071 NBR	Seal, LPS w/SS-Spg	3
	44388 FPM	44388 FPM	44381 FPM	44381 FPM	Seal, LPS w/SS-Spg	3
	46208 EPDM	46208 EPDM	701974 SFTB*	701974 SFTB*	Seal, LPS w/SS-Spg	3
110	701299 SSL	—	701299 SSL	—	Manifold, Inlet, Block-Style	1
	—	701309 SSL	—	701309 SSL	Manifold, Inlet, Block-Style, Flushed	1
111	701342 SS	701342 SS	701342 SS	701342 SS	Plug, Inlet (1"NPT)	1
112	26969 NBR	26969 NBR	26969 NBR	26969 NBR	O-Ring, Spacer - 70D	15
	28459 FPM	28459 FPM	28459 FPM	28459 FPM	O-Ring, Spacer	15
	701863 EPDM	701863 EPDM	701863 EPDM	701863 EPDM	O-Ring, Spacer	15
113	28204 PTFE	28204 PTFE	28204 PTFE	28204 PTFE	Back-up-Ring, Spacer	12
114	701272 SS	701272 SS	701272 SS	701272 SS	Adapter, Valve, IMDM	6
122	—	—	43519 PTFE	43519 PTFE	Back-up-Ring, Spacer	3
123	26969 NBR	26969 NBR	13984 NBR	13984 NBR	O-Ring, Spacer - 70D	3
	28459 FPM	28459 FPM	14333 FPM	14333 FPM	O-Ring, Spacer	3
	701863 EPDM	701863 EPDM	701945 EPDM	701945 EPDM	O-Ring, Spacer	3
124	—	—	701271 SSL	701271 SSL	Cylinder, V-Packing	3
126	701308 SS	701308 SS	44164 SS	44164 SS	Adapter, Female	3
127	103692 STG*	103692 STG*	44607 STG*	44607 STG*	V-Packing	6
	—	—	44386 FPM	44386 FPM	V-Packing	6
128	45074 SSL	45074 SSL	44165 SS	44165 SS	Adapter, Male	3
162	43248 PTFE	43248 PTFE	43248 PTFE	43248 PTFE	Back-up-Ring, Seat	6
163	43249 NBR	43249 NBR	43249 NBR	43249 NBR	O-Ring, Seat - 80D	6
	44383 FPM	44383 FPM	44383 FPM	44383 FPM	O-Ring, Seat - 70D	6
	46206 EPDM	46206 EPDM	46206 EPDM	46206 EPDM	O-Ring, Seat - 70D	6
164	44037 SS	44037 SS	44037 SS	44037 SS	Seat	6
166	48793 SSL	48793 SSL	48793 SSL	48793 SSL	Valve	6
167	44039 SS	44039 SS	44039 SS	44039 SS	Spring, Valve	6
168	44564 PVDF	44564 PVDF	44564 PVDF	44564 PVDF	Retainer, Spring	6
179	701265 SSL	701265 SSL	701265 SSL	701265 SSL	Manifold, Valve Block, Block-Style	1
180	701078 SS	701078 SS	701078 SS	701078 SS	Plug (3/8"NPT)	3
181	89628 S	89628 S	89628 S	89628 S	Screw, HSH (M12x65)	4
185	701300 SSL	701300 SSL	701300 SSL	701300 SSL	Manifold, Discharge, Block-Style	1
187	701269 SS	701269 SS	701269 SS	701269 SS	Stud, Manifold (M10x132)	4
191	19934 SS	19934 SS	19934 SS	19934 SS	Washer, Flat (M10)	4
192	15847 S	15847 S	15847 S	15847 S	Lockwasher (M10)	4
194	81258 S	81258 S	81258 S	81258 S	Nut (M10)	4

EXPLODED VIEW

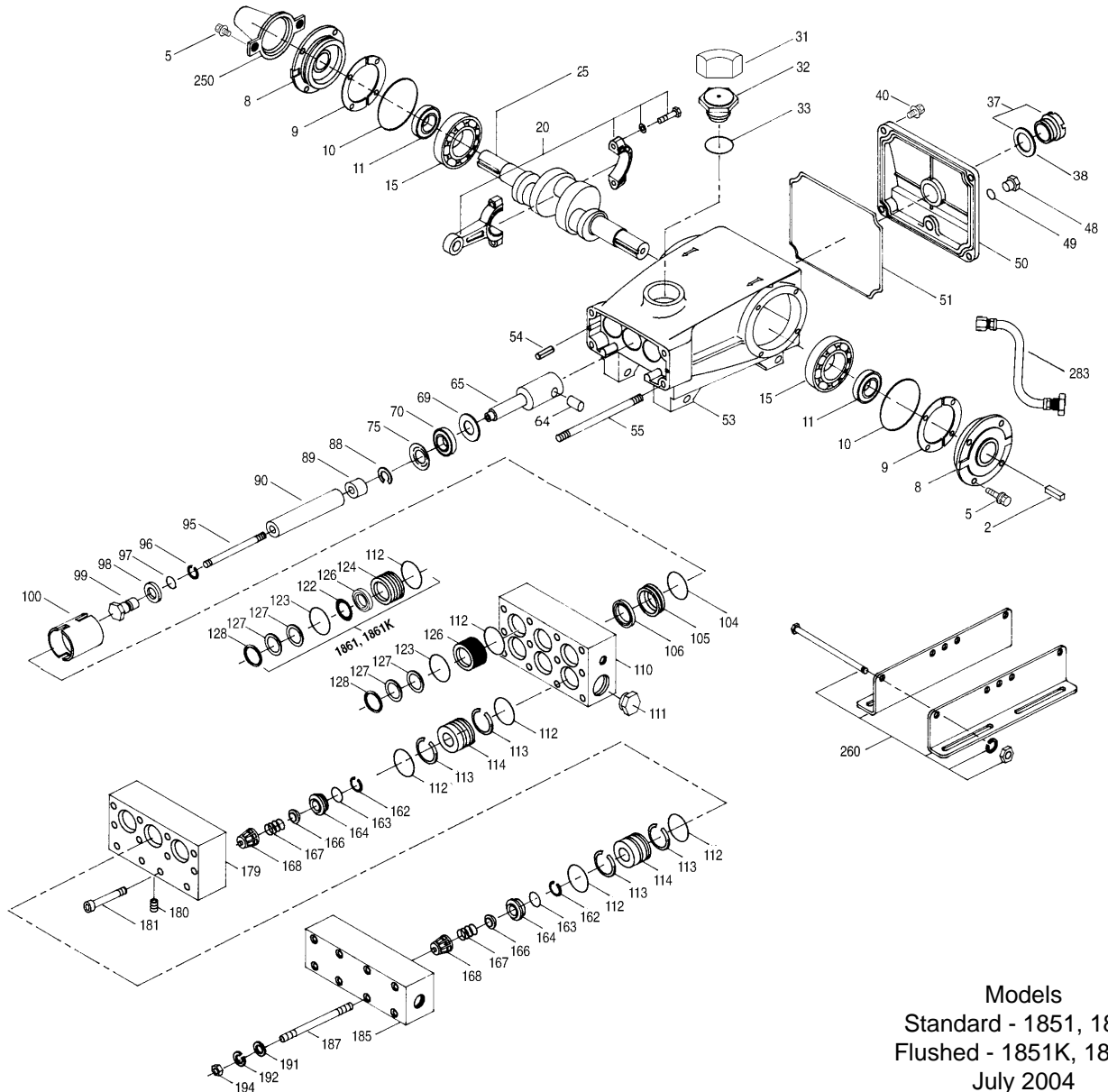

Models
 Standard - 1851, 1861
 Flushed - 1851K, 1861K
 July 2004

	1851 MATL	1851K MATL	1861 MATL	1861K MATL		
250	30764 NY	30764 NY	30764 NY	30764 NY	Protector, Shaft w/2 Screws	1
255	30264 STZP	30264 STZP	30264 STZP	30264 STZP	Mount, Direct (Incls: 12490, 12503, 14050, 81048)	1
260	30613 STZP	30613 STZP	30613 STZP	30613 STZP	Mount, Rail, Assy - A - (30635, 30903, 30921, 30912)	1
265	30661 —	30661 —	30661 —	30661 —	Kit, Complete Mounting - U.S. (30613, 30206, 30059, 30067, 30764)	1
269	30206 F	30206 F	30206 F	30206 F	Pulley, 10.0" AB [See Drive Packages, Tech Bulletin 03]	1
274	30059 STL	30059 STL	30059 STL	30059 STL	Hub, H (M30) [See Drive Packages, Tech Bulletin 03]	1
283	34334 —	34334 —	34334 —	34334 —	Kit, Oil Drain	1
290	6104 —	6104 —	6104 —	6104 —	Gasket, Liquid (1 oz.)	1
299	901310 SSL	—	901308 SSL	—	Head, Complete, Block-Style	1
	—	901311 SSL	—	901309 SSL	Head, Complete, Block-Style, Flushed	1
300	701691 NBR*	701691 NBR*	701275 NBR*	701275 NBR*	Kit, Seal (Incls: 97, 104, 106, 112, 113, 123, 127) (122 on 1861 only)	1
	701433 FPM	701433 FPM	701809 FPM	701809 FPM	Kit, Seal (Incls: 97, 104, 106, 112, 113, 123, 127) (122 on 1861 only)	1
	◆ 701805 EPDM*	◆ 701805 EPDM*	◆ 701808 EPDM*	◆ 701808 EPDM*	Kit, Seal (Incls: 97, 104, 106, 112, 113, 123, 127) (122 on 1861 only)	1
310	701695 NBR	701695 NBR	701695 NBR	701695 NBR	Kit, Valve (Incls: 112, 113, 162, 163, 164, 166, 167, 168)	2
	701434 FPM	701434 FPM	701434 FPM	701434 FPM	Kit, Valve (Incls: 112, 113, 162, 163, 164, 166, 167, 168)	2
	◆ 701804 EPDM	◆ 701804 EPDM	◆ 701804 EPDM	◆ 701804 EPDM	Kit, Valve (Incls: 112, 113, 162, 163, 164, 166, 167, 168)	2
350	30696 STZP	30696 STZP	30696 STZP	30696 STZP	Plier, Reverse	
370	—	990663 —	—	990663 —	Assembly, Flushing, 5 gal, 115V, 1.1Amp, 1/2" NPT	1
—	711500 SS	711500 SS	711500 SS	711500 SS	C.A.T. (Captive Acceleration Tube)	1
—	711504 SS	711504 SS	711504 SS	711504 SS	Adapter (2 per C.A.T.) (See Data Sheet for complete selection)	2
—	6100 —	6100 —	6100 —	6100 —	Oil, Case (12-21 oz. Bottles) ISO 68 Multi-Viscosity Hydraulic (Fill to specified crankcase capacity prior to start-up)	1

Bold print part numbers are unique to a particular pump model. Italics are optional items.

◆ Silicone oil/grease required. [] Date of latest production change. *Review material codes for individual items (STG and SFTB generally may be used as alternates).

C. A.T. highly recommended for pressurized inlet, R.O. and Industrial applications. See Tech Bulletins 002, 003, 024, 035, 036, 043, 074, 077, 083 and 089 for additional information.

MATERIAL CODES (Not Part of Part Number): ABS=ABS Plastic AL=Aluminum CC=Ceramic CM=Chrome-moly EPDM=Ethylene Propylene Diene Monomer F=Cast Iron FBR=Fiber FCM=Forged Chrome-moly FPM=Fluorocarbon (Viton®) NBR=Medium Nitrile (Buna-N) NY=Nylon POP=Polypropylene PTFE=Pure Teflon® PVDF=Fluoroplastic (High Strength) S=304SS SS=316SS SSL=316SS/Low Carbon SFTB=Special Blend (Teflon®) Black SSHS=316SS/High Strength SSZZ=316SS/Zamak STG=Special Blend (Teflon®) White STL=Steel STCP=Steel/Chrome Plated STZP=Steel/Zinc Plated TNM=Special High Strength ZZ=Zamak

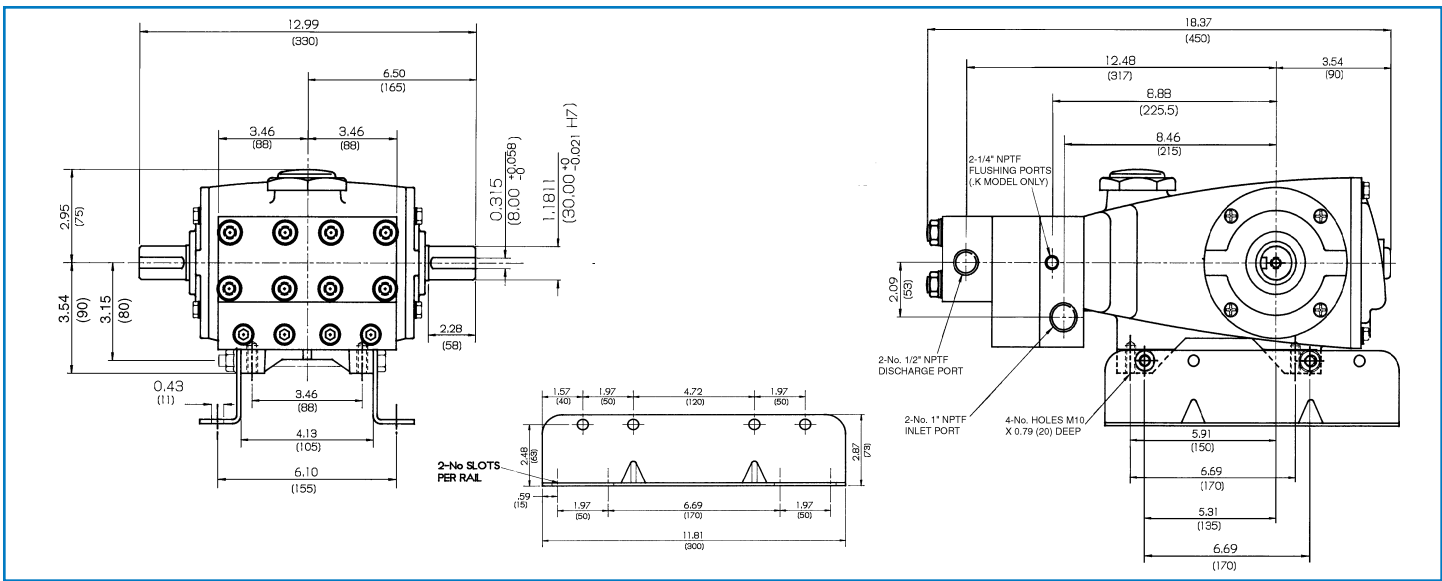

Models 1851, 1851K, 1861, 1861K

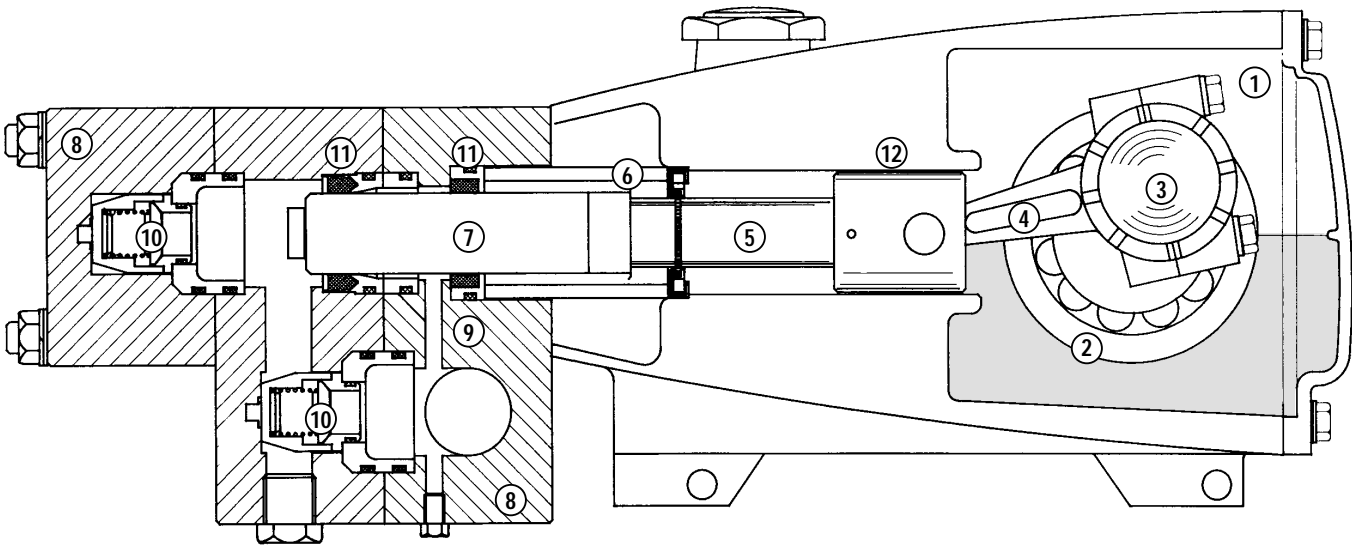

- | | | |
|---|---|---|
| <p>1 Die cast aluminum crankcase means high strength, lightweight, and excellent tolerance control.</p> <p>2 Oversized crankshaft bearings provide extended bearing life and pump performance.</p> <p>3 Chrome-moly crankshaft provides unmatched strength and surface hardness for long life.</p> <p>4 Matched oversized TNM connecting rods noted for superior tensile strength and bearing quality.</p> <p>5 Special stainless steel plunger rods with high strength crossheads for longevity and corrosion resistance.</p> | <p>6 The stainless steel slinger provides back-up protection for the crankcase seal, keeping pumped liquids out of the crankcase.</p> <p>7 Special concentric, high density, polished, graphite impregnated, solid ceramic plungers are abrasion resistant and result in extended seal life.</p> <p>8 Manifolds are 316 SSL block-style for long term continuous duty and corrosion resistance.</p> <p>9 Standard Models: Lo-Pressure Seals and V-Packings are completely lubricated and cooled by the liquid being pumped.</p> | <p>9 Flushed Models: Special ported inlet manifold permits liquid to cool or flush between V-Packings and Lo-Pressure Seals providing protection against high temperatures or contaminating pumped liquids.</p> <p>10 Stainless steel valves, seats and springs provide corrosion-resistance, ultimate seating and extended life.</p> <p>11 Specially formulated, CAT PUMP exclusive, V-Packings offer unmatched performance and seal life.</p> <p>12 Crossheads are 360° supported providing uncompromising alignment.</p> |
|---|---|---|

Products described hereon are covered by one or more of the following U.S. patents 3558244, 3652188, 3809508, 3920356, 3930756 and 5035580

World Headquarters
CAT PUMPS
 1681 - 94th Lane N.E. Minneapolis, MN 55449-4324
 Phone (763) 780-5440 — FAX (763) 780-2958
 e-mail: techsupport@catpumps.com
 www.catpumps.com



CAT PUMPS (U.K.) LTD.
 1 Fleet Business Park, Sandy Lane, Church Crookham, Fleet
 Hampshire GU52 8BF, England
 Phone Fleet 44 1252-622031 — Fax 44 1252-626655
 e-mail: sales@catpumps.co.uk

N.V. CAT PUMPS INTERNATIONAL S.A.
 Heiveldekens 6A, 2550 Kontich, Belgium
 Phone 32-3-450.71.50 — Fax 32-3-450.71.51
 e-mail: cpi@catpumps.be www.catpumps.be

CAT PUMPS DEUTSCHLAND GmbH
 Buchwiese 2, D-65510 Idstein, Germany
 Phone 49 6126-9303 0 — Fax 49 6126-9303 33
 e-mail: catpumps@t-online.de www.catpumps.de

International Inquiries
 FAX (763) 785-4329
 e-mail: intlsales@catpumps.com