

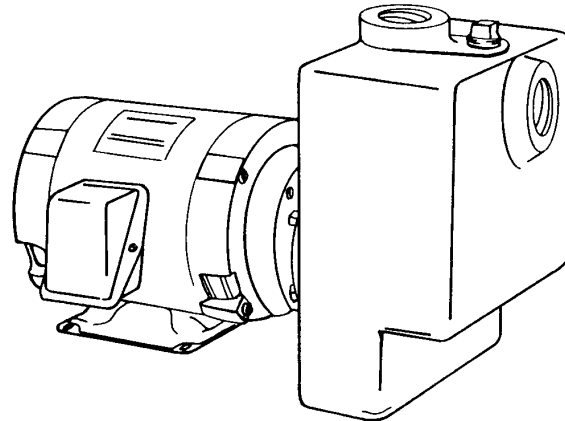

SELF-PRIMING CENTRIFUGAL PUMPS

3500RPM - 60Hz.
CAPACITIES TO 280GPM (17.7LPS)
HEADS TO 178 FEET (54.3M)



FEATURES

- CASING**
 Casing is close grain iron of 30,000 psi minimum tensile strength. Back pull-out design eliminates the need to disturb piping should the pump ever require service - the casing stays in the line.
- ENCLOSED BRONZE IMPELLER**
 Enclosed Bronze Impeller is of the latest hydraulic design for maximum efficiency. It is balanced for vibration-free operation. It is precision fit to shaft with key drive and cap screw lock.
- MECHANICAL SHAFT SEAL**
 Standard self-adjusting shaft seal for temperatures up to 225°F (107°C) and pressures to 150 psi (1034kpa). Ceramic seat and carbon seal face for long trouble-free service. Special seals are available for higher temperatures and fluids other than water.
- JM Type motors have NEMA standard mounting flange, extended steel shaft and dual bearings. These motors offer the advantage of quiet operation, controlled shaft deflection for longer seal life, and bearings sized to provide good service life. All motors are supplied by manufactures with national field service facilities.
- Flapper and check valves on the suction pipe are not required, but are recommended.
- BRONZE SHAFT SLEEVE**
 Gasketed and keyed hook-type sleeve protects shaft from wear and corrosion in seal area.

- FACTORY TESTED**
 After careful assembly and inspection, **EVERY** pump is factory tested and will meet Hydraulic Institute standards.

MAXIMUM OPERATING CONDITIONS	
TEMPERATURE (For Standard Buna-N Seal)	225°F (107°C)
INLET PRESSURE	100 PSI (690kpa)
CASING WORKING PRESSURE	200 PSI (1379kpa)

- MOTOR INFORMATION**
 60 Hz - 3500 RPM - ODP
Three Phase: 5, 7-1/2 & 10 Hp. - 230/460 Volt
 Voltages may differ from some suppliers. Consult factory.
Overload Protection: All motors must be installed with a magnetic starter which provides full 3-leg protection. Failure to use correct starter and overloads will void motor warranty.

MATERIALS OF CONSTRUCTION		
PART	ALL IRON	BRONZE FITTED
Adapter	Cast Iron	Cast Iron
Casing	Cast Iron	Cast Iron
Casing Wear Ring	Steel	Bronze
Shaft	#316 Stainless	#316 Stainless
Impeller	Cast Iron	Bronze
Shaft Seal	Carbon-Ceramic S. Steel-Buna-N	Carbon-Ceramic S. Steel-Buna-N

SECTION	4A
PAGE	2
ISSUED	6/03
REPLACES	2/03



420 Third Street
Piqua, Ohio 45356-0603
Phone: (937) 778-8947 Fax: (937) 773-7157

END SUCTION CENTRIFUGAL PUMPS

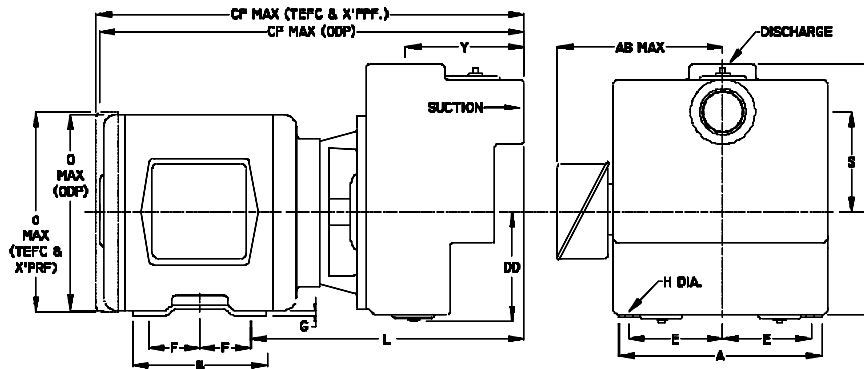
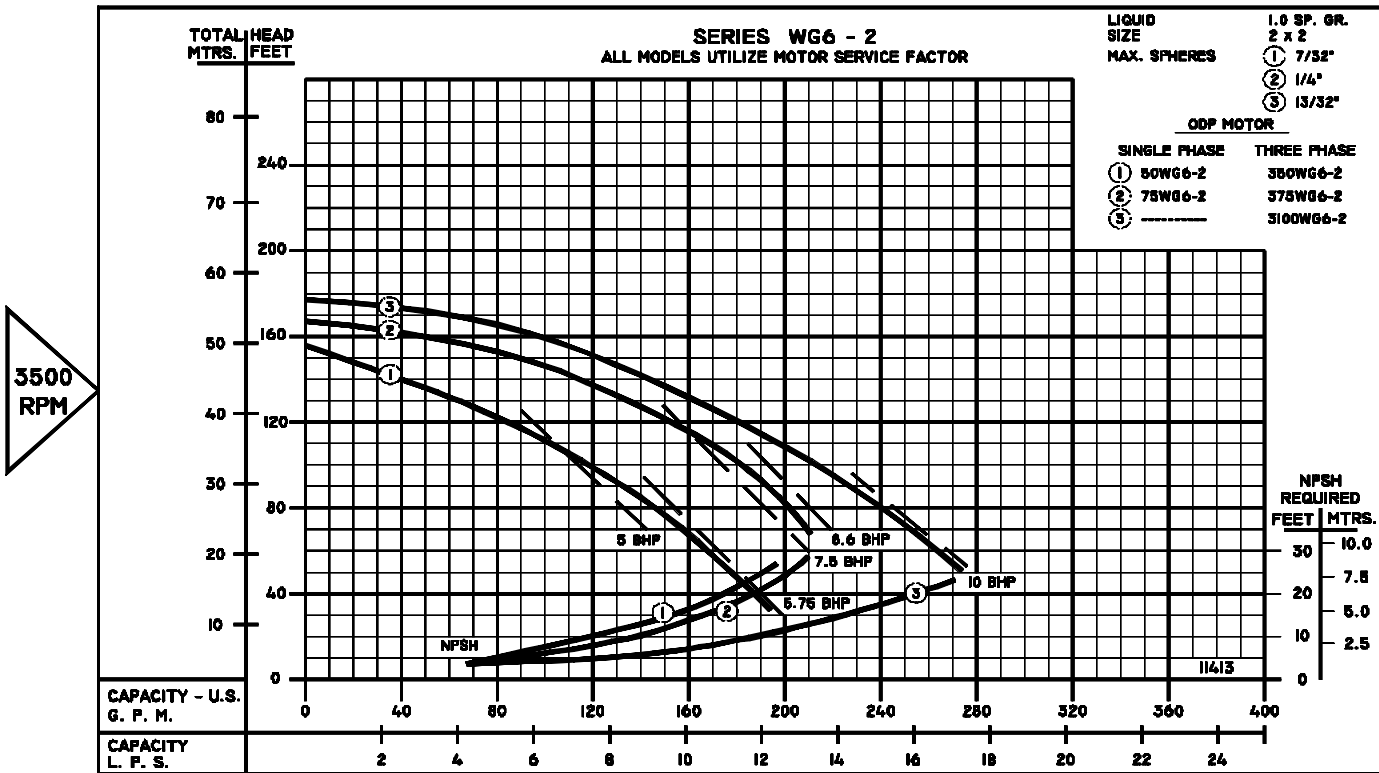

MODEL 3 PHASE	HP	Motor Frame Size	DISC. NPT	SUCT. NPT	DIMENSIONS IN INCHES														
					A	AB	B	CP	D	DD	E	F	G	H	L	O	S	X	Y
350WG6-2	5	182JM	2	2	8 ³ / ₄	9 ¹¹ / ₁₆	5 ³ / ₄	21 ¹¹ / ₁₆	4 ¹ / ₂	6 ¹ / ₂	3 ³ / ₄	2 ¹ / ₄	1 ¹ / ₂	13 ¹³ / ₃₂	14	9 ¹¹ / ₁₆	6 ⁵ / ₁₆	9	6 ¹ / ₁₆
375WG6-2	7 ¹ / ₂	184JM	2	2	8 ³ / ₄	9 ¹¹ / ₁₆	6 ³ / ₄	23 ¹¹ / ₁₆	4 ¹ / ₂	6 ¹ / ₂	3 ³ / ₄	2 ³ / ₄	1 ¹ / ₂	13 ¹³ / ₃₂	14	9 ¹¹ / ₁₆	6 ⁵ / ₁₆	9	6 ¹ / ₁₆
3100WG6-2	10	213JM	2	2	10 ³ / ₈	10 ⁷ / ₈	7 ³ / ₄	24 ³ / ₁₆	5 ¹ / ₄	6 ¹ / ₂	4 ¹ / ₄	2 ³ / ₄	5 ⁵ / ₈	13 ¹³ / ₃₂	14 ⁷ / ₈	11	6 ⁵ / ₁₆	9	6 ¹ / ₁₆

MODEL 3 PHASE	HP	Motor Frame Size	DISC. NPT inch	SUCT. NPT inch	DIMENSIONS IN MILLIMETERS														
					A	AB	B	CP	D	DD	E	F	G	H	L	O	S	X	Y
350WG6-2	5	182JM	2	2	222	246	146	551	114	165	95	57	13	10	356	246	160	229	154
375WG6-2	7 ¹ / ₂	184JM	2	2	222	246	171	602	114	165	95	70	13	10	356	246	160	229	154
3100WG6-2	10	213JM	2	2	264	276	197	614	133	165	108	70	16	10	378	279	160	229	154

Dimensions shown above are approximate maximum dimensions for standard pumps equipped with open drip-proof motors.

DO NOT USE FOR CONSTRUCTION PURPOSES. CERTIFIED DRAWINGS AVAILABLE ON REQUEST.



PUMPS & SYSTEMS

A Crane Co. Company