

## Self-Priming Centrifugal Pumps

### APPLICATIONS

- Lawn Sprinkling
- Pressure Boosting
- Sprinkler Systems
- Light Irrigation
- Dewatering clean liquids
- Transfer from underground storage

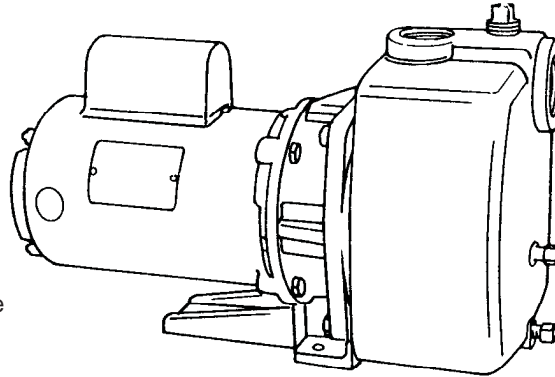

- Fast Priming pumps stays primed. Flapper and check valves on suction pipe are not required, but are recommended.
- Non-overloading performance at all catalog ratings.
- Continuous duty motors.
- Leak Proof mechanical shaft seal - self adjusting
- Cast Iron Casing with suction, discharge, prime, vacuum gauge and drain tapings.
- All Bronze or All Iron construction available.
- Glass filled Noryl® enclosed impeller with molded-in brass insert.
- Every pump is factory tested and will meet Hydraulic Institute standards

### MOTOR INFORMATION

60 Hz - 3500 RPM - ODP

Single Phase: 1 thru 2 Hp - 115/230 Volts; 3 Hp. - 230 Volt

Three Phase: 1 thru 3 Hp. - 208-230/460 Volt

Voltages may differ from some suppliers. Consult factory.

**Overload Protection:** All single phase ODP and TEFC motors must have built-in overload protection. All three phase motors and all explosion proof motors must be installed with a magnetic starter which provides full 3-leg protection. Failure to use correct starter and overloads will void motor warranty.

### MATERIALS OF CONSTRUCTION

PART	STANDARD	ALL IRON	ALL BRONZE
Adapter	Cast Iron	Cast Iron	Bronze
Case	Cast Iron	Cast Iron	Bronze
Diffuser	Cast Iron	Cast Iron	Bronze
Impeller	Noryl®	Cast Iron	Bronze
Shaft	#303 Stainless	#303 Stainless	#303 Stainless
Shaft Seal	Carbon-Ceramic SS - Buna-N	Carbon-Ceramic SS - Buna-N	Carbon-Ceramic SS - Buna-N

### MAXIMUM OPERATING CONDITIONS

TEMPERATURE (For Standard Noryl Impeller)	175°F (80°C)
INLET PRESSURE	100 PSI (689kPa)
CASING WORKING PRESSURE	200 PSI (1379kPa)

### 60 HZ - PERFORMANCE AND SELECTION FOR SUCTION LIFT - 3500 RPM

Catalog No.	HP	Suction & Discharge	Discharge Pressure Pounds	Capacity GPM (LPS) At Suction Lift and Discharge Pressure Shown					
				0' Suction	5' (1.5m) Suction	10" (3m) Suction	15' (4.5m) Suction	20' (6.1m) Suction	25' (7.6m) Suction
10WA6	1	1½	20 (137kpa)	52 (3.3)	51 (3.2)	48 (3.0)	46 (2.9)	43 (2.7)	36 (2.2)
			30 (206kpa)	43 (2.7)	39 (2.4)	36 (2.2)	33 (2.0)	30 (1.8)	25 (1.5)
			40 (275kpa)	23 (1.4)	20 (1.2)	14 (0.8)	5 (0.3)	---	---
15WA6	1½	1½	20 (137kpa)	61 (3.8)	61 (3.8)	56 (3.5)	53 (3.3)	49 (3.0)	41 (2.5)
			30 (206kpa)	58 (3.6)	58 (3.6)	54 (3.4)	51 (3.2)	47 (2.9)	40 (2.5)
			40 (275kpa)	47 (2.9)	43 (2.7)	38 (2.3)	35 (2.2)	30 (1.8)	---
			50 (344kpa)	24 (1.5)	19 (1.1)	9 (0.5)	---	---	---
20WA6	2	1½	20 (137kpa)	73 (4.6)	69 (4.3)	67 (4.2)	63 (3.9)	58 (3.6)	50 (3.1)
			30 (206kpa)	68 (4.2)	67 (4.2)	64 (4.0)	61 (3.8)	56 (3.5)	48 (3.0)
			40 (275kpa)	58 (3.6)	54 (3.4)	50 (3.1)	46 (2.9)	41 (2.5)	34 (2.1)
			50 (344kpa)	37 (2.3)	31 (1.9)	23 (1.4)	---	---	---
30WA6	3	1½	20 (137kpa)	93 (5.8)	93 (5.8)	93 (5.8)	92 (5.8)	82 (5.1)	66 (4.1)
			30 (206kpa)	85 (5.3)	83 (5.2)	83 (5.2)	80 (5.0)	76 (4.7)	64 (4.0)
			40 (275kpa)	72 (4.5)	68 (4.2)	64 (4.0)	59 (3.7)	55 (3.4)	46 (2.9)
			50 (344kpa)	50 (3.1)	43 (2.7)	35 (2.2)	22 (1.3)	---	---

**Self-Priming Centrifugal Pumps**

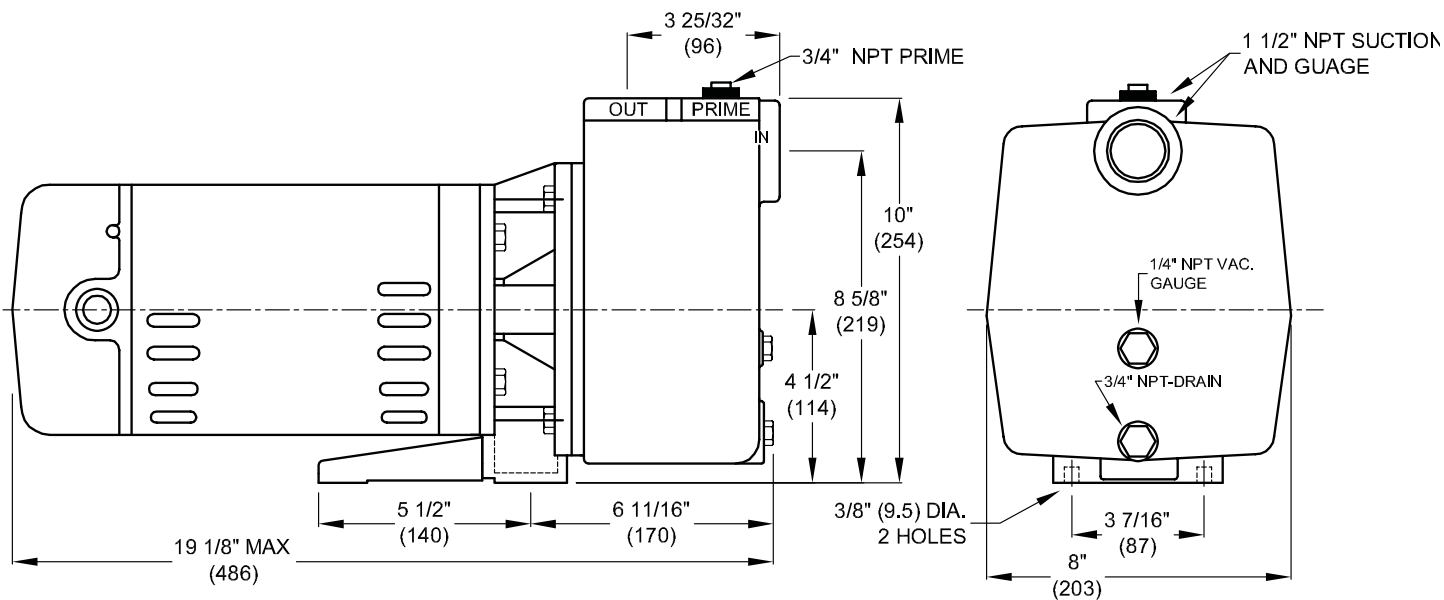
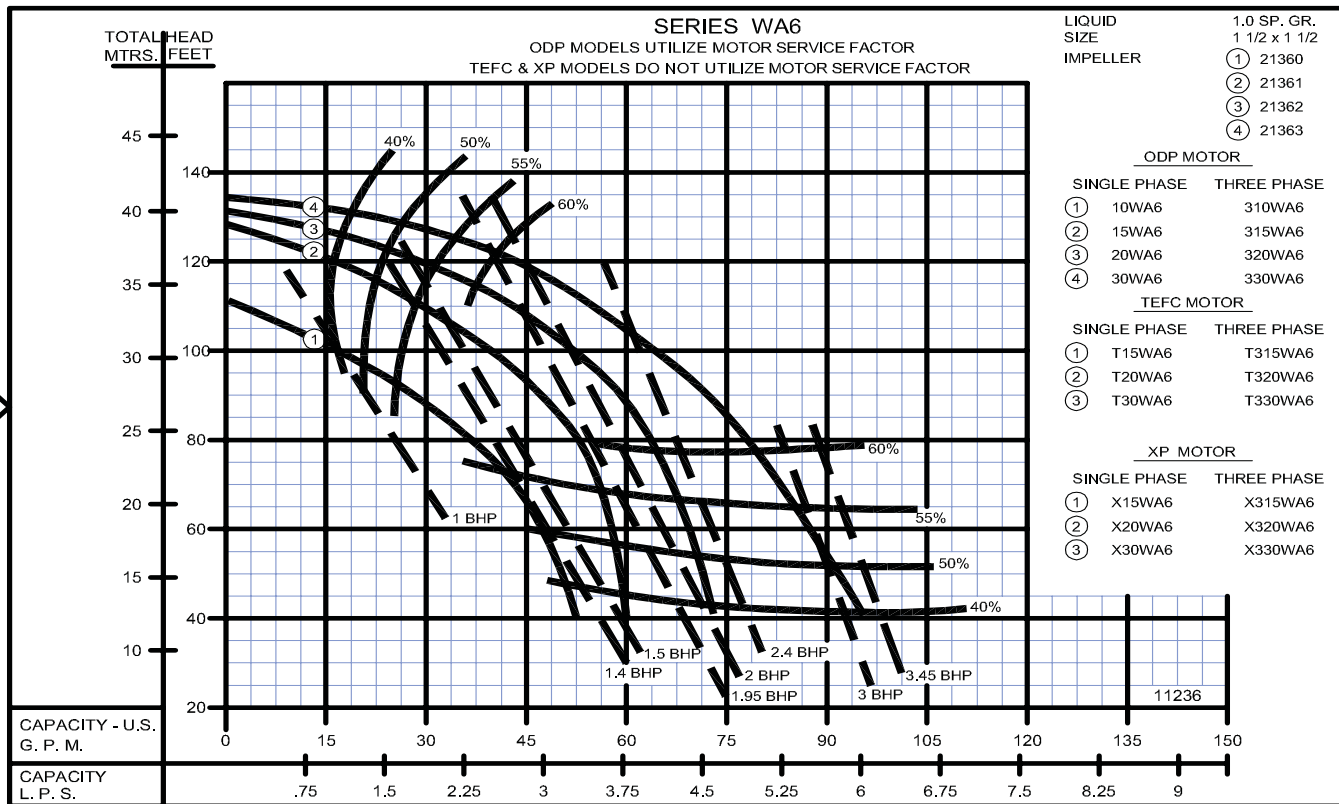

DO NOT USE FOR CONSTRUCTION PURPOSES. CERTIFIED DRAWINGS AVAILABLE ON REQUEST

SECTION 4B  
PAGE 2  
DATE 1/06



**PUMPS & SYSTEMS**