

PROSSER®

INSTALLATION MANUAL Portable Submersible Pump

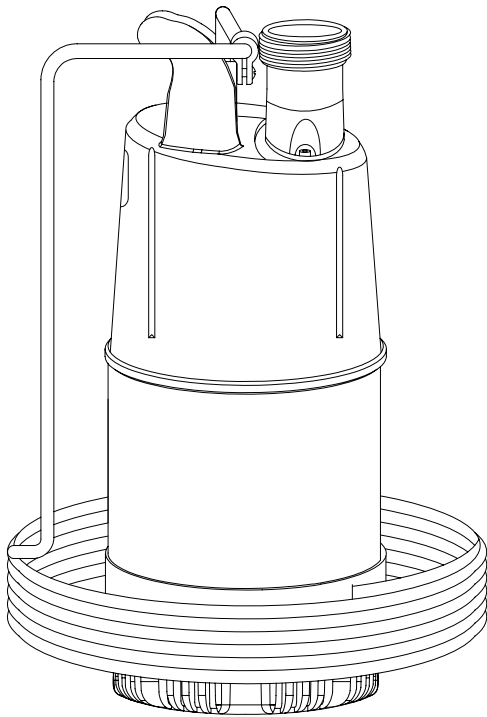

126 Series
1.25 HP, 220 Volt, 50Hz

IMPORTANT!

***Read all instructions in this manual before operating pump.
As a result of Crane Pumps & Systems, Inc., constant product improvement program,
product changes may occur. As such Crane Pumps & Systems reserves the right to
change product without prior written notification.***

CRANE

A Crane Co. Company

PUMPS & SYSTEMS

420 Third Street
Piqua, Ohio 45356
Phone: (937) 778-8947
Fax: (937) 773-7157
www.cranepumps.com

83 West Drive, Bramton
Ontario, Canada L6T 2J6
Phone: (905) 457-6223
Fax: (905) 457-2650



Form No. 115150-50-Rev. D

SAFETY FIRST!

Please Read This Before Installing Or Operating Pump. This information is provided for **SAFETY** and to **PREVENT EQUIPMENT PROBLEMS**. To help recognize this information, observe the following symbols:



IMPORTANT! Warns about hazards that can result in personal injury or indicates factors concerned with assembly, installation, operation, or maintenance which could result in damage to the machine or equipment if ignored.

CAUTION! Warns about hazards that **can or will cause minor** personal injury or property damage if ignored. Used with symbols below.

WARNING! Warns about hazards that can or will cause serious personal injury, death, or major property damage if ignored. Used with symbols below.



Hazardous fluids can cause fire or explosions, burns or death could result.



Extremely hot - Severe burns can occur on contact.



Biohazard can cause serious personal injury.



Hazardous fluids can cause hazardous pressure, eruptions or explosions could cause personal injury or property damage.



Rotating machinery Amputation or severe laceration can result.



Hazardous voltage can shock, burn or cause death.

Only qualified personnel should install, operate and repair pump. Any wiring of pumps should be performed by a qualified electrician.

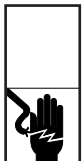

WARNING ! To reduce risk of electrical shock, pumps and control panels must be properly grounded in accordance with the National Electric Code (NEC) or the Canadian Electrical Code (CEC) and all applicable state, province, local codes and ordinances. Improper grounding voids warranty.



WARNING! To reduce risk of electrical shock, always disconnect the pump from the power source before handling or servicing. Lock out power and tag.



WARNING! Operation against a closed discharge valve will cause premature bearing and seal failure on any pump, and on end suction and self priming pump the heat build may cause the generation of steam with resulting dangerous pressures. It is recommended that a high case temperature switch or pressure relief valve be installed on the pump body.



CAUTION ! Never operate a pump with a plug-in type power cord without a ground fault circuit interrupter.



CAUTION ! Pumps build up heat and pressure during operation-allow time for pumps to cool before handling or servicing.



WARNING ! Do not pump hazardous materials (flammable, caustic, etc.) unless the pump is specifically designed and designated to handle them.



CAUTION ! Do not block or restrict discharge hose, as discharge hose may whip under pressure.



WARNING ! Do not wear loose clothing that may become entangled in moving parts.



WARNING ! Keep clear of suction and discharge openings. **DO NOT** insert fingers in pump with power connected.



Always wear eye protection when working on pumps.



Make sure lifting handles are securely fastened each time before lifting. **DO NOT** operate pump without safety devices in place. Always replace safety devices that have been removed during service or repair. Secure the pump in its operating position so it can not tip over, fall or slide.



DO NOT exceed manufacturers recommendation for maximum performance, as this could cause the motor to overheat.

DO NOT remove cord and strain relief. **DO NOT** connect conduit to pump.



WARNING ! Cable should be protected at all times to avoid punctures, cut, bruises and abrasions. Inspect frequently. Never handle connected power cords with wet hands.



WARNING ! To reduce risk of electrical shock, all wiring and junction connections should be made per the NEC or CEC and applicable state or province and local codes. Requirements may vary depending on usage and location.



WARNING! Submersible Pumps are not approved for use in swimming pools, recreational water installations decorative fountains or any installation where human contact with the pumped fluid is common.



WARNING! Products returned must be cleaned, sanitized, or decontaminated as necessary prior to shipment, to insure that employees will not be exposed to health hazards in handling said material. All Applicable Laws And Regulations Shall Apply.



Bronze/brass and bronze/brass fitted pumps may contain lead levels higher than considered safe for potable water systems. Lead is known to cause cancer and birth defects or other reproductive harm. Various government agencies have determined that leaded copper alloys should not be used in potable water applications. For non-leaded copper alloy materials of construction, please contact factory.



Crane Pumps & Systems, Inc. is not responsible for losses, injury, or death resulting from a failure to observe these safety precautions, misuse or abuse of pumps or equipment.

Other brand and product names are trademarks or registered trademarks of their respective holders.

© Prosser is a registered trademarks of Crane Pumps & Systems, Inc.

11/2004, 5/06, 9/06

Alteration Rights Reserved

PUMP SPECIFICATIONS:

DISCHARGE 2" NPT (M), Vertical
LIQUID TEMPERATURE 104°F (40°C) Max.
VOLUTE Non-Metallic
MOTOR SHELL Stainless Steel
IMPELLER Non-Metallic
SHAFT 420 Stainless Steel
HARDWARE 300 Series Stainless Steel
SEAL *Design* Tandem Mechanical, Oil-Filled Reservoir

Material:

Rotating Face . Silicon/Carbide, Pump End
 Carbon, Motor End
Stationary Face Silicon/Carbide
Elastomer Buna-N
Hardware 300 series stainless steel

CORD ENTRY 50 Ft. (15m) Cord Molded for strain relief and compression seal
SPEED 2850 RPM (Nominal)
MOTOR: *Design* NEMA Design C - Single Phase, Air-Filled, Squirrel Cage Induction
 Class F
SINGLE PHASE Capacitor Start and Run
 Includes Overload protection in motor
LIFTING ROPE 3/8" (9.7mm) Polypropylene, 25 Ft (7.6m)
STRAINER25" (6mm) Openings, Non-Metallic
LIFTING HANDLE Non-Metallic

MODEL NO.	PART NO.	A - Dim Inch (mm)	HP	VOLT	PH	HERTZ	RPM	FULL LOAD AMPS
126-50	115168A	18.54 (471)	1.25	220	1	50	2850	7.6

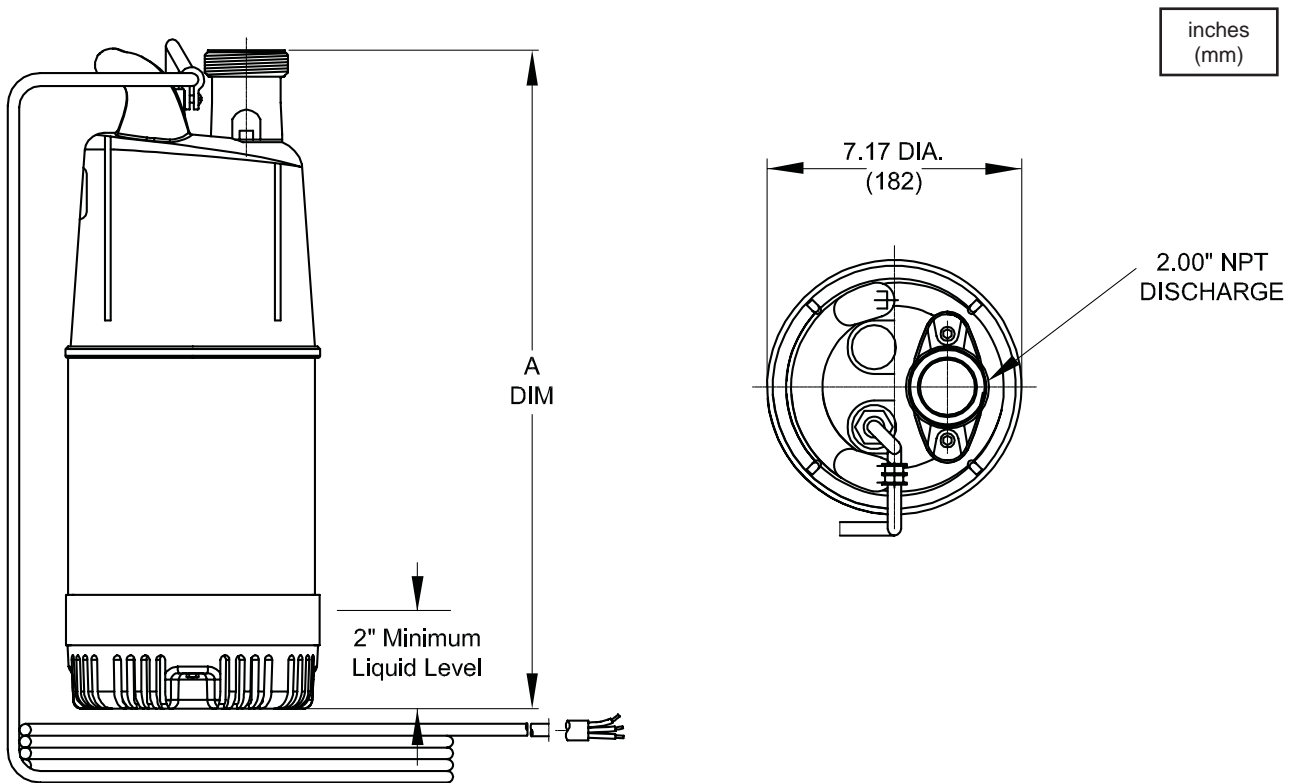

IMPORTANT !

- 1.) PUMP MAY BE OPERATED "DRY" FOR EXTENDED PERIODS WITHOUT DAMAGE TO MOTOR AND/OR SEALS.
- 2.) THIS PUMP IS APPROPRIATE FOR THOSE APPLICATIONS SPECIFIED AS CLASS I DIVISION II HAZARDOUS LOCATIONS.
- 3.) THIS PUMP IS **NOT** APPROPRIATE FOR THOSE APPLICATIONS SPECIFIED AS CLASS I DIVISION I HAZARDOUS LOCATIONS.
- 4.) INSTALLATIONS SUCH AS DECORATIVE FOUNTAINS OR WATER FEATURES PROVIDED FOR VISUAL ENJOYMENT MUST BE INSTALLED IN ACCORDANCE WITH THE NATIONAL ELECTRIC CODE ANSI/NFPA 70 AND/OR THE AUTHORITY HAVING JURISDICTION. THIS PUMP IS NOT INTENDED FOR USE IN SWIMMING POOLS, RECREATIONAL WATER PARKS, OR INSTALLATIONS IN WHICH HUMAN CONTACT WITH PUMPED MEDIA IS A COMMON OCCURRENCE.

SECTION B: GENERAL INFORMATION

B-1) To the Purchaser:

Congratulations! You are the owner of one of the finest pumps on the market today. CP&S pumps are products engineered and manufactured of high quality components. Over one hundred years of pump building experience along with a continuing quality assurance program combine to produce a pump which will stand up to the toughest applications.

This manual will provide helpful information concerning installation, maintenance, and proper service guidelines.

B-2) Receiving:

Upon receiving the pump, it should be inspected for damage or shortages. If damage has occurred, file a claim immediately with the company that delivered the pump. If the manual is removed from the packaging, do not lose or misplace.

B-3) Storage:

Short Term- CP&S Pumps are manufactured for efficient performance following short inoperative periods in storage. For best results, pumps can be retained in storage, as factory assembled, in a dry atmosphere with constant temperatures for up to six (6) months.

Long Term- Any length of time exceeding six (6) months, but not more than twenty-four (24) months. The unit should be stored in a temperature controlled area, a roofed over walled enclosure that provides protection from the elements (rain, snow, wind-blown dust, etc.), and whose temperature can be maintained between +40 deg. F and +120 deg. F. (4.4 - 49°C).

Pump should be stored in its original shipping container. On initial start up, rotate impeller by hand to assure seal and impeller rotate freely. If it is required that the pump be installed and tested before the long term storage begins, such installation will be allowed provided:

- 1.) The pump is not installed under water for more than one (1) month.
- 2.) Immediately upon satisfactory completion of the test, the pump is removed, thoroughly dried, repacked in the original shipping container, and placed in a temperature controlled storage area.

B-4) Service Centers:

For the location of the nearest Barnes Center, check your Barnes representative or Crane Pumps & Systems, Inc., Service Department in Piqua, Ohio, telephone (937) 778-8947 or Crane Pumps & Systems Canada, in Brampton, Ontario, (905) 457-6223.

SECTION C: INSTALLATION

C-1) Location:

These pumps are recommended for general and light construction, for sump and dewatering drainage, for dewatering manholes and transformer vaults, for pit, tunnel and trench dewatering, and for flood, fire and other emergency service cleanup.

Before pumping fluids other than water, consult the factory, giving fluid, fluid temperature, specific gravity, viscosity, capacity in USGPM and total head and/or pressure requirements, including friction loss through discharge line, fittings, valves, etc. Pump may run dry for 5 to 10 minutes in air without damage where air can circulate freely through the pump. **DO NOT** allow pump to be buried in mud or sand.

C-2) Discharge:

Discharge hose is recommended. If rigid pipe is used, install so that there is no weight or strain on the pump.

C-3) Liquid Level Controls: (If Applicable)

Attach "ON" float to discharge hose or pump cable at desired pump "ON" level. Attach "OFF" float to discharge hose or pump cable at desired pump "OFF" level. The "OFF" float must be below the "ON" float. To attach the floats, thread the cable strap through the buckle with the ratchet pawl, cinch up tight, thread excess strapping through outer buckle slot. Be certain the level controls cannot hang up or foul in its swing. It is recommended that the pump is completely submerged when the level control is in the "OFF" mode.

C-4.1) Electrical Connections:

The pump comes with a three wire cord without a plug on the 220 volt models.

If a plug is to be used, an appropriate 220 volt plug that matches your receptacle will be required. Make sure the plug meets the pump amp requirements found on the nameplate. Follow the plug manufacturer's wiring installation instructions.

DO NOT USE THE POWER CABLE TO LIFT PUMP.

C-4.2) Overload Protection:

An automatic thermal overload protects the motor. The type of in-winding overload protector used is referred to as an inherent overheating protector and operates on the combined effect of temperature and current. This means that the overload protector will trip out and shut the pump off if the windings become too hot or the current passing through them becomes too high.

It will then automatically reset and restart the pump after the motor cools to a safe temperature. In the event of an overload, the source of this condition should be determined and rectified immediately. **DO NOT LET THE PUMP CYCLE OR RUN IF AN OVERLOAD CONDITION OCCURS!**

SECTION D - START UP OPERATION

D-1) Check Pump Rotation:

Before putting pump into service for the first time, the motor rotation must be checked. This is especially true on 220 volt pumps after installing the appropriate cable plug (if used). Improper motor rotation can result in poor pump performance and can damage the motor and/or pump. To check the rotation, suspend the pump freely, momentarily apply power and observe the "kick". "Kick" should always be in a counterclockwise direction as viewed from the top of the pump motor housing. Pump "kick" is the opposite direction of pump rotation.

D-2) Start Up:

DO NOT attempt to start a frozen pump.

Instead, submerge pump in water for twenty minutes before starting. DO NOT attempt to thaw a frozen pump with a torch.



D-3) Warranty Registration:

Fill in the Warranty Registration at the end of this manual and send it in to our Warranty / Service Department. Also, record the model number and date code numbers in Section F-1 of this manual for future reference if needed.

SECTION E - PREVENTATIVE MAINTENANCE

The following procedure must be followed to assure proper pump operation.

E-1) General Safety:

Frequent inspections shall be made. All electrical parts, including the portable cable and wiring shall be kept in a safe condition. **KEEP CABLE GLAND NUT TIGHT. CHECK FREQUENTLY.** There shall be no openings in the casing of the electrical parts. The operating voltage shall match the voltage rating of the motor.

E-2) Servicing:

Pump shall be restored to the state of original safety with respect to all lead entrances, etc. following disassembly.

E-3) Renewals and Repairs:

Special care shall be taken in making renewals and repairs. Leave no parts off. Use replacement parts furnished by the manufacturer. When any lead entrance is disturbed, the original leads or exact duplicates thereof shall be used.

E-4) Fasteners:

All bolts, nuts, screws and other means of fastenings shall be in place, properly tightened and secured.

E-5) Cable Requirements:

Special care shall be taken in handling the cable (7) against mechanical injury and wear. Connections and wiring to the power source shall be in accordance with all electrical and safety codes.

E-6) Shaft Seals:

The seals (12 & 16) should be inspected every 400 or 500 operating hours for wear (more often if abrasives are present). To make a quick check of the seal's condition, drain and inspect the oil in the seal chamber (see Section F1.1). If oil removed from the pump contains water or abrasives, replace the seals.

SECTION F - SERVICE AND REPAIR

F-1) Lubrication:

F-1.1) Checking Oil - To check the seal chamber oil, invert the pump and remove the screws (26) lockwashers (11) strainer (25), suction case (24), impeller nut (15), washers (14 & 22) and Impeller (21). Remove the socket head screw (9) with o-ring (8) from the hole marked "OIL". With a flashlight, visually inspect the oil in the seal cavity to make sure it is clean and clear, light amber in color and free from suspended particles. Milky white oil indicates the presence of water. If the oil looks milky white, pour the oil out of the oil chamber and let it settle in a clean dry container. If any water settles out in the bottom of the container or if the oil is white and thick (emulsified), replace the mechanical seals and oil.

You can also check oil for contamination by using an oil tester with a range to 30 Kilovolts breakdown. If oil is found to be clean and uncontaminated (measure at or above 15KV. Breakdown), refill the seal cavity. If the oil is found to be dirty, or contaminated (or measures below 15KV. Breakdown), replace the mechanical seals and oil.

F-1.2) Replacing Oil:

Follow steps in E-2.1 to remove socket head screw (9) with o-ring (8) from the hole marked "OIL". Turn pump over to drain oil from seal chamber. Dispose oil properly. Flush inside seal chamber of diffuser thoroughly to be sure it is clean and free of abrasives. Refill seal chamber with 3 oz. (90 ml) of an approved oil. The oil shall be of a highly refined paraffinic base, straight mineral oil, free of all additives (called non-inhibited or non-detergent). Refer to Table 1 for recommendations.

TABLE 1 - COOLING OIL - Dielectric

SUPPLIER	GRADE
Shell	Turbo oil 32
Texaco	Rando HD32
Mobile	D.T.E. Oil Light
G & G Oil	Circulating 22

F-1.3) Seal Cavity Pressure Test:

Remove the socket head screw (9) and o-ring (8) from the hole marked "OIL" and check for correct amount of oil. Apply pipe sealant to pressure gauge assembly and tighten into hole (See Figure 1). Pressure seal chamber to 12 PSI and check for leaks. If after five minutes, the pressure is still holding constant, and no leaks are observed, slowly bleed the pressure and remove the gauge assembly. Replace socket head screw (9) with o-ring (8) using a sealant. If the pressure does not hold, then the leak must be located and repaired.

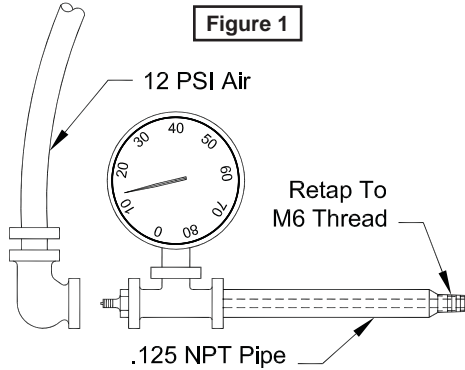

F-2) Impeller Replacement:

Please refer to instructions included with the Repair Parts Kit.

F-3) Mechanical Seal Replacement:

Please refer to instructions included with the Repair Parts Kit.

F-4) Power Supply Cord Replacement:

Please refer to instructions included with the Repair Parts Kit.

F-5) Discharge Nozzle Replacement:

Please refer to instructions included with the Repair Parts Kit.

F-6) Strainer Replacement:

Please refer to instructions included with the Repair Parts Kit.

SECTION G - WARRANTY REPAIR AND REPLACEMENT PARTS

G-1) Information Needed:

Always furnish the following information:

1. Pump Part Number _____
2. Pump Model Number _____
3. Pump Date Code _____

NOTE: Record your pump information here for future reference.

PORTABLE SUBMERSIBLE PUMP

PROSSER® CRANE® PUMPS & SYSTEMS
Piqua, Ohio

MODEL 126-50 1.25HP 7.6 FULL LOAD AMPS 220 VOLT

2850RPM 50HZ 1PH 40°C MAX AMB. TEMP. INS. CLASS: F
Made in China

(04) (05) (06) (07) (08) (09)

(1) (2) (3) (4) (5) (6) (7) (8) (9) (10) (11) (12)

112888B

G-2) Part Number:

The Part Number consists of a six (6) digit number, which appears in the catalog and page 3 of this manual. This number is used for ordering and obtaining information.

G-3) Model Number:

This designation consists of numbers and letters which represents the horsepower, motor phase, voltage and pump design.

G-4) Date Code:

The Date Code consists of two numbers that are punched holes in the nameplate. This specifies the month and year indicating the date the unit was built.

TROUBLE SHOOTING

CAUTION ! Always disconnect the pump from the electrical power source before handling.

If the system fails to operate properly, carefully read instructions and perform maintenance recommendations.

If operating problems persist, the following chart may be of assistance in identifying and correcting them:

MATCH "CAUSE" NUMBER WITH CORRELATING "CORRECTION" NUMBER.

NOTE: Not all problems and corrections will apply to each pump model.

PROBLEM	CAUSE	CORRECTION
Pump will not run	<ol style="list-style-type: none"> 1. Poor electrical connection, blown fuse, tripped breaker or other interruption of power, improper power supply. 2. Motor or switch inoperative (to isolate cause, go to manual operation of pump). <ol style="list-style-type: none"> 2a. Float movement restricted. 2b. Switch will not activate pump or is defective. 3. Insufficient liquid level. 	<ol style="list-style-type: none"> 1. Check all electrical connections for security. Have electrician measure current in motor leads, if current is within $\pm 20\%$ of locked rotor Amps, impeller is probably locked. If current is 0, overload may be tripped. Remove power, allow pump to cool, then recheck current. 2a. Reposition pump or clean basin as required to provide adequate clearance for float.
Pump will not turn off	<ol style="list-style-type: none"> 2a. Float movement restricted. 2b. Switch will not activate pump or is defective. 4. Excessive inflow or pump not properly sized for application. 9. Pump may be airlocked. 14. H-O-A switch on panel is in "HAND" position 	<ol style="list-style-type: none"> 2b. Disconnect level control. Set ohmmeter for a low range, such as 100 ohms full scale and connect to level control leads. Actuate level control manually and check to see that ohmmeter shows zero ohms for closed switch and full scale for open switch. (Float Switch). 2c. Check winding insulation (Megger Test) and winding resistance. If check is outside of range, dry and recheck. If still defective, replace per service instructions.
Pump hums but does not run	<ol style="list-style-type: none"> 1. Incorrect voltage 8. Impeller jammed or loose on shaft, worn or damaged, impeller cavity or inlet plugged. 	<ol style="list-style-type: none"> 3. Make sure liquid level is at least equal to suggested turn-on point.
Pump delivers insufficient capacity	<ol style="list-style-type: none"> 1. Incorrect voltage. 4. Excessive inflow or pump not properly sized for application. 5. Discharge restricted. 6. Check valve stuck closed or installed backwards. 7. Shut-off valve closed. 8. Impeller jammed or loose on shaft, worn or damaged, impeller cavity or inlet plugged. 9. Pump may be airlocked. 10. Pump stator damaged/torn. 	<ol style="list-style-type: none"> 4. Recheck all sizing calculations to determine proper pump size. 5. Check discharge line for restrictions, including ice if line passes through or into cold areas. 6. Remove and examine check valve for proper installation and freedom of operation. 7. Open valve. 8. Check cutter for freedom of operation, security and condition. Clean cutter and inlet of any obstruction.
Pump cycles too frequently or runs periodically when fixtures are not in use	<ol style="list-style-type: none"> 6. Check valve stuck closed or installed backwards. 11. Fixtures are leaking. 15. Ground water entering basin. 	<ol style="list-style-type: none"> 9. Loosen union slightly to allow trapped air to escape. Verify that turn-off level of switch is set so that the suction is always flooded. Clean vent hole.
Pump shuts off and turns on independent of switch, (trips thermal overload protector). CAUTION! Pump may start unexpectedly. Disconnect power supply.	<ol style="list-style-type: none"> 1. Incorrect voltage. 4. Excessive inflow or pump not properly sized for application. 8. Impeller jammed or loose on shaft, worn or damaged, impeller cavity or inlet plugged 12. Excessive water temperature (Internal protection only). 	<ol style="list-style-type: none"> 10. Check rotation. If power supply is three phase, reverse any two of three power supply leads to ensure proper impeller rotation. 11. Repair fixtures as required to eliminate leakage. 12. Check pump temperature limits & fluid temperature.
Pump operates noisily or vibrates excessively	<ol style="list-style-type: none"> 2c. Worn bearings, motor shaft bent 8. Debris in impeller cavity or broken impeller. 10. Pump running backwards. 13. Piping attachments to building structure too rigid or too loose. 	<ol style="list-style-type: none"> 13. Replace portion of discharge pipe with flexible connector. 14. Turn to automatic position. 15. Check for leaks around basin inlet and outlets.

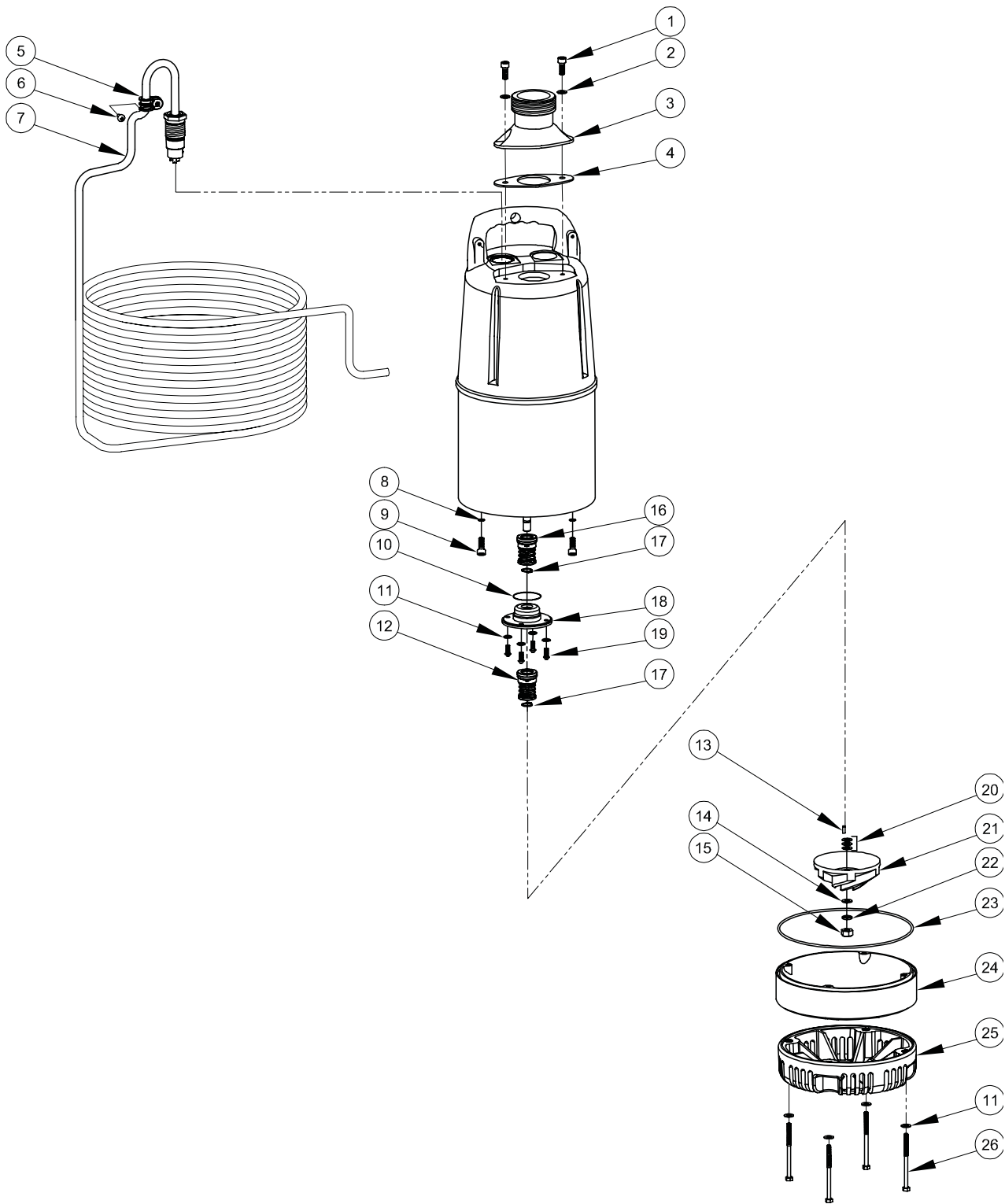

Figure 2

PARTS LIST

ITEM	QTY	PART NO.	DESCRIPTION
1	2	115084	SkHd Screw, M6 x 15, SS
2	2	115085	Flatwasher, 6mm, SS
3	1	115083	Discharge Outlet, 2" NPT
4	1	115086	Discharge Gasket
5	1	115081	Cable Clamp
6	1	115082	Self-Tapping Screw M4.8 x 16, SS
7	1	115079	Cable
8	2	115131	O-ring 6mm Dia. x 1.9mm
9	2	115130	SkHd Screw M6 x 10, SS
10	1	115124	O-ring 35mm Dia. x 3.1mm
11	8	115138	Flatwasher 5mm, SS
12	1	115123	Mechanical Seal
13	1	115140	Impeller Key, 3mm x 10mm, SS
14	1	115142	Flatwasher 8mm, SS
15	1	115141	Hex Nut, 8mm, SS
16	1	115129	Mechanical Seal
17	2	115106	Snap Ring
18	1		Seal Plate
19	4	115135	RdHd Screw, M5 x 10, SS
20	3	115139	Impeller Shim
21	1	115122A	1.25 HP (126 Series) Impeller
22	1	115143	Lockwasher, 8mm, SS
23	1		O-ring, 170mm Dia. x 3.1mm
24	1	115137	Suction Case
25	1	115145	Suction Strainer
26	4	115144	Screw, M5 x 72, SS
REPAIR PARTS KITS			
		115074	Cord Kit - Items 5, 6 & 7
		115075	Discharge Nozzle Kit - Items 1, 2, 3 & 4
		115077	Strainer Kit - Items 11, 25 & 26
		115127	1.25 HP Impeller Kit - Items 13, 14, 15, 20, 21, 22 & 24
		115076	Mechanical Seal Kit - Items 8, 9, 10, 11, 12, 16, 17 & 19

Repair parts are available in REPAIR PARTS KITS ONLY. Each kit contains an instruction sheet with procedures and illustrations to assist in replacement of the necessary parts

BARNES[®]

BARNES[®]
PRESSURE **PS** SYSTEMS



burks[®]

WEINMAN[®]

DEMING[®]

PROSSER[®]

Limited 24 Month Warranty

Crane Pumps & Systems warrants that products of our manufacture will be free of defects in material and workmanship under normal use and service for twenty-four (24) months after manufacture date, when installed and maintained in accordance with our instructions. This warranty gives you specific legal rights, and there may also be other rights which vary from state to state. In the event the product is covered by the Federal Consumer Product Warranties Law (1) the duration of any implied warranties associated with the product by virtue of said law is limited to the same duration as stated herein, (2) this warranty is a LIMITED WARRANTY, and (3) no claims of any nature whatsoever shall be made against us, until the ultimate consumer, his successor, or assigns, notifies us in writing of the defect, and delivers the product and/or defective part(s) freight prepaid to our factory or nearest authorized service station. Some states do not allow limitations on how long an implied warranty lasts, so the above limitation may not apply. **THE SOLE AND EXCLUSIVE REMEDY FOR BREACH OF ANY AND ALL WARRANTIES WITH RESPECT TO ANY PRODUCT SHALL BE TO REPLACE OR REPAIR AT OUR ELECTION, F.O.B. POINT OF MANUFACTURE OR AUTHORIZED REPAIR STATION, SUCH PRODUCTS AND/OR PARTS AS PROVEN DEFECTIVE. THERE SHALL BE NO FURTHER LIABILITY, WHETHER BASED ON WARRANTY, NEGLIGENCE OR OTHERWISE.** Unless expressly stated otherwise, guarantees in the nature of performance specifications furnished in addition to the foregoing material and workmanship warranties on a product manufactured by us, if any, are subject to laboratory tests corrected for field performance. Any additional guarantees, in the nature of performance specifications must be in writing and such writing must be signed by our authorized representative. Due to inaccuracies in field testing if a conflict arises between the results of field testing conducted by or for user, and laboratory tests corrected for field performance, the latter shall control. **RECOMMENDATIONS FOR SPECIAL APPLICATIONS OR THOSE RESULTING FROM SYSTEMS ANALYSES AND EVALUATIONS WE CONDUCT WILL BE BASED ON OUR BEST AVAILABLE EXPERIENCE AND PUBLISHED INDUSTRY INFORMATION. SUCH RECOMMENDATIONS DO NOT CONSTITUTE A WARRANTY OF SATISFACTORY PERFORMANCE AND NO SUCH WARRANTY IS GIVEN.**

This warranty shall not apply when damage is caused by (a) improper installation, (b) improper voltage (c) lightning (d) excessive sand or other abrasive material (e) scale or corrosion build-up due to excessive chemical content. Any modification of the original equipment will also void the warranty. We will not be responsible for loss, damage or labor cost due to interruption of service caused by defective parts. Neither will we accept charges incurred by others without our prior written approval.

This warranty is void if our inspection reveals the product was used in a manner inconsistent with normal industry practice and/or our specific recommendations. The purchaser is responsible for communication of all necessary information regarding the application and use of the product. **UNDER NO CIRCUMSTANCES WILL WE BE RESPONSIBLE FOR ANY OTHER DIRECT OR CONSEQUENTIAL DAMAGES, INCLUDING BUT NOT LIMITED TO TRAVEL EXPENSES, RENTED EQUIPMENT, OUTSIDE CONTRACTOR FEES, UNAUTHORIZED REPAIR SHOP EXPENSES, LOST PROFITS, LOST INCOME, LABOR CHARGES, DELAYS IN PRODUCTION, IDLE PRODUCTION, WHICH DAMAGES ARE CAUSED BY ANY DEFECTS IN MATERIAL AND/OR WORKMANSHIP AND/OR DAMAGE OR DELAYS IN SHIPMENT. THIS WARRANTY IS EXPRESSLY IN LIEU OF ANY OTHER EXPRESS OR IMPLIED WARRANTY, INCLUDING ANY WARRANTY OF MERCHANTABILITY OR FITNESS FOR A PARTICULAR PURPOSE.**

No rights extended under this warranty shall be assigned to any other person, whether by operation of law or otherwise, without our prior written approval.

CRANE[®]

A Crane Co. Company

PUMPS & SYSTEMS

420 Third Street
Piqua, Ohio 45356
Phone: (937) 778-8947
Fax: (937) 773-7157
www.cranepumps.com

83 West Drive, Brampton
Ontario, Canada L6T 2J6
Phone: (905) 457-6223
Fax: (905) 457-2650

**IMPORTANT!
WARRANTY REGISTRATION**

Your product is covered by the enclosed Warranty.
To complete the Warranty Registration Form go to:

<http://www.cranepumps.com/ProductRegistration/>

If you have a claim under the provision of the warranty, contact your local
Crane Pumps & Systems, Inc. Distributor.

RETURNED GOODS

**RETURN OF MERCHANDISE REQUIRES A "RETURNED GOODS AUTHORIZATION".
CONTACT YOUR LOCAL CRANE PUMPS & SYSTEMS, INC. DISTRIBUTOR.**



**Products Returned Must Be Cleaned, Sanitized,
Or Decontaminated As Necessary Prior To Shipment,
To Insure That Employees Will Not Be Exposed To Health
Hazards In Handling Said Material. All Applicable Laws
And Regulations Shall Apply.**

