

Inline 1-1/2" Circulator Pumps

- **Cast Iron or Silicon Bronze Construction with Silicon Bronze Impeller**
- **EPDM/EPR Mechanical Seal and Casing O-Ring Standard, Viton® Option Available**
- **Includes Mounting Flange Kit for 1-1/2" NPT**
- **Special Flange Designed to Accept B&G Flange or Standard 150lb 4-Bolt Flange**
- **Maximum Water Temperature 225° F (107° C)***
- **Maximum Flow 130 GPM**
- **Maximum Head 53 Ft. (23 PSI)**
- **1/8" NPT Seal Wash/Vent Port**
- **Single Phase or Three Phase TEFC 56C Motor**



5860-95
Cast Iron
Circulator
Pump

Performance of 1 1/2" Inline Circulator Pumps

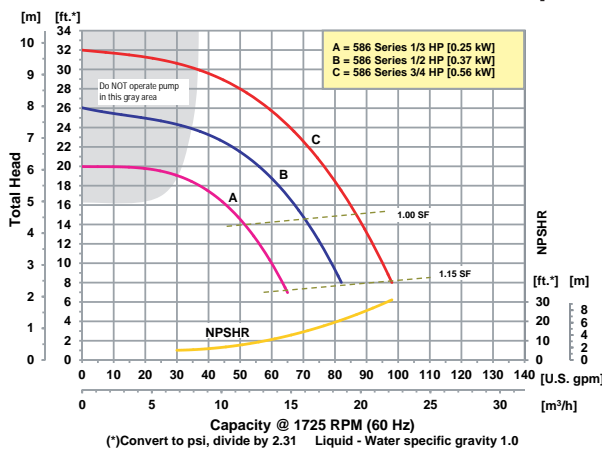

AMT Inline Circulator Pumps are designed for continuous duty industrial/commercial systems. Pumps are available in a variety of material configurations to meet your specifications. Pumps are powered by a 56C NEMA Totally Enclosed Fan Cooled (TEFC) frame electric motor with 1/2" conduit connection. Pumps are interchangeable with other manufacturers.

* Maximum temperature applies to water only.

Performance of 1 1/2" Inline Circulator Pumps

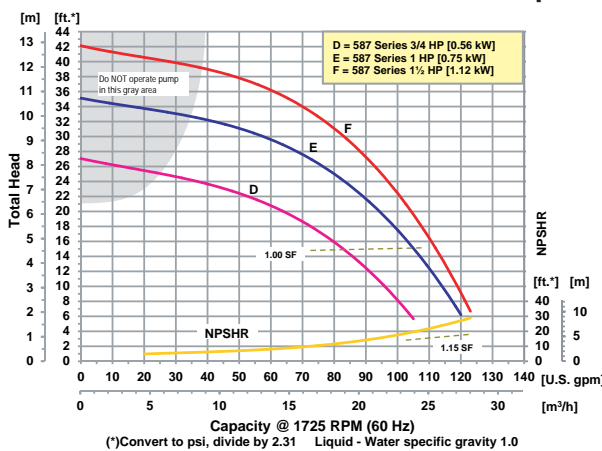

Performance of 1 1/2" Inline Circulator Pumps

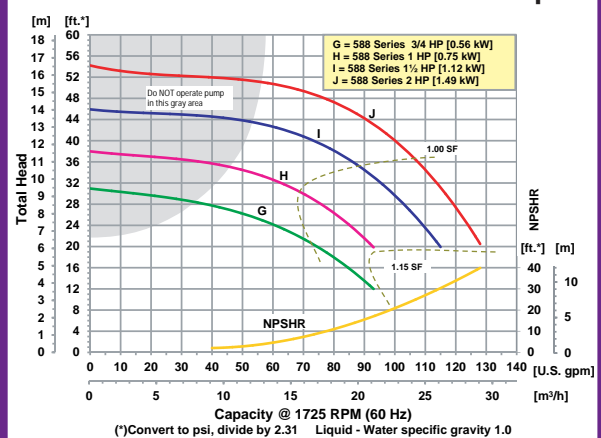

Pump Dimensional & Specification Data

Model ‡	Curve	HP	PH	ENC	Voltage @ 60 Hz +	Full Load Amps	A	B	C	D	E	F	G	L**	W	H	B & G Cast Iron Equiv	B & G Bronze Equiv	‡ Ship Wt. (Lbs.)
5864 5865	A	1/3	1 3	TEFC	115/230 230/460	7/4 2/1	5.4 [13.7]	6.5 [16.5]	3.1 [7.8]	1.4 [3.5]	0.5 [1.3]	4.0 [10.2]	4.0 [10.2]	19.5 [49.5]	8.0 [20.3]	11.5 [29.2]	S607S 607T	B607S B607T	80 77
5862 5863	B	1/2	1 3	TEFC	115/230 230/460	9/5 3/2	5.4 [13.7]	6.5 [16.5]	3.1 [7.8]	1.4 [3.5]	0.5 [1.3]	4.0 [10.2]	4.0 [10.2]	19.5 [49.5]	8.0 [20.3]	11.5 [29.2]	608S 608T	B608S B608T	84 80
5860 5861	C	3/4	1 3	TEFC	115/230 230/460	12/6 3/2	5.4 [13.7]	6.5 [16.5]	3.1 [7.8]	1.4 [3.5]	0.5 [1.3]	4.0 [10.2]	4.0 [10.2]	19.5 [49.5]	8.0 [20.3]	11.5 [29.2]	609S 609T	B609S B609T	90 84
5874 5875	D	3/4	1 3	TEFC	115/230 230/460	12/6 3/2	5.4 [13.7]	7.0 [17.8]	3.6 [9.1]	1.0 [2.5]	0.7 [1.8]	4.6 [11.7]	4.0 [10.2]	20.0 [50.8]	8.6 [21.8]	13.5 [34.3]	621S 621T	B621S B621T	87 86
5872 5873	E	1	1 3	TEFC	115/230 230/460	14/7 4/2	5.4 [13.7]	7.0 [17.8]	3.6 [9.1]	1.0 [2.5]	0.7 [1.8]	4.6 [11.7]	4.0 [10.2]	20.0 [50.8]	8.6 [21.8]	13.5 [34.3]	613S 613T	B613S B613T	92 90
5870 5871	F	1-1/2	1 3	TEFC	115/230 230/460	17/9 5/3	5.4 [13.7]	7.0 [17.8]	3.6 [9.1]	1.0 [2.5]	0.7 [1.8]	4.6 [11.7]	4.0 [10.2]	20.0 [50.8]	8.6 [21.8]	13.5 [34.3]	614S 614T	B614S B614T	102 94
5886 5887	G	3/4	1 3	TEFC	115/230 230/460	12/6 3/2	5.5 [13.9]	7.0 [17.8]	3.4 [8.6]	1.0 [2.5]	0.7 [1.8]	5.0 [12.7]	4.3 [10.9]	19.9 [50.5]	9.3 [23.6]	13.5 [34.3]	622S 622T	B622S B622T	89 87
5884 5885	H	1	1 3	TEFC	115/230 230/460	14/7 4/2	5.5 [13.9]	7.0 [17.8]	3.4 [8.6]	1.0 [2.5]	0.7 [1.8]	5.0 [12.7]	4.3 [10.9]	19.9 [50.5]	9.3 [23.6]	13.5 [34.3]	623S 623T	B623S B623T	94 92
5882 5883	I	1-1/2	1 3	TEFC	115/230 230/460	17/9 5/3	5.5 [13.9]	7.0 [17.8]	3.4 [8.6]	1.0 [2.5]	0.7 [1.8]	5.0 [12.7]	4.3 [10.9]	19.9 [50.5]	9.3 [23.6]	13.5 [34.3]	617S 617T	B617S B617T	104 96
5880 5881	J	2	1 3	TEFC	115/230 230/460	22/11 6/3	5.5 [13.9]	7.0 [17.8]	3.4 [8.6]	1.0 [2.5]	0.7 [1.8]	5.0 [12.7]	4.3 [10.9]	19.9 [50.5]	9.3 [23.6]	13.5 [34.3]	618S 618T	B618S B618T	105 97

** This dimension may vary due to the motor manufacturer's specifications.

(+) 3-Phase models can also operate on 50 Hz. (This will change full load amps, service factor and RPM.)

NOTE: Dimensions are in inches (centimeters) and have a tolerance of ± 1/8"

NOTE: Electric supply for all motors must be within ±10% of nameplate voltage rating (Ex. 230V ± 10%= 207 to 253)

XCI (-95) = Cast Iron Construction with Bronze Impeller
XB (-97) = Cast Bronze Construction with Bronze Impeller

PUMPS ARE DESIGNED TO MOUNT HORIZONTALLY OR VERTICALLY

‡ When Ordering Add the Correct Suffix (-9x) Suffix to Model Number Indicating Material Selection.

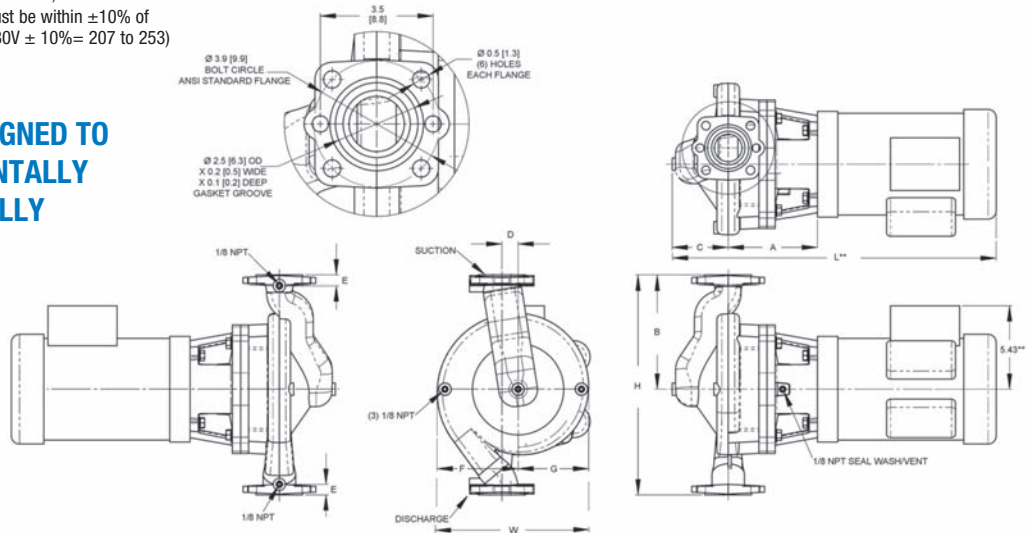

Standard Features

- Includes Mounting Flange Kit for 1-1/2" NPT; Includes (2) Flanges, (2) Gaskets and Fasteners
- Steel Shaft with Sealed Ball Bearing Design Permits Removal of Motor Without Disconnecting Pump or Loss of Liquid
- Special Flange Designed to Accept B&G Flange or Standard 150 Lb. 4 bolt Flanges
- High Efficiency Closed Bronze Impeller
- 1/8" NPT Seal Wash/Vent Port
- Available in Either Single or Three Phase TEFC 56C Motors with Standard NEMA Mounting Dimensions
- EPDM/EPR Mechanical Seal and Casing O-Ring Standard
- Maximum Working Pressure 150 PSI
- Optional Viton® Mechanical Seals and O-Rings Available
- Stainless Steel (300 Series) Sleeve Protects Stub Shaft from Liquid