

Please read and save this Repair Parts Manual. Read this manual and the General Operating Instructions carefully before attempting to assemble, install, operate or maintain the product described. Protect yourself and others by observing all safety information. The Safety Instructions are contained in the General Operating Instructions. Failure to comply with the safety instructions accompanying this product could result in personal injury and/or property damage! Retain instructions for future reference. AMT reserves the right to discontinue any model or change specifications at any time without incurring any obligation.

©2006 American Machine & Tool Co., Inc. of PA, A Subsidiary of The Gorman-Rupp Company, All Rights Reserved.

WARNING Periodic maintenance and inspection is required on all pumps to insure proper operation. Unit must be clear of debris and sediment. Inspect for leaks and loose bolts. Failure to do so voids warranty.

Submersible Pumps

Contractor Series

Refer to pump manual 1808-636-00 for General Operating and Safety Instructions.

Description

These versatile centrifugal Submersible Contractor pumps are intended for use in residential, commercial, and industrial settings. Examples include: Construction sites, waste water, storm water, farming, mines, marine, basement, and other general drainage applications involving sediment laden liquids with small solids (see size chart below). Submersible design means low noise and no priming issues. Each unit is completely assembled and includes a self-cleaning semi-open impeller featuring abrasion-resistant high chromium steel

construction for durability. Pumps incorporate a mechanical shaft seal with long lasting silicon carbide war faces and feature a secondary shaft seal and oil chamber. Pumps have a 3450 RPM electric motor fitted with an unfinished power cord that requires field wiring (no controls are supplied). Motors are rated continuous duty and single phase units have automatic restart thermal overload protection. Handle liquids from 40° to 104° F (4° to 40° C). For use with non-flammable liquids compatible with pump component materials.

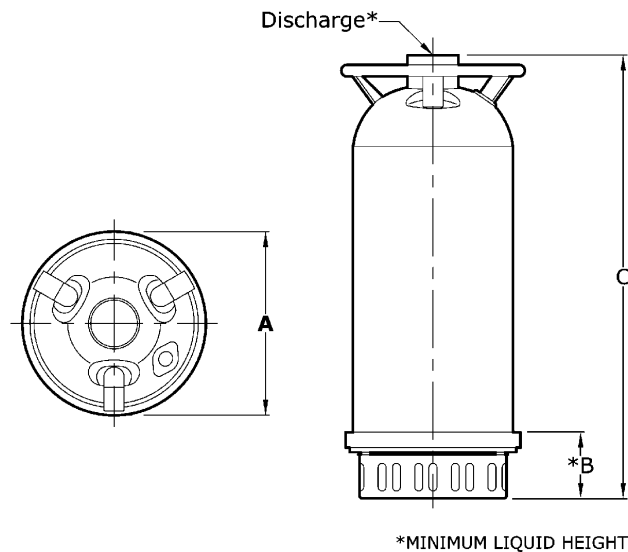

Figure 1 - Dimensions

Model	Dis*	A	CP	W (Minimum liquid height)	Max. solid
5771	2"	8.27	19.29	2.76	3/8
5773	2"	8.98	25.60	3.15	3/8
5777	3"	8.98	26.38	3.15	3/8
577A/577B	3"	9.13	23.82	3.94	3/8
577D/577E	4"	10.71	28.35	4.92	3/8

(*) Standard NPT (female) pipe thread.

Specifications

Model	Discharge Outlet ‡	HP	Power Supply @ 60 Hz	Max. Amps	Cord Length	Basic Construction	Impeller Material	Seal
5771	2"	1.0	230VAC, 1 Phase	7.0	18 ft.	Cast Iron*	HCS	Buna N
5773	2"	2.0	230VAC, 1 Phase	10.9	32 ft.	Cast Iron*	HCS	Buna N
5777	3"	3.0	230VAC, 1 Phase	17.2	32 ft.	Cast Iron*	HCS	Buna N
577A	3"	5.0	230VAC, 3 Phase	13.9	32 ft.	Cast Iron*	HCS	Buna N
577B	3"	5.0	460VAC, 3 Phase	7.0	32 ft.	Cast Iron*	HCS	Buna N
577D	4"	7.5	230VAC, 3 Phase	19.5	32 ft.	Cast Iron*	HCS	Buna N
577E	4"	7.5	460VAC, 3 Phase	10.3	32 ft.	Cast Iron*	HCS	Buna N

NOTE: Driver data is subject to change without notice, see label on driver for actual specifications.

(‡) Standard NPT (female) pipe thread

(HCS) High Chromium Steel

(*) With stainless steel and plastic components

Performance Chart

Model	GPM AT TOTAL HEAD IN FEET						*Max. Head
	5'	10'	20'	40'	60'	80'	
5771	---	85	62	20	--	--	48
5773	---	125	110	78	35	---	74
5777	---	210	182	120	42	---	68
577A/577B	---	234	215	168	102	30	88
577D/577E	---	440	410	325	190	---	78

(†) Shutoff; to convert to psi, divide by 2.31

(N/R) Not recommended

Maintenance

▲WARNING *Make certain that unit is disconnected from power source before attempting to service or remove any component.*

POWER CORD REPLACEMENT

Periodically inspect power cord and replace whenever abrasion, cracking, softening, or other signs of deterioration are found.

Refer to Figures 2 and 3.

- Place unit on workbench in upright position.
- Remove two fasteners (Ref. No. 39) which hold outer cord retainer (Ref. No. 38).
- Remove fastener(s) (Ref. No. 5) at handle (Ref. NO. 6) to free wire loom (Ref. No. 2).
- Remove three fasteners (Ref. No. 36) to detach handle and outer shell (Ref. No. 37). Shell can now be slid off towards top of pump.
- Clean dirt and rust from around wire cover (Ref. No. 7).
- Remove two fasteners (Ref. No. 4) which hold inner cord retainer (Ref. No. 3).

- Remove four fasteners (Ref. No. 10) which hold wire cover in place.
- Carefully pry cover from unit with screwdriver.

IMPORTANT: Be careful to keep rust and other debris from falling into motor housing during cover removal.

- Take note of proper wire configuration and connect new power cord (Ref. No. 1) in identical fashion.

▲WARNING *If unsure about above information or wiring diagrams, consult an electrician familiar with motor wiring.*

- Clean sealing flanges if necessary and reassemble pump in reverse order.

IMPELLER INSPECTION / REPLACEMENT

If pump develops poor performance characteristics, impeller may be worn or clogged.

IMPELLER INSPECTION
 Refer to Figure 3.

- Place unit on workbench in horizontal position and clean rust and buildup from around pump-to-motor flange.
- Remove four short fasteners (Ref. No. 15) which attach base (Ref. No. 30) to unit.
- Pry base off with screwdriver. Rap down on pump body with soft mallet if necessary to separate parts.
- Inspect impeller (Ref. No. 26). If clog is found, remove debris and reassemble in reverse order. If damage to impeller is found, such as pitting, deep grooves, or breakage, proceed to next section.

IMPELLER REPLACEMENT

- Remove impeller fastener (Ref. No. 28) by unscrewing in counterclockwise direction.

NOTE: To prevent motor shaft from turning, wedge a screwdriver between impeller vane and locknut (see Figure 2).

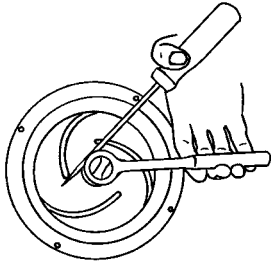

Figure 2 - Impeller Removal

6. Slide off impeller washer (Ref. No. 27). Impeller is keyed to motor shaft and can now be pulled free.
7. Install replacement impeller and reassemble in reverse order.

MECHANICAL SEAL REPLACEMENT

Motor internals are protected from contact with liquid being pumped by a mechanical shaft seal and oil cavity. When seal wears out, potential motor life will be compromised. Therefore, periodic seal replacement is recommended. Time interval between replacements will depend on abrasiveness of liquid being pumped, temperature, total accumulated runtime, etc.

IMPORTANT: Always replace seal head (Ref. No. 18) and both seal seats (Ref. Nos. 17 & 19) at same time to insure proper mating of components.

Refer to Figure 3.

1. Disassemble pump by following directions in both "Power Cord Replacement" and "Impeller Inspection/Replacement" sections.
2. With unit on its side and outer

shell, wire cover, pump assembly and impeller removed, lift shaft key (Ref. No. 13) from shaft using a pliers.

3. Clean rust and buildup from unit.
4. From top of unit, remove four long fasteners (Ref. No. 10) which attach lower end bell (Ref. No. 16) to motor case (Ref. No. 11).
5. Rap on ears of lower end bell with a soft mallet to break it free from motor case. Then carefully guide lower end bell along with shaft/rotor and bearing assembly out of motor case.
6. Drain oil from seal cavity by removing drain screw (Ref. No. 23) and seal (Ref. No. 22) from seal plate (Ref. No. 21). Then tip components upright overtop of a catch pan until oil is drained.
7. Remove three fasteners (Ref. No. 25) and pry out seal plate with screwdriver. Slinger washer (Ref. No. 24) will come free at this time.
8. Use a press or gear puller to remove shaft and bearings from lower end bell. Shaft seal head will now be free.

IMPORTANT: Shaft seal head (with spring) has unique ends, and two seal seats are different from one another. Be sure to note size and color of each before disassembly so that new parts are installed in proper orientation.

9. Remove upper seal seat (Ref. No. 17) from lower end bell by using a screwdriver or dowel to press on seal from rear. Do the same for lower seal seat (Ref. No. 19) in seal plate.
10. Clean seal seat cavities before inserting new seals.
11. Carefully wipe polished surface of

new seal seats with a clean cloth.

12. Wet outside of rubber portion of seal seats with a light coating of soapy water.
13. Press each new seal seat squarely into cavity in both seal plate and lower end bell. If seal seat does not press squarely into cavity, it can be adjusted into place by pushing on it carefully with a piece of pipe or dowel. Always use a piece of cardboard between pipe and seal seat to avoid scratching seal seat (This is a lapped surface and must be handled very carefully).
14. After each seal seat is in place, insure that it is clean and has not been marred.
15. Using a clean cloth, wipe shaft and make certain that it is perfectly clean.
16. Carefully guide motor shaft through seal seat and use a press to seat bearing back into lower end bell.
17. Apply a light coating of soapy water to inside rubber portion of seal head and slide onto shaft (be sure to start correct end first).
18. Place seal plate back onto lower end bell being careful to guide shaft and avoid damage to seal seat. Secure with fasteners.
19. Press slinger washer back in place.
20. Refill cavity with oil through fill hole and reassembly in reverse order.

Specifications Information and Repair Parts Manual
Submersible Pumps Contractor Series

5771-95, 5773-95, 5777-95, 577A-95,
577B-95, 577D-95, 577E-95

Ref. No.	Description	2" 1 HP	2" - 1 HP	3" - 3 HP	3" - 5 HP	4" - 7-1/2 HP	Qty.
		5771-95	5773-95	5777-95	577A-95 577B-95	577D-95 577E-95	
1	Power cord kit ~ (230 vac Models)	5771-350-90	5773-350-90	5777-350-90	577A-350-90	577D-350-90	1
2	Power cord kit ~ (460 vac Models)	—	—	—	577B-350-90	577E-350-90	1
3	Wire loom	(See Ref. No. 1)	(See Ref. No. 1)	(See Ref. No. 1)	(See Ref. No. 1)	(See Ref. No. 1)	1
4	Inner retainer	(See Ref. No. 1)	(See Ref. No. 1)	(See Ref. No. 1)	(See Ref. No. 1)	(See Ref. No. 1)	1
5	Fastener	(See Ref. No. 1)	(See Ref. No. 1)	(See Ref. No. 1)	(See Ref. No. 1)	(See Ref. No. 1)	2
6	Fastener	*	*	*	*	*	2
7	Handle kit	5771-100-90	5773-100-90	5777-100-90	577A-100-90	577D-100-90	1
8	Wire cover	—	—	—	—	—	—
9	Fastener	*	*	*	*	*	4
10	Seal	(See Ref. No. 35)	(See Ref. No. 35)	(See Ref. No. 35)	(See Ref. No. 35)	(See Ref. No. 35)	1
11	Fastener	—	—	—	—	—	—
12	Motor case	—	—	—	—	—	—
13	Shaft/rotor	—	—	—	—	—	—
14	Shaft key	—	—	—	—	—	—
15	Seal	(See Ref. No. 35)	(See Ref. No. 35)	(See Ref. No. 35)	(See Ref. No. 35)	(See Ref. No. 35)	1
16	Fastener	*	*	*	*	*	4
17	Lower end bell	—	—	—	—	—	—
18	Upper seal seat	(See Ref. No. 35)	(See Ref. No. 35)	(See Ref. No. 35)	(See Ref. No. 35)	(See Ref. No. 35)	1
19	Seal head	(See Ref. No. 35)	(See Ref. No. 35)	(See Ref. No. 35)	(See Ref. No. 35)	(See Ref. No. 35)	1
20	Lower seal seat	(See Ref. No. 35)	(See Ref. No. 35)	(See Ref. No. 35)	(See Ref. No. 35)	(See Ref. No. 35)	1
21	Seal	(See Ref. No. 35)	(See Ref. No. 35)	(See Ref. No. 35)	(See Ref. No. 35)	(See Ref. No. 35)	1
22	Seal plate	—	—	—	—	—	—
23	Seal	(See Ref. No. 35)	(See Ref. No. 35)	(See Ref. No. 35)	(See Ref. No. 35)	(See Ref. No. 35)	1
24	Drain plug	*	*	*	*	*	1
25	Slinger washer	(See Ref. No. 35)	(See Ref. No. 35)	(See Ref. No. 35)	(See Ref. No. 35)	(See Ref. No. 35)	1
26	Fastener	*	*	*	*	*	4
27	Impeller	(See Ref. No. 34)	(See Ref. No. 34)	(See Ref. No. 34)	(See Ref. No. 34)	(See Ref. No. 34)	1
28	Impeller washer	(See Ref. No. 34)	(See Ref. No. 34)	(See Ref. No. 34)	(See Ref. No. 34)	(See Ref. No. 34)	1
29	Impeller fastener	(See Ref. No. 34)	(See Ref. No. 34)	(See Ref. No. 34)	(See Ref. No. 34)	(See Ref. No. 34)	1
30	Flange kit	—	—	5777-001-90	577A-001-90	577D-001-90	1
31	Base	(See Ref. No. 34)	(See Ref. No. 34)	(See Ref. No. 34)	(See Ref. No. 34)	(See Ref. No. 34)	1
32	Fastener	(See Ref. No. 34)	(See Ref. No. 34)	(See Ref. No. 34)	(See Ref. No. 34)	(See Ref. No. 34)	4
33	Strainer kit	5771-170-90	5773-170-90	5777-170-90	577A-170-90	5771-170-90	1
34	Fastener	*	*	*	*	*	3
35	Δ Wearplate/impeller kit	5771-010-90	5773-010-90	5777-010-90	577A-010-90	577D-010-90	1
36	‡ Seal kit	5771-300-90	5773-300-90	5777-300-90	577A-300-90	577D-300-90	1
37	Fastener	*	*	*	*	*	3
38	Outer shell	—	—	—	—	—	—
39	Outer retainer	—	—	—	—	—	—
40	Fastener	*	*	*	*	*	2
41	Δ Start Capacitor	5761-351-00	5763-351-00	5763-351-00	—	—	1
42	Δ Run Capacitor	—	5761-351-00	5761-351-00	—	—	1

(-) Not available

(*) Standard hardware item, available locally

(~) Power cord kit includes Ref. Nos. 1, 2, 3, 4

(Δ) Not shown. Wearplate and impeller kit includes Ref. Nos. 26, 27, 28, 30, 31

(‡) Not shown. Seal kit includes Ref. Nos. 9, 14, 17, 18, 19, 20, 22, 24

For Repair Parts, contact dealer where pump was purchased.

Please provide the following information:

- Model number
- Serial number (if any)
- Part description and number as shown in parts list

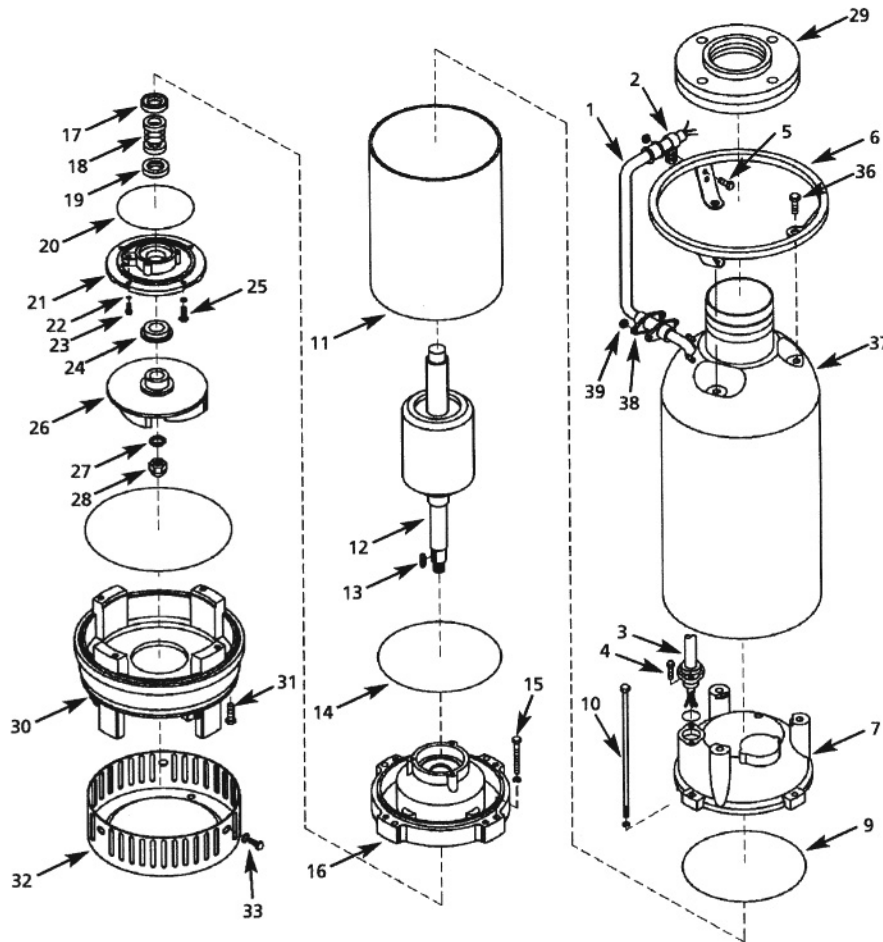

Figure 3 - Repair Parts Illustration