

Please read and save this Repair Parts Manual. Read this manual and the General Operating Instructions carefully before attempting to assemble, install, operate or maintain the product described. Protect yourself and others by observing all safety information. The Safety Instructions are contained in the General Operating Instructions. Failure to comply with the safety instructions accompanying this product could result in personal injury and/or property damage! Retain instructions for future reference.

# Stamped Stainless Steel Centrifugal Pumps

Refer to form 1808-634-00 for General Operating and Safety Instructions.

## Description

These centrifugal pumps are non-self priming (gravity feed) units designed for continuous duty liquid transfer and re-circulation. Pumps are intended for use with clear, non-abrasive, non-flammable liquids compatible with pump component materials. Handle liquids from 40° to 200° F (4° to 93° C) with standard Viton seals, or 40° to 180° F (4° to 82° C) with optional Buna-N seals. Wetted parts include: 316 Stainless Steel impeller and impeller nut; 304 Stainless Steel Casing and Casing Cover; Type 21 Mechanical Shaft Seal comprised of carbon, ceramic, and stainless steel components; and Viton seals (Buna-N seals optional). High head units also include wetted Stainless Steel motor shaft. The discharge port on all models can be rotated 360° in 90° increments to accommodate specific applications.

## PUMPS

Motorized units are direct coupled to a 3450 RPM motor (see "Specifications" for additional motor data). Single phase pump motors have automatic reset thermal protection. All models are manual mode and require field wiring, no controls are supplied. Check motor wiring before putting unit into operation (see motor nameplate for specific wiring diagram).

## PUMP HEADS

Some models are not equipped with motors. They are suitable for mounting to 3450 RPM, NEMA 56J face threaded shaft motors, with counterclockwise rotation (looking at motor shaft). To find motor's available horsepower multiply motor's rated horsepower by service factor. This number must be equal to or greater than that required by pump. To determine minimum horsepower requirements of pump see chart at right.

## PUMP HEADS (CONTINUED)

Model	Req'd HP
5470-K8	0.75
5480-K8	1.00
5484-K8, 5538-K8	1.50
5490-K8, 5534-K8	2.00
5494-K8, 5530-K8	3.00

## Performance

Model	HP	GPM of Water at Total Head in Feet						Max Head*
		10'	30'	50'	70'	90'	100'	
High Volume Models:								
5470-98, 5471-98, 5472-98, 5473-98	3/4	52	38	18	–	–	–	65 ft
5480-98, 5481-98, 5482-98, 5483-98	1	84	57	24	–	–	–	65
5484-98, 5485-98, 5486-98, 5487-98	1½	108	81	44	–	–	–	65
5490-98, 5491-98, 5492-98, 5493-98	2	114	92	55	–	–	–	68
High Head Models:								
5494-98, 5495-98, 5496-98, 5497-98	3	144	116	85	38	–	–	81
5538-98, 5539-98, 553A-98, 553B-98	1½	97	82	66	48	21	–	99
5534-98, 5535-98, 5536-98, 5537-98	2	105	93	79	62	39	23	109
5530-98, 5531-98, 5532-98, 5533-98	3	116	105	94	81	67	59	144

(\*) Shut-off; to convert to psi, divide by 2.31.

# Stamped Stainless Steel Centrifugal Pumps

## Specifications

DRIVER						PUMP Port Size (Inches)*	Ship Weight (Lbs.)
Model	HP	Phase	Enclosure	Volts	Hertz		
5470-98	3/4	1	ODP	115/230	60	1¼ x 3/4	28
5471-98	3/4	1	TEFC	115/230	60	1¼ x 3/4	30
5472-98	3/4	3	ODP	230/460	60/50	1¼ x 3/4	28
5473-98	3/4	3	TEFC	230/460	60/50	1¼ x 3/4	28
5480-98	1	1	ODP	115/230	60	1½ x 1¼	33
5481-98	1	1	TEFC	115/230	60	1½ x 1¼	34
5482-98	1	3	ODP	230/460	60/50	1½ x 1¼	32
5483-98	1	3	TEFC	208-230/460	60/50	1½ x 1¼	30
5484-98	1½	1	ODP	115/230	60	1½ x 1¼	34
5485-98	1½	1	TEFC	115/230	60	1½ x 1¼	42
5486-98	1½	3	ODP	230/460	60/50	1½ x 1¼	35
5487-98	1½	3	TEFC	230/460	60/50	1½ x 1¼	36
5490-98	2	1	ODP	115/230	60	2 x 1½	42
5491-98	2	1	TEFC	230	60	2 x 1½	47
5492-98	2	3	ODP	230/460	60	2 x 1½	41
5493-98	2	3	TEFC	230/460	60/50	2 x 1½	42
5494-98	3	1	ODP	230	60	2 x 1½	50
5495-98	3	1	TEFC	230	60	2 x 1½	53
5496-98	3	3	ODP	230/460	60	2 x 1½	48
5497-98	3	3	TEFC	230/460	60/50	2 x 1½	50
5538-98	1½	1	ODP	115/230	60	1½ x 1¼	39
5539-98	1½	1	TEFC	115/230	60	1½ x 1¼	47
553A-98	1½	3	ODP	230/460	60/50	1½ x 1¼	40
553B-98	1½	3	TEFC	230/460	60/50	1½ x 1¼	41
5534-98	2	1	ODP	115/230	60	1½ x 1¼	47
5535-98	2	1	TEFC	230	60	1½ x 1¼	52
5536-98	2	3	ODP	230/460	60	1½ x 1¼	46
5537-98	2	3	TEFC	230/460	60/50	1½ x 1¼	47
5530-98	3	1	ODP	230	60	1½ x 1¼	55
5531-98	3	1	TEFC	230	60	1½ x 1¼	58
5532-98	3	3	ODP	230/460	60	1½ x 1¼	53
5533-98	3	3	TEFC	230/460	60/50	1½ x 1¼	55

(ODP) Open Drip Proof; (TEFC) Totally Enclosed Fan Cooled

(\*) Standard NPT (female) pipe thread.

**NOTE:** Driver data is subject to change without notice, see label on driver for actual specifications.

## Assembly

### MOTOR (FOR UNITS SHIPPED WITHOUT DRIVER ONLY)

(Refer to Figure 2 & 3)

**CAUTION** *If any parts are missing or damaged, do not attempt to assemble or operate pump until repair parts are obtained and properly installed.*

1. Verify that motor (Ref. No. 1) conforms to ALL standards specified in "Description", and is equipped with slinger washer (Ref. No. 2) not included with pump.

2. Place motor in vertical position with shaft end up. Set adapter (Ref. No. 3) on top of motor.

**NOTE:** Be sure to align adapter in desired position now. Rotating adapter allows pump discharge port to be positioned at various angles.

3. (For high head models only) Use fasteners and washers (Ref. Nos. 4 & 5) to attach adapter to motor.
4. See "INSTALLATION OF NEW SEAL" under "Maintenance" section and follow steps to complete assembly of pump.

## Maintenance

**WARNING** *Make certain that unit is disconnected from power source before attempting to service or remove any components!*

### SHAFT SEAL REPLACEMENT

(Refer to Figure 2)

#### REMOVAL OF OLD SHAFT SEAL

1. Disconnect power supply and piping.
2. Place unit in vertical position with pump end up.
3. Disassemble pump by removing fasteners and washers (Ref. Nos. 13 & 14) which hold casing (Ref. No. 12) in

# Models 5470 thru 5497 and 5530 thru 553B

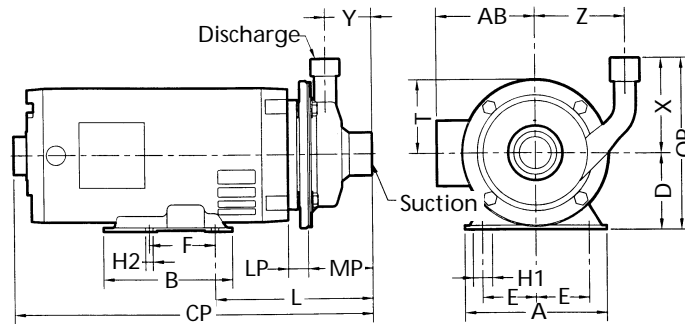

Figure 1 - Dimensions

## Dimensions (Inches)

Model	CP*	AB*	A	B	D	E	F	H1	H2	L	LP	MP	OP	T	X	Y	Z
5470-98	12.57	3.38	6.50	3.88	3.50	2.44	3.00	0.88	0.34	6.50	0.93	3.00	7.87	3.38	4.37	2.15	4.13
5471-98	13.99	4.88	6.50	3.88	3.50	2.44	3.00	0.88	0.34	6.50	0.93	3.00	7.87	3.38	4.37	2.15	4.13
5472-98	12.82	3.38	6.50	3.88	3.50	2.44	3.00	0.88	0.34	6.50	0.93	3.00	7.87	3.38	4.37	2.15	4.13
5473-98	13.37	4.88	6.50	3.88	3.50	2.44	3.00	0.88	0.34	6.50	0.93	3.00	7.87	3.38	4.37	2.15	4.13
5480-98	12.65	3.38	6.50	3.88	3.50	2.44	3.00	0.88	0.34	6.07	0.93	2.58	7.87	3.38	4.37	1.79	4.00
5481-98	13.95	4.88	6.50	3.88	3.50	2.44	3.00	0.88	0.34	6.07	0.93	2.58	7.87	3.38	4.37	1.79	4.00
5482-98	12.78	3.38	6.50	3.88	3.50	2.44	3.00	0.88	0.34	6.07	0.93	2.58	7.87	3.38	4.37	1.79	4.00
5483-98	13.57	3.38	6.50	3.88	3.50	2.44	3.00	0.88	0.34	6.07	0.93	2.58	7.87	3.38	4.37	1.79	4.00
5484-98	13.03	3.38	6.50	3.88	3.50	2.44	3.00	0.88	0.34	6.07	0.93	2.58	7.87	3.38	4.37	1.79	4.00
5485-98	14.82	4.56	6.50	3.88	3.50	2.44	3.00	0.88	0.34	6.07	0.93	2.58	7.87	3.38	4.37	1.79	4.00
5486-98	13.28	3.38	6.50	3.88	3.50	2.44	3.00	0.88	0.34	6.07	0.93	2.58	7.87	3.38	4.37	1.79	4.00
5487-98	13.95	4.88	6.50	3.88	3.50	2.44	3.00	0.88	0.34	6.07	0.93	2.58	7.87	3.38	4.37	1.79	4.00
5490-98	13.74	3.38	6.50	3.88	3.50	2.44	3.00	0.88	0.34	6.16	0.93	2.67	7.87	3.38	4.37	1.88	4.00
5491-98	15.29	4.56	6.50	3.88	3.50	2.44	3.00	0.88	0.34	6.16	0.93	2.67	7.87	3.38	4.37	1.88	4.00
5492-98	13.87	3.38	6.50	3.88	3.50	2.44	3.00	0.88	0.34	6.16	0.93	2.67	7.87	3.38	4.37	1.88	4.00
5493-98	14.16	4.88	6.50	3.88	3.50	2.44	3.00	0.88	0.34	6.16	0.93	2.67	7.87	3.38	4.37	1.88	4.00
5494-98	14.99	3.13	6.50	3.88	3.50	2.44	3.00	0.88	0.34	6.16	0.93	2.67	7.87	3.38	4.37	1.88	4.00
5495-98	16.16	4.88	6.50	3.88	3.50	2.44	3.00	0.88	0.34	6.16	0.93	2.67	7.87	3.38	4.37	1.88	4.00
5496-98	14.74	3.38	6.50	3.88	3.50	2.44	3.00	0.88	0.34	6.16	0.93	2.67	7.87	3.38	4.37	1.88	4.00
5497-98	15.66	4.88	6.50	3.88	3.50	2.44	3.00	0.88	0.34	6.16	0.93	2.67	7.87	3.38	4.37	1.88	4.00
5530-98	16.35	—	6.50	3.88	3.50	2.44	3.00	0.88	0.34	7.52	1.44	3.52	12.00	4.33	8.50	2.55	2.19
5531-98	17.52	4.88	6.50	3.88	3.50	2.44	3.00	0.88	0.34	7.52	1.44	3.52	12.00	4.33	8.50	2.55	2.19
5532-98	16.10	—	6.50	3.88	3.50	2.44	3.00	0.88	0.34	7.52	1.44	3.52	12.00	4.33	8.50	2.55	2.19
5533-98	17.02	4.88	6.50	3.88	3.50	2.44	3.00	0.88	0.34	7.52	1.44	3.52	12.00	4.33	8.50	2.55	2.19
5534-98	15.10	—	6.50	3.88	3.50	2.44	3.00	0.88	0.34	7.52	1.44	3.52	12.00	4.33	8.50	2.55	2.19
5535-98	16.65	4.56	6.50	3.88	3.50	2.44	3.00	0.88	0.34	7.52	1.44	3.52	12.00	4.33	8.50	2.55	2.19
5536-98	15.23	—	6.50	3.88	3.50	2.44	3.00	0.88	0.34	7.52	1.44	3.52	12.00	4.33	8.50	2.55	2.19
5537-98	15.52	4.88	6.50	3.88	3.50	2.44	3.00	0.88	0.34	7.52	1.44	3.52	12.00	4.33	8.50	2.55	2.19
5538-98	14.48	—	6.50	3.88	3.50	2.44	3.00	0.88	0.34	7.52	1.44	3.52	12.00	4.33	8.50	2.55	2.19
5539-98	16.27	4.88	6.50	3.88	3.50	2.44	3.00	0.88	0.34	7.52	1.44	3.52	12.00	4.33	8.50	2.55	2.19
553A-98	14.73	—	6.50	3.88	3.50	2.44	3.00	0.88	0.34	7.52	1.44	3.52	12.00	4.33	8.50	2.55	2.19
553B-98	15.40	4.88	6.50	3.88	3.50	2.44	3.00	0.88	0.34	7.52	1.44	3.52	12.00	4.33	8.50	2.55	2.19

**NOTE:** All dimensions have a tolerance of  $\pm 1/8"$ .

(\*) This dimension may vary due to motor manufacturer's specifications.

### Maintenance (Continued)

place. Lift off casing and casing seal (Ref. No. 11).

- Unscrew impeller nut (Ref. No. 10), and impeller (Ref. No. 8) separately by turning each counterclockwise. Impeller seal (Ref. No. 9) will also be

freed at this time. If seal head (Ref. No. 7 with spring) is retained on impeller, separate at this time.

**NOTE:** It may be necessary to use a soft hammer to tap outside of impeller in a counterclockwise direction to loosen it.

**NOTE:** Access to motor shaft is provided

at end opposite pump (plug may need to be pried out or cover removed). Use screwdriver in slot or wrench on flats to keep motor shaft from turning.

- Lift off casing cover (Ref. No. 6) while pulling seal along with it. Seal seat (without spring) can now be freed by

**For Repair Parts contact dealer where pump was purchased.**

Please provide following information:

- Model number
- Serial number (if any)
- Part description and number as shown in parts list

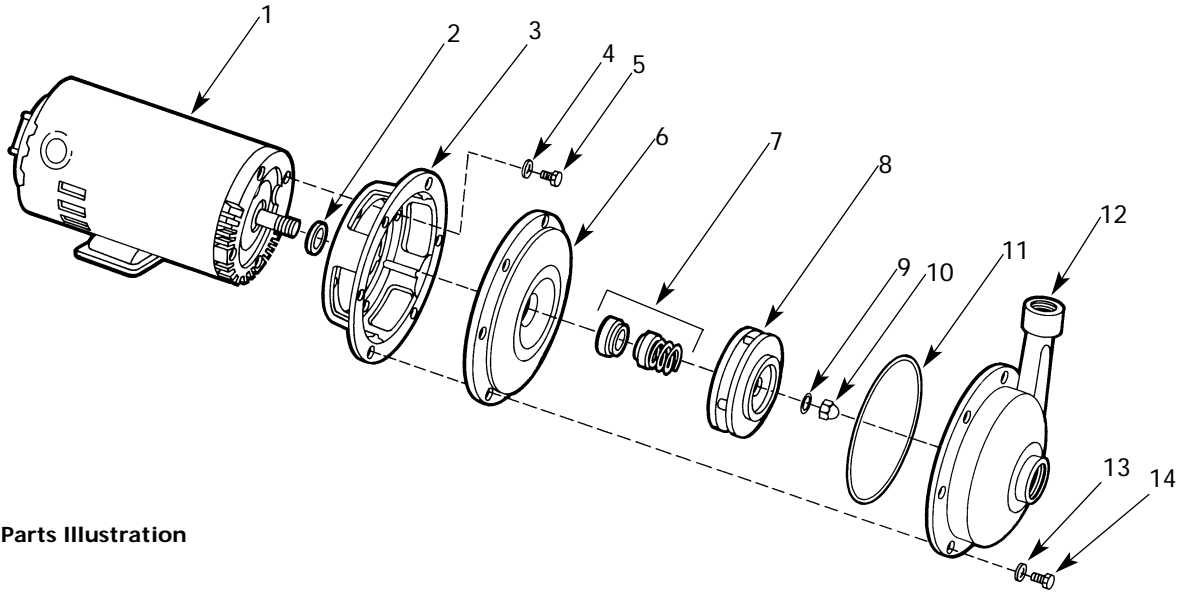

Figure 2 - Repair Parts Illustration

**Repair Parts List**

Ref. No.	Description	Part Number for Models:					Qty.	
		(3/4 HP)	(1 HP)	(1 1/2 HP)	(2 HP)	(3 HP)		
1	‡ Motor	-1 Phase ODP	1626-010-00	1626-011-00	1626-012-00	1626-024-00	1626-026-00	1
		-3 Phase ODP	1626-014-00	1626-015-00	1626-016-00	1626-025-00	1626-027-00	
		-1 Phase TEFC	1626-051-00	1626-069-00	1626-050-00	1626-070-00	1626-071-00	
		-3 Phase TEFC	1626-052-00	1626-077-00	1626-077-00	1626-054-00	1626-072-00	
2	Slinger washer	1534-000-00	1534-000-00	1534-000-00	1534-000-00	1534-000-00	1	
3	Adapter	5470-030-09	5470-030-09	5470-030-09	5470-030-09	5470-030-09	1	
4	Washer	—	—	—	—	—	—	
5	Fastener	—	—	—	—	—	—	
6	Casing cover	5470-020-00	5470-020-00	5470-020-00	5470-020-00	5470-020-00	1	
7	Shaft seal assembly-Viton	1640-162-98	1640-162-98	1640-162-98	1640-162-98	1640-162-98	1	
8	Impeller	5470-010-09	5470-010-08	5481-010-09	5481-010-09	5491-010-09	1	
9	Impeller seal-Viton	*	*	*	*	*	1	
10	Impeller nut	1784-001-00	1784-001-00	1784-001-00	1784-001-00	1784-001-00	1	
11	Casing seal-Viton	*	*	*	*	*	1	
12	Casing	5470-001-00	5480-001-00	5480-001-00	5490-001-00	5490-001-00	1	
13	Washer	*	*	*	*	*	4	
14	Fastener	*	*	*	*	*	4	
15	† Seal kit-Viton (original)	5470-300-91	5470-300-91	5470-300-91	5470-300-91	5470-300-91	1	
	† Seal kit-Buna-N (optional)	5470-300-90	5470-300-90	5470-300-90	5470-300-90	5470-300-90	1	
16	⊠ Pump head	5470-K8	5480-K8	5484-K8	5490-K8	5490-K8	1	

(\*) Standard hardware item, available locally.  
 (‡) Requires foot 1626-040-00.  
 (†) Includes all required seals, Ref. Nos. 7, 9, 11.  
 (⊠) Includes everything except motor. Ref. Nos. 3 thru 14.

**For Repair Parts contact dealer where pump was purchased.**

Please provide following information:

- Model number
- Serial number (if any)
- Part description and number as shown in parts list

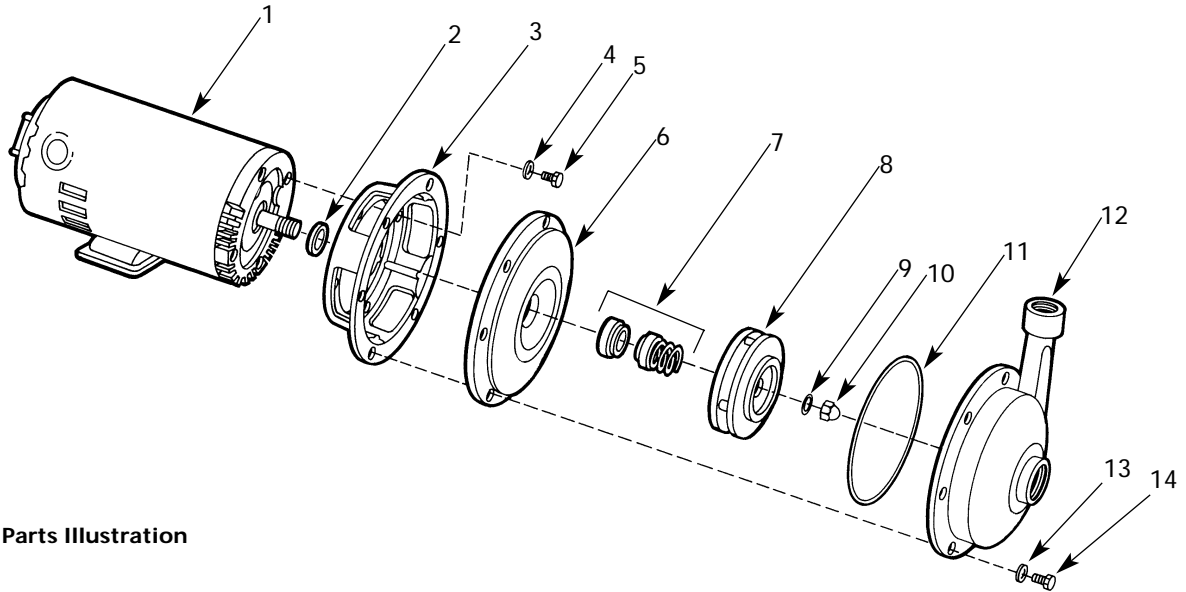

Figure 3 - Repair Parts Illustration

**Repair Parts List**

Ref. No.	Description	Part Number for Models:			Qty.	
		(1 1/2 HP) 5538-98 553A-98 5539-98 553B-98	(2 HP) 5534-98 5536-98 5535-98 5537-98	(3 HP) 5530-98 5532-98 5531-98 5533-98		
1	‡ Motor	-1 Phase ODP -3 Phase ODP -1 Phase TEFC -3 Phase TEFC	1626-012-00 1626-016-00 1626-050-00 1626-053-00	1626-024-00 1626-025-00 1626-070-00 1626-054-00	1626-026-00 1626-027-00 1626-071-00 1626-072-00	1
2	Slinger washer		1534-000-00	1534-000-00	1534-000-00	1
3	Adapter		5530-021-09	5530-021-09	5530-021-09	1
4	Washer		*	*	*	4
5	Fastener		*	*	*	4
6	Casing cover		5530-020-00	5530-020-00	5530-020-00	1
7	Shaft seal assembly-Viton		1640-161-99	1640-161-99	1640-161-99	1
8	Impeller		4903-011-02	4903-011-01	4900-011-01	1
9	Impeller seal-Viton		*	*	*	1
10	Impeller nut		1784-001-00	1784-001-00	1784-001-00	1
11	Casing seal-Viton		*	*	*	1
12	Casing		5530-001-90	5530-001-90	5530-001-90	1
13	Washer		*	*	*	6
14	Fastener		*	*	*	6
15	† Seal kit-Viton (original)		5530-300-91	5530-300-91	5530-300-91	1
	† Seal kit-Buna-N (optional)		5530-300-90	5530-300-90	5530-300-90	1
16	⊞ Pump head		5538-K8	5534-K8	5530-K8	1

(\*) Standard hardware item, available locally.  
 (‡) Requires foot 1626-040-00.  
 (†) Includes all required seals, Ref. Nos. 7, 9, 11.  
 (⊞) Includes everything except motor. Ref. Nos. 3 thru 14.

# Stamped Stainless Steel Centrifugal Pumps

## Maintenance (Continued)

pressing through from rear of casing cover.

**IMPORTANT:** Do not damage motor shaft, impeller stem, or seal cavity in casing cover as this may cause leaks.

### INSTALLATION OF NEW SEAL

**CAUTION** *The precision lapped faces of mechanical seal are easily damaged. To prevent leaks, handle replacement seal carefully. Do not touch seal mating faces.*

1. Clean seal cavity area of casing cover (Ref. No. 6). Lubricate rubber portion of seal seat (Ref. No. 7 without spring) with soapy water. Protect seal face with cardboard and press squarely into place, with polished side up. Then lay casing cover onto adapter (Ref. No. 3), and center it around motor shaft.

**IMPORTANT:** To avoid rubbing during operation, maintain gap between seal and motor shaft until assembly is complete.

2. (High *volume* models only) Clean outside of shaft stem on impeller

(Ref. No. 8). Lubricate inside rubber portion of seal head (Ref. No. 7 with spring) with soapy water. Press seal onto impeller with polished side facing away from impeller.

3. (High *head* models only) Clean motor shaft. Lubricate inside rubber portion of seal head (Ref. No. 7 with spring) with soapy water. Gently slide seal onto motor shaft with polished side facing towards motor. Be careful not to damage seal face.

**NOTE:** (High *head* models only) Impeller is designed to use no spring retainer between impeller and spring. If replacement seal is equipped with spring retainer, discard retainer.

4. Carefully screw impeller back onto motor shaft by turning clockwise. Be sure to snug-up impeller by holding motor shaft as during disassembly. Add impeller seal (Ref. No. 9), then impeller nut (Ref. No. 10) and tighten.

5. Carefully lay casing seal (Ref. No. 11) on casing cover, then put casing (Ref. No. 12) into desired position.

**NOTE:** Casing may be rotated to position discharge port at various angles.

6. Use fasteners and washers (Ref. Nos. 13 & 14) to attach casing.

**IMPORTANT:** To avoid leaks, be sure to tighten fasteners in stages to prevent casing seal from slipping and becoming pinched.

7. When assembly is complete, check for interference by spinning motor shaft by hand and listening. If rubbing is heard, *loosen* fasteners and adjust casing cover until rubbing is gone (casing may also require adjustment on high head models). If rubbing still persists, remove casing. Then check to be sure impeller is completely tightened, and not binding on shaft threads.

**CAUTION** *Seal will produce minor drag when spinning motor shaft, but rubbing anywhere else must be eliminated! Otherwise, damage to pump and/or motor may occur.*