

Please read and save this Repair Parts Manual. Read this manual and the General Operating Instructions carefully before attempting to assemble, install, operate or maintain the product described. Protect yourself and others by observing all safety information. The Safety Instructions are contained in the General Operating Instructions. Failure to comply with the safety instructions accompanying this product could result in personal injury and/or property damage! Retain instructions for future reference. AMT reserves the right to discontinue any model or change specifications at any time without incurring any obligation.

©2011 American Machine & Tool Co., Inc. of PA, A Subsidiary of The Gorman-Rupp Company, All Rights Reserved.

Periodic maintenance and inspection is required on all pumps to insure proper operation. Unit must be clear of debris and sediment. Inspect for leaks and loose bolts. Failure to do so voids warranty.

# High Head Centrifugal Pumps

## Cast Iron, Bronze, and Stainless Steel Models

Refer to pump manual 1808-634-00 for General Operating and Safety Instructions.

### DESCRIPTION

These pumps are non-self-priming units designed for use where higher heads are needed to handle liquid transfer, heating and cooling application, where no suction lift is required. All models feature high efficiency closed impellers and continuous duty, 3450 RPM, 56J frame motors. The discharge port on all models can be rotated in 90° increments to accommodate specific applications. Casing working pressure to 150 psi (1034 kPa). These are manual units, no controls are supplied. Single phase units are capacitor start and have automatic thermal protection. Check motor wiring before putting unit into operation (see motor nameplate for specific wiring diagrams). All units are for use with nonflammable, non-abrasive liquids compatible with pump component materials.

### CAST IRON UNITS

Pump construction is cast iron casing and adapter. Stainless steel impeller. Buna N type 21 mechanical shaft seal with carbon and ceramic wear faces. O-ring casing seal. Handles liquids from 40° to 180° F (4° to 82° C).

### BRONZE UNITS

Pump construction is cast bronze casing and adapter. Stainless steel impeller. Viton type 21 mechanical shaft seal with carbon and ceramic wear faces. O-ring casing seal. Handles liquids from 40° to 200° F (4° to 93° C).

### STAINLESS STEEL UNITS

Pump construction is cast 300 series stainless steel casing, adapter, and impeller. Viton type 21 mechanical shaft seal with carbon and ceramic wear faces. O-ring casing seal. Handles liquids from 40° to 200° F (4° to 93° C).

### MAINTENANCE

#### ▲ WARNING

**Make certain that the unit is disconnected from the power source before attempting to service or remove any components!**

### SHAFT SEAL REPLACEMENT

Refer to Figures 1 and 2.

### REMOVAL OF OLD SEAL

**IMPORTANT:** Always replace both seal seat (Ref. No. 5) and seal head (Ref. No. 6) to insure proper mating of components! Also, impeller seal (Ref. No. 9) should be replaced anytime impeller fastener (Ref. No. 10) has been removed.

1. Remove fasteners (Ref. No. 3) connecting casing (Ref. No. 12) to adapter (Ref. No. 4).
2. Remove casing.

#### ▲ CAUTION

**Care should be taken not to pinch or "shave" casing seal (Ref. No. 11) between adapter and casing.**

3. Use a box and/or socket wrench to remove impeller fastener. Remove impeller seal and impeller (Ref. No. 8).

**NOTE:** Motor shaft must be held in place to remove impeller. Back of the motor either has slot in shaft (use large screwdriver to hold) or has 2 flats on motor shaft (use 7/16 open end wrench to hold). Impeller and impeller fastener unscrew CCW when looking at the front of pump.

**IMPORTANT:** Care should be taken to insure that the same number of thickness of shim washers (Ref. No. 7) are replaced behind the impeller as was removed. Shim washers are located directly behind impeller and become loose as impeller is removed.

4. The seal head can now be pulled from shaft.
5. Pry seal seat from adapter.

### INSTALLATION OF NEW SEAL

#### ▲ CAUTION

**The precision lapped faces on mechanical seal are easily damaged. Handle your repair seal carefully. Do not touch polished seal faces.**

**IMPORTANT:** Be sure that shaft shoulder does not damage polished face (see figure 1).

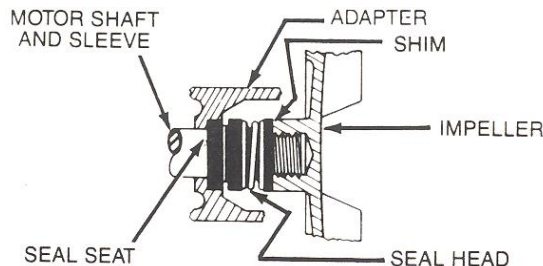

Figure 1 – Mechanical Seal

1. Thoroughly clean all surfaces of seal seat cavity in adapter.
2. Using a clean cloth, wipe shaft and shaft sleeve and make certain that they are perfectly clean.

# High Head Centrifugal Pumps

3. Wet the rubber portion of new seal seat with a light coating of soapy water. While wearing clean gloves or using a clean light rag, press seal seat squarely into adapter recess. Use cardboard washer (usually supplied with new seal), place over polished surface and use a piece of pipe or dowel rod to press in firmly but gently. Avoid scratching polished face.
4. Dispose of cardboard washer. Check again to see that polished face is free of dirt and all other foreign particles and that it has not been scratched or damaged.
5. Wet the inside rubber portion of new seal head with a light coating of soapy water. Slide head onto motor shaft with sealing surface facing seal seat (see figure 2).

**Note:** A short "run in" period may be necessary to provide completely leak-free operation.

6. Screw impeller onto shaft. Use screwdriver slot at rear of motor shaft (opposite the threaded end) to tighten impeller.

**NOTE:** It may be necessary to remove plug in motor end cap to expose slot. If removed, be sure to reinstall plug AFTER pump is completely

assembled.

7. Check if shaft turns freely by spinning impeller. If rubbing or binding is found, remove impeller and add a shim to shaft, then recheck. Repeat procedure until all rubbing is eliminated.
8. Slide impeller seal onto exposed shaft. Screw acorn nut onto shaft and tighten.
9. Place casing seal on adapter mounting flange. Attach casing using bolts being careful not to pinch or "shave" casing seal. As casing is being tightened, periodically spin impeller to check for interference with casing.

## ⚠ CAUTION

**Seal will produce minor drag when spinning motor shaft, but rubbing anywhere else must be eliminated! Otherwise, damage to pump and/or motor may occur.**

***For Repair Parts contact dealer where pump was purchased.***

Please provide following information:

-Model Number

-Serial Number (if any)

Part description and number as shown in parts list

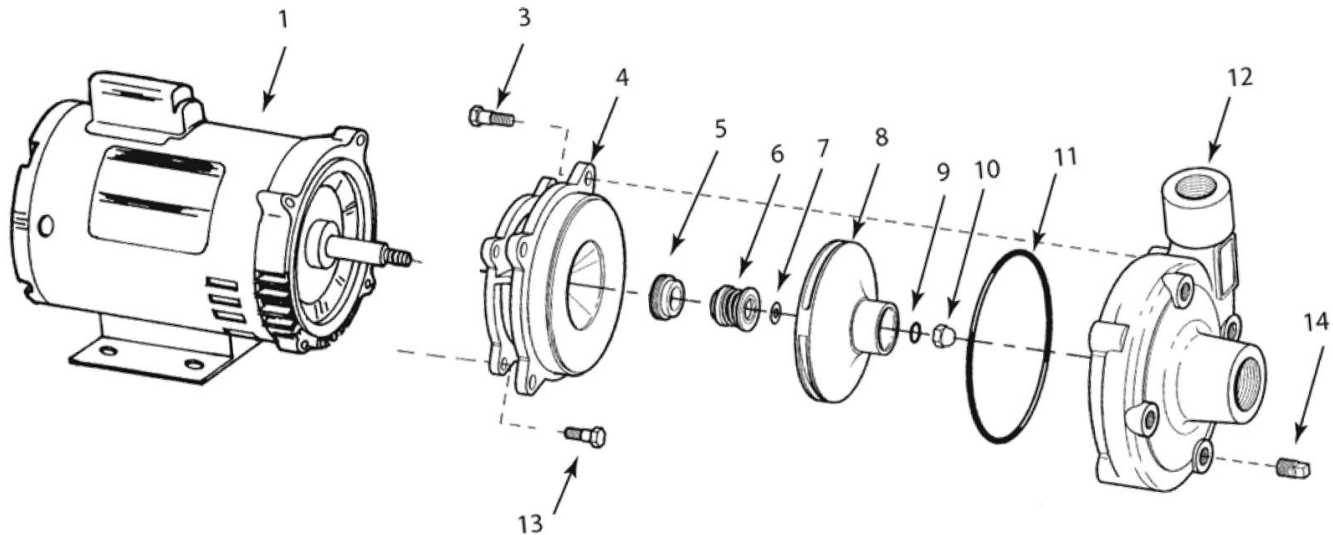

**Figure 2 – Repair Parts Illustration**

## Repair Parts List

Ref.	Description	4893 (1/2 HP)	4895 (3/4 HP)	4890 (1 HP)	4902 (1½ HP)	4904 (2 HP)	4900 (3 HP)	Qty.
		4894 (1/2 HP)	4896 (3/4 HP)	4891 (1 HP)	4903 (1½ HP)	4905 (2 HP)	4901 (3 HP)	
No.	Description	489C (3/4 HP)	-	489A (1½ HP)	490C (2 HP)	490A (3 HP)	-	Qty.
		489D (3/4 HP)	-	489B (1½ HP)	490D (2 HP)	490B (3 HP)	-	
1	Motor - 1 PH ODP	Discontinued	Discontinued	1626-011-00	1626-012-00	1626-024-00	1626-026-00	1
	Motor - 3 PH ODP	Discontinued	Discontinued	1626-015-00	1626-016-00	1626-025-00	1626-027-00	1
	Motor - 1 PH TEFC	1626-302-00	-	1626-304-00	1626-305-00	1626-306-00	-	1
	Motor - 3 PH TEFC	1626-308-00	-	1626-310-00	1626-311-00	1626-312-00	-	1
3	Fastener	*	*	*	*	*	*	4
4	Adapter - Cast Iron	4890-030-09	4890-030-09	4890-030-09	4900-030-09	4900-030-09	4900-030-09	1
	Adapter - Bronze	4890-030-97	4890-030-97	4890-030-97	4900-030-97	4900-030-97	4900-030-97	1
	Adapter - Stainless Steel	4890-031-98	4890-031-98	4890-031-98	4900-030-98	4900-030-98	4900-030-98	1
5&6	Shaft Seal Assembly - Buna N	1640-161-96	1640-161-96	1640-161-96	1640-161-96	1640-161-96	1640-161-96	1
	Shaft Seal Assembly - Viton	1640-161-97	1640-161-97	1640-161-97	1640-161-97	1640-161-97	1640-161-97	1
7	Impeller Shim Set	1806-044-90	1806-044-90	1806-044-90	1806-044-90	1806-044-90	1806-044-90	1
8	Impeller	4894-011-09	4896-011-09	4890-011-01	4903-011-09	4905-011-09	4900-011-01	1
9	Impeller Seal - Buna N	2105-036-00	2105-036-00	2105-036-00	2105-036-00	2105-036-00	2105-036-00	1
	Impeller Seal - Viton	2105-037-00	2105-037-00	2105-037-00	2105-037-00	2105-037-00	2105-037-00	1
10	Impeller Fastener	1784-001-00	1784-001-00	1784-001-00	1784-001-00	1784-001-00	1784-001-00	1
11	Casing Seal - Buna N	2221-009-00	2221-009-00	2221-009-00	2119-007-00	2119-007-00	2119-007-00	1
	Casing Seal - Viton	2221-010-00	2221-010-00	2221-010-00	2119-013-00	2119-013-00	2119-013-00	1
12	Casing - Cast Iron	4890-001-09	4890-001-09	4890-001-09	4900-001-09	4900-001-09	4900-001-09	1
	Casing - Bronze	4890-003-09	4890-003-09	4890-003-09	4900-003-09	4900-003-09	4900-003-09	1
	Casing - Stainless Steel	4890-002-09	4890-002-09	4890-002-09	4900-002-09	4900-002-09	4900-002-09	1
13	Fastener	*	*	*	*	*	*	4
14	3/8" NPT Pipe Plug	*	*	*	*	*	*	4

(\*) Standard Hardware Item, Available Locally