

Please read and save this Repair Parts Manual. Read this manual and the General Operating Instructions carefully before attempting to assemble, install, operate or maintain the product described. Protect yourself and others by observing all safety information. The Safety Instructions are contained in the General Operating Instructions. Failure to comply with the safety instructions accompanying this product could result in personal injury and/or property damage! Retain instructions for future reference.

3/4-Inch Bronze Centrifugal Pump

Refer to form 1808-634-00 for General Operating and Safety Instructions.

Description

This compact utility pump is designed for a wide range of dewatering and liquid transfer applications including marine and aquaculture. Handles liquids from 40° F to 180° F. This is a manual unit, no controls are supplied. For use with nonflammable, non-abrasive liquids compatible with pump component materials.

MODELS 4850-97 & 4851-97

These pumps self-prime (to 4½ ft. lift with pump filled) and can be used as a bilge pump for small boats or a water system pump in campers and trailers. The pump can be mounted up to a 45° angle or on a thru-hull fitting and seacock for applications requiring water aboard to be pumped overboard.

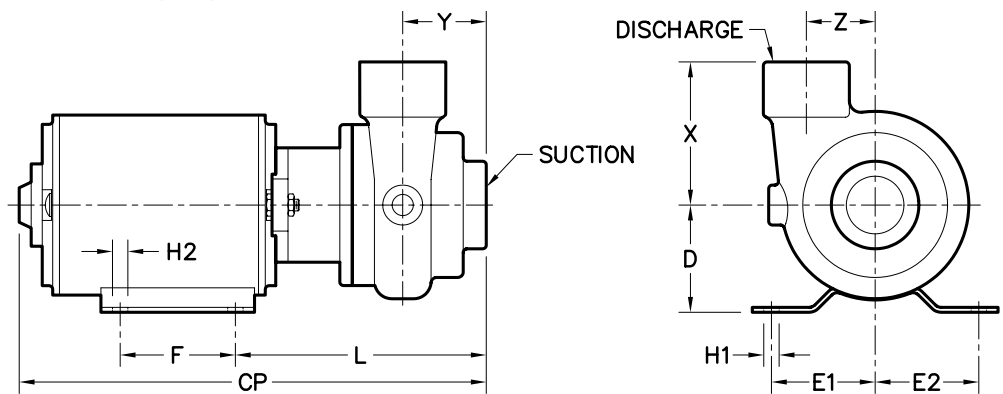

Figure 1 - Dimensions

Dimensions (Inches)

| Model | Suc.* | Dis.* | CP† | D | E1 | E2 | F | H1 | H2 | L | X | Y | Z |
|---------|-------|-------|-------|------|------|------|------|------|------|------|------|------|------|
| 4850-97 | 3/4 | 3/4 | 8.75 | 1.75 | 1.69 | 1.69 | 1.88 | 0.25 | 0.25 | 5.23 | 1.00 | 2.00 | — |
| 4851-97 | 3/4 | 3/4 | 11.63 | 2.42 | 1.75 | 1.75 | 1.69 | 0.28 | 1.00 | 5.13 | 1.00 | 2.00 | — |
| 4860-97 | 3/4 | 3/4 | 7.60 | 1.75 | 1.69 | 1.69 | 1.88 | 0.25 | 0.25 | 4.08 | 2.33 | 1.36 | 1.12 |
| 4861-97 | 3/4 | 3/4 | 10.45 | 2.42 | 1.75 | 1.75 | 1.69 | 0.28 | 1.00 | 4.00 | 2.33 | 1.36 | 1.12 |

NOTE: All dimensions have a tolerance of ± 0.13 . (*) Standard NPT (female) pipe thread. (†) This dimension may vary due to motor manufacturer's specifications.

Specifications

| Model | DRIVER HP | Enclosure | Power Supply | RPM | PUMP Type | Weight (lbs.) |
|---------|--------------|---------------------------|-------------------------|------|--------------|------------------|
| 4850-97 | 1/8 | TENV Marine Motor | 12.8 VDC | 3700 | Self-prime | 9 |
| 4851-97 | 1/12 | TEFC Type 33 Marine Motor | 115 VAC, 60 Hz, 1-phase | 3450 | Self-prime | 17 |
| 4860-97 | 1/8 | TENV Marine Motor | 12.8 VDC | 3700 | Non-prime | 7 |
| 4861-97 | 1/12 | TEFC Type 33 Marine Motor | 115 VAC, 60 Hz, 1-phase | 3450 | Non-prime | 14 |

NOTE: Driver data is subject to change without notice, see label on driver for actual specifications. (TENV) Totally Enclosed Non-Ventilated; (TEFC) Totally Enclosed Fan Cooled

Performance

| Model | GPM of Water at Total Head in Feet* | | | Max Head** |
|--------------------------------|-------------------------------------|----|-----|------------|
| | 2' | 5' | 10' | |
| 4850-97 & 4851-97 (Self-prime) | 17 | 13 | 8 | 14 ft. |
| 4860-97 & 4861-97 (Non-prime) | 10 | 4 | — | 7 |

(**) Shutoff; to convert to psi, divide by 2.31.

3/4-Inch Centrifugal Bronze Pump

General Safety Information (for 12 VDC units only)

1. GENERAL CONNECTION

INFORMATION TO A 12VDC BATTERY:

- Connect POSITIVE or PLUS(+) lead from the pump to battery first. POSITIVE lead of pump is red.
- Connect NEGATIVE or MINUS(-) lead last. NEGATIVE lead of pump is black.
- When DISCONNECTING – Disconnect NEGATIVE (-) lead first, then disconnect the POSITIVE (+) lead from the battery.

2. SPECIFIC CONNECTION INFORMATION:

- If pump is installed in car or truck and the installed car or truck battery is being used –
 - Connect POSITIVE or PLUS (+) lead from the pump to battery first. POSITIVE lead of pump is red.
 - Then connect NEGATIVE or MINUS (-) lead to a ground away from the battery, such as the metal of the car. Always connect NEGATIVE (-) last. NEGATIVE lead of pump is black.
 - When DISCONNECTING – Disconnect the NEGATIVE (-) lead from the grounded location, then disconnect the POSITIVE (+) lead from the battery.
- Pump is installed in recreational vehicle (RV), boat, motor home, etc.
 - Follow General Connection Information.
 - If possible connect NEGATIVE (-) lead of the pump to negative wiring terminal strip or other negative common point of the battery (away from the battery) if so equipped.

3. When attaching pump leads to

battery terminals be sure that the area (bilge of a boat, for instance) is adequately ventilated to prevent an explosion or fire from explosive or flammable vapors that may be present.

⚠ WARNING *Batteries emit hydrogen gas which is explosive. Avoid smoking, sparks or open flame anywhere in the vicinity of the battery.*

Explosion from battery can cause blindness. Shield eyes when working near any battery.

Batteries contain sulfuric acid. In case of contact with eyes, skin or clothing, flush immediately with large amount of water, get medical attention.

- When using leads longer than those supplied, be sure the wire is adequately sized.

⚠ WARNING *Do not add acid or electrolyte to battery being used – add only water. Consult the battery manufacturers for any additional safety instructions.*

Installation (for 12 VDC units only) WIRING & ROTATION

Connect black wire to NEGATIVE (-) terminal of battery. The orange wire with the fuse holder should run to an overload protected switch or circuit breaker, with a wire from switch or breaker to POSITIVE (+) terminal of battery. Electrical circuit must be independent of all other accessories. To prolong motor life, install pump so normal motor rotation is clockwise (See Figure 2). Use proper wire size as determined by Wire Table (See Figure 2). The proper fuse has been included in the fuse holder. Should this fuse blow, replace with the same size fuse after determining reason for blown fuse.

NOTE: No warranty consideration will be given to pumps that are returned without the properly sized fuse and fuse holder supplied with the pump.

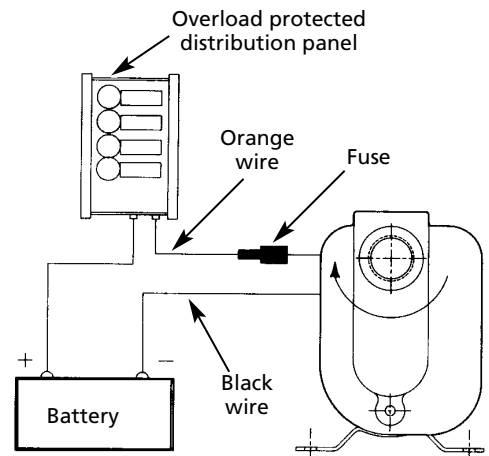

Figure 2 – Wiring Diagram

MINIMUM WIRE SIZES (FOR 12 VDC UNITS ONLY)

| Connection Length between Battery and Motor | 12V |
|---|-----|
| 1-10 ft. | #12 |
| 11-20 | 10 |
| 21-30 | 8 |

If unsure about the above information or the wiring diagrams, consult an electrician familiar with motor wiring.

AMP DRAW AND FUSE SIZES (FOR 12 VDC UNITS ONLY)

| | 12V |
|--------------------|------|
| AMP draw (approx.) | 10.5 |
| Fuse size | 15 |

Maintenance

⚠ WARNING *Disconnect from power source before servicing or inspecting pump for any reason. Failure to do so could result in fatal electrical shock!*

MECHANICAL SEAL REPLACEMENT

Refer to Figures 3, and 4

IMPORTANT: Always replace both seal seat (Ref. No. 7) and seal head (Ref. No. 6) to insure proper matching of components!

- Unthread fasteners (Ref. No. 8) and remove casing (Ref. No. 12) and casing seal (Ref. No. 11).

Models 4850-97, 4851-97, 4860-97 and 4861-97

Maintenance(Continued)

2. Unscrew fastener (Ref. No. 10) from impeller (Ref. No. 9) and remove impeller.
3. Remove fasteners (Ref. No. 2) and washers (Ref. No. 3) and remove adapter (Ref. No. 5).
4. Lay adapter face down on a flat stable surface and press seal head from adapter.
5. Pry seal seat from rear of impeller with a screwdriver or other suitable means.
6. Clean recess in adapter for seal head and recess in impeller for seal seat before inserting any new parts.
7. Inspect polished face of seal seat and head to insure they are clean and not marred.
8. Press new head into recess in adapter. A sealing compound (such as silicon or Permatex) may be used to assure a water tight fit on outside of head.
9. Press seal seat squarely into cavity in impeller (See Figure 3). If seal seat does not press squarely into cavity, it can be adjusted in place by pushing on it with a piece of pipe. Always use a piece of cardboard between pipe and seal seat to avoid scratching face of seal seat. This is a lapped surface and must be handled very carefully.
10. After seal seat is in place, check that it is clean and has not been scratched or cracked.
11. Mount adapter on motor mounting face.
12. Replace impeller providing 0.020" clearance between adapter and impeller (see figure 3), then tighten impeller fastener.
13. Place casing seal on adapter and replace casing. Replace and tighten fasteners.
14. Before operating make certain impeller turns freely and is not rubbing casing.

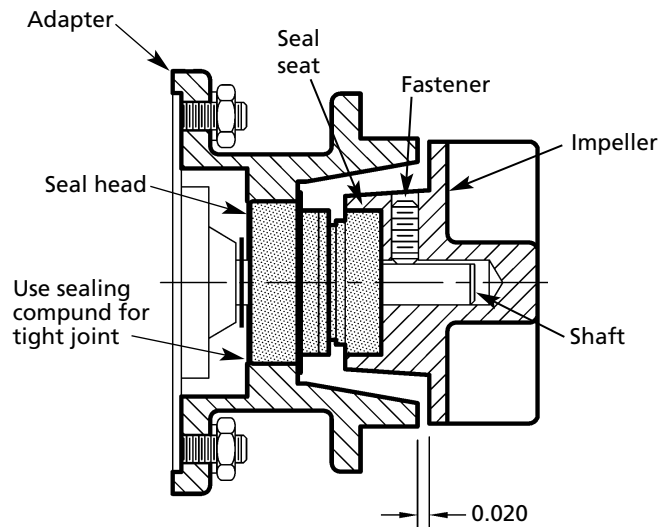

Figure 3

For Repair Parts, contact dealer where pump was purchased.

Please provide following information:

- Model number
- Serial number (if any)
- Part description and number as shown in parts list

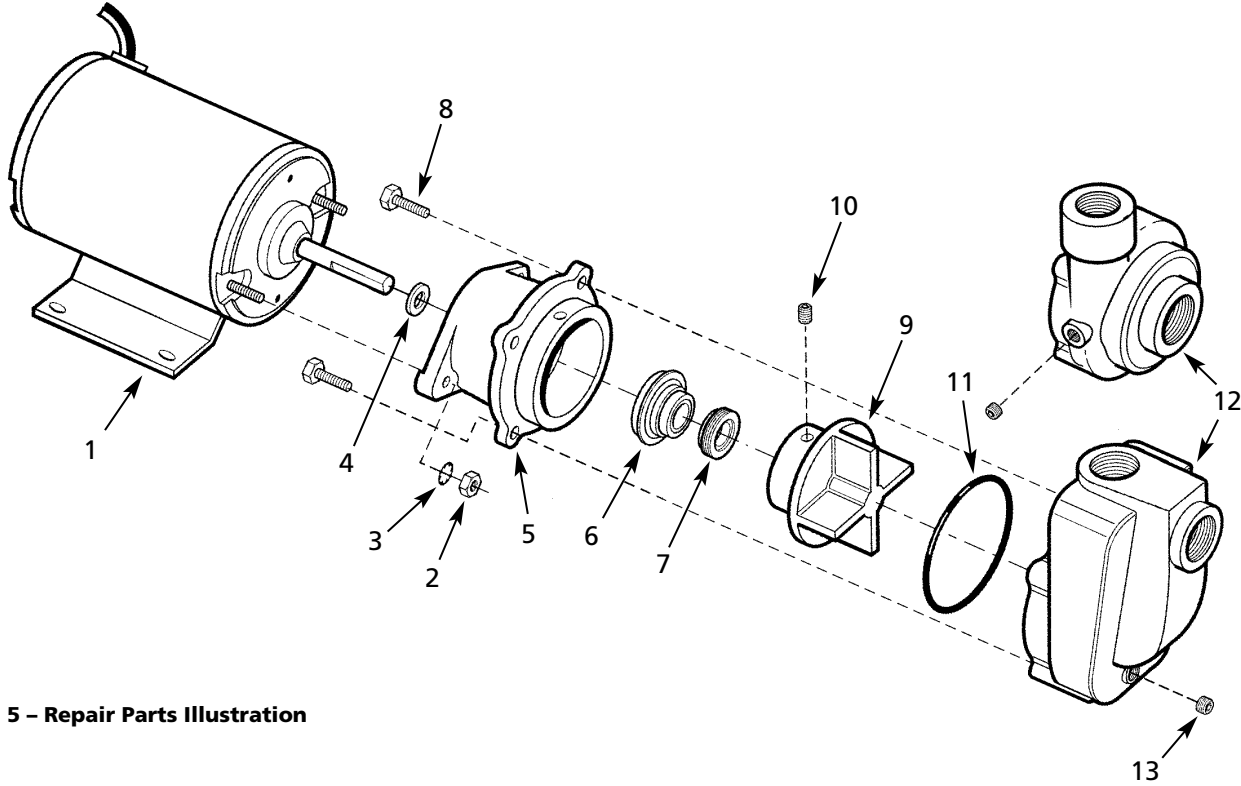

Figure 5 – Repair Parts Illustration

Repair Parts List

| Ref. No. | Description | Part Number for Models: | | | | Qty. |
|----------|-------------------------------|---------------------------------|----------------------------------|--------------------------------|---------------------------------|------|
| | | 4850-97 Self-prime 12 VDC | 4851-97 Self-prime 115 VAC | 4860-97 Non-prime 12 VDC | 4861-97 Non-prime 115 VAC | |
| 1 | Motor | 1626-023-00 | 1626-028-00 | 1626-023-00 | 1626-028-00 | 1 |
| 2 | Fastener | * | * | * | * | 2 |
| 3 | Washer | * | * | * | * | 2 |
| 4 | Flinger washer | 4850-300-00 | 4850-300-00 | 4850-300-00 | 4850-300-00 | 1 |
| 5 | Adapter | 4851-030-09 | 4851-030-09 | 4851-030-09 | 4851-030-09 | 1 |
| 6 & 7 | † Shaft seal assembly, Buna-N | 1641-051-90 | 1641-051-90 | 1641-051-90 | 1641-051-90 | 1 |
| 8 | Fastener | * | * | * | * | 4 |
| 9 | Impeller | 4850-010-09 | 4850-010-09 | 4850-010-09 | 4850-010-09 | 1 |
| 10 | Fastener | * | * | * | * | 1 |
| 11 | Casing seal, Buna-N | 1567-002-00 | 1567-002-00 | 1567-002-00 | 1567-002-00 | 1 |
| 12 | Casing | 4850-001-09 | 4850-001-09 | 4860-001-09 | 4860-001-09 | 1 |
| 13 | Pipe plug | * | * | * | * | 1 |

(*) Standard hardware item, available locally.

(†) Seal head and seat available as set only.