

Heavy Duty Industrial Coolant Pump



Model 4442-95

Model 4410-95

- **Cast Iron Casing and Column**
- **3/4" to 1-1/2" NPT Discharge Port**
- **Includes Universal Mounting Bracket**
- **Dual Volute Design Reduces Radial Load on Motor - NO BOTTOM BEARING!**
- **Maximum Temperature 200° F**
- **Maximum Flow 67 GPM**
- **Maximum Head 32 Ft.**
- **Self-Cleaning, Semi-Open Stainless Steel Impeller**
- **Available with Single or Three Phase 56C Motor**
- **1/8 to 3/4 HP Totally Enclosed Fan Cooled (TEFC) Motor, 1725 RPM**

The AMT Heavy Duty Industrial Coolant pump has been designed for a broad range of Industrial/Commercial coolant and recirculating applications. Back vanes on the impellers of models 4421-95 through 4443-95 balance pressure and thereby eliminate the need for mechanical seals. All models with extended shafts are fitted with aligning coupling between motor and shaft. Dual volute construction of models 4421-95 through 4443-95 eliminates radial thrust and therefore the need for bottom bearings. A Universal mounting bracket system is included with these pumps (see below).

AMT Mounting Brackets (Included):

Models 4410-90 & 4420-90 mounting brackets are designed to simplify the pump installation/removal process and expand the application range for each pump in the line. With the bracket system, it is no longer necessary to disassemble motor from pump end for installation and removal. Simply unfasten the brackets from the tank cover and insert or remove the complete pump. The bracket system also controls the immersion depth of each pump in the line by clamping to the pump column at the most desirable position.

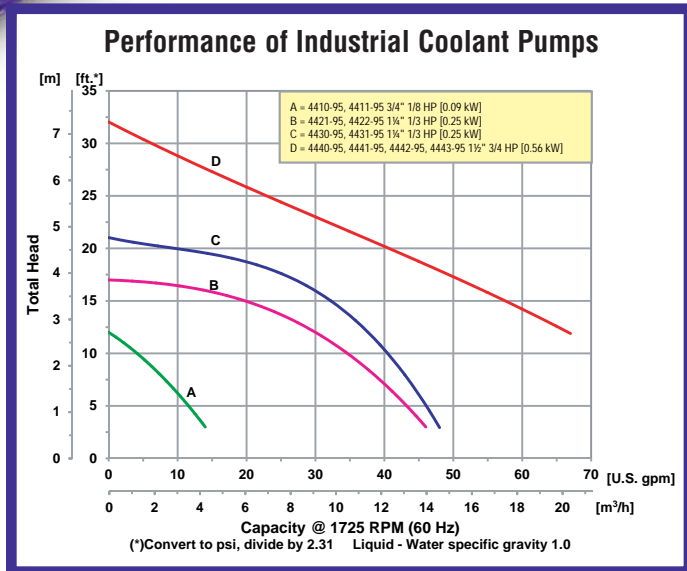

400 Spring Street • Royersford, PA 19468 USA

www.amtpump.com • 888-amt-pump (268-7867)

For use with nonflammable liquids compatible with pump component materials.

Pump Dimensional & Specification Data

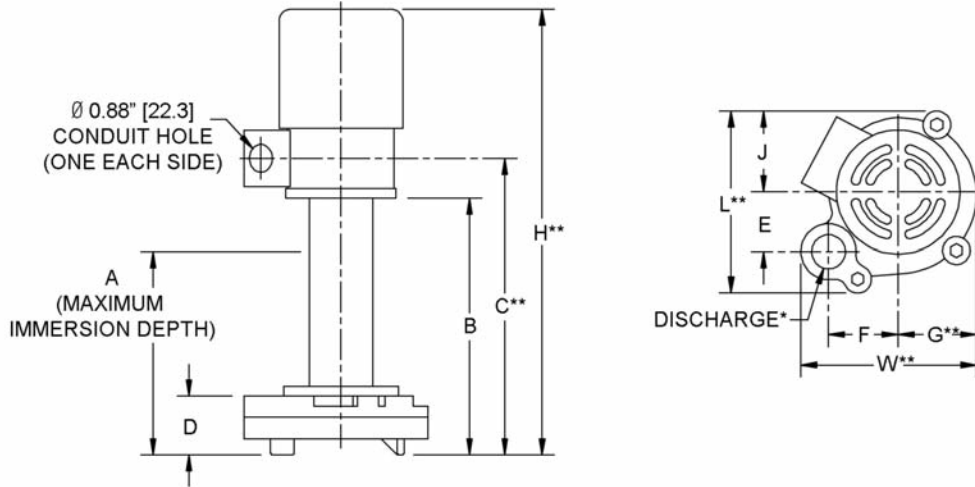

Model	Curve	HP	PH	ENC	Voltage @ 60 Hz+	Full Load Amps	DIS*	A	B	C**	D	E	F	G**	J	L**	W**	H**	Ship Wt. (Lbs.)
4410-95	A	1/8	1	TEFC	115/230	2/1	3/4	6.3 [160.0]	8.1 [205.9]	9.3 [236.2]	1.9 [48.2]	1.8 [45.7]	2.2 [55.8]	2.5 [63.5]	2.6 [66.0]	5.8 [147.3]	5.5 [139.7]	14.1 [358.1]	16
4411-95		1/8	3	TEFC	230	0.5												14.1 [358.1]	16
4421-95	B	1/3	1	TEFC	115-208/230	7/4	1-1/4	8.2 [208.3]	11.7 [297.2]	17.0 [431.8]	2.2 [55.8]	3.2 [81.3]	3.5 [88.9]	3.7 [93.9]	3.5 [88.9]	8.7 [220.9]	8.4 [213.3]	20.8 [528.3]	44
4422-95		1/3	3	TEFC	208-230/460	2/1												20.6 [523.2]	43
4430-95	C	1/3	1	TEFC	115-208/230	7/4	1-1/4	6.3 [160.0]	9.7 [246.4]	15.3 [388.6]	2.2 [55.8]	3.2 [81.3]	3.5 [88.9]	3.7 [93.9]	3.5 [88.9]	8.7 [220.9]	8.4 [213.3]	19.3 [490.2]	44
4431-95		1/3	3	TEFC	208-230/460	2/1												18.8 [477.5]	41
4440-95	D	3/4	1	TEFC	115-208/230	9/5	1-1/2	6.3 [160.0]	9.8 [248.9]	16.1 [408.9]	2.3 [58.4]	3.9 [99.0]	2.9 [73.6]	5.0 [127.0]	4.9 [124.4]	10.7 [271.7]	9.2 [233.6]	20.2 [513.0]	53
4441-95		3/4	3	TEFC	208-230/460	3/2												19.7 [500.3]	47
4442-95		3/4	1	TEFC	115-208/230	9/5												26.2 [665.4]	58
4443-95		3/4	3	TEFC	208-230/460	3/2												25.7 [652.7]	52

(*) Standard NPT (female) pipe thread.

(**) This dimension may vary due to motor manufacturer's specifications.

(+) 3-Phase models can also operate on 50 Hz (This will change Full Load Amps, Service Factor, RPM and Priming Capabilities).

NOTE: Dimensions are in inches (millimeters) and have a tolerance of $\pm 1/8"$.

NOTE: Electric supply for ALL motors must be within $\pm 10\%$ of nameplate voltage rating (e.g. 230V $\pm 10\%$ = 207 to 253).

Mounting Bracket Dimensions

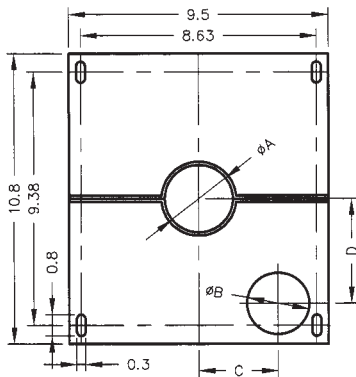

Model	A	B	C	D	Ship Wt. (Lbs.)
4410-90	2.0 [50.8]	1.1 [27.9]	1.8 [45.7]	2.1 [53.3]	8
4420-90	2.5 [63.5]	2.2 [55.8]	2.9 [73.6]	3.8 [96.5]	8

Standard Features

- Cast Iron Casing and Column
- 3/4" to 1-1/2" NPT Discharge Port
- Includes Universal Mounting Bracket
- Self-cleaning, Semi-open Stainless Steel Impeller
- Single or Three Phase 56C Motor Available
- 1/8 to 3/4 HP TEFC Motor, 1725 RPM
- Maximum Temperature 200° F
- QSP - Quick Ship Pumps

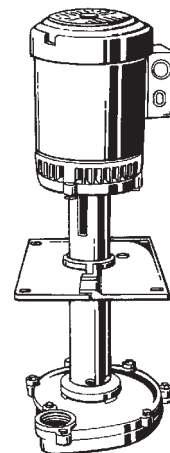

Maximum Recommended Viscosity: 500 SSU