

Please read and save these instructions. Read carefully before attempting to assemble, install, operate or maintain the product described. Protect yourself and others by observing all safety information. Failure to comply with instructions could result in personal injury and/or property damage! Retain instructions for future reference.

# Industrial / Commercial Sump Pumps

## Description

These upright sump pumps are used for drainage in industrial, residential and commercial settings. Units are completely assembled (except for float assembly) and equipped with open type impellers, TEFC motor with Square D switch, or ODP motor with Arrow-Heart switch, and grounding-type power cord. Handles liquids from 40° to 200° F. For use with non-flammable, non-abrasive liquids compatible with pump component materials.

## Specifications

### MOTOR

Model	Power Supply Required	Horsepower	Amps	Type
4000-95, 4010-97	115VAC, 60 Hz	1/3	6.8	TEFC
4020-95, 4021-98	115VAC, 60 Hz	1/2	8.5	TEFC
4001-95, 4011-97	115VAC, 60 Hz	1/3	6.8	TEFC
4022-95	115VAC, 60 Hz	1/2	8.5	TEFC
5230-98, 5231-98	115VAC, 60 Hz	1/3	6.4	ODP
5233-98, 5234-98	115VAC, 60 Hz	1/2	8.0	ODP
5236-98, 5237-98	115VAC, 60 Hz	3/4	9.8	ODP
5239-98, 523A-98	115VAC, 60 Hz	1/3	6.8	TEFC
523C-98, 523D-98	115VAC, 60 Hz	1/2	8.5	TEFC
523F-98, 523G-98	115/230VAC, 60 Hz	3/4	11.8/5.9	TEFC

(TEFC) Totally Enclosed Fan Cooled, (ODP) Open Drip Proof

**NOTE:** Driver data is subject to change without notice, see label on driver for actual specifications.

### PUMP

Model	Base	Impeller	Float	Shaft	Column	Bearing	Port Size
4000-95, 4001-95	CI	BRZ	304 SS	303 SS	BRS	BRZ	1¼"
4020-95	CI	BRZ	304	303	304 SS	BRZ	2
4022-95	CI	BRZ	304	303	403 SS	BRZ	2
4010-97, 4011-97	BRZ	BRZ	304	303	BRS	BRZ	1¼
5230-98 thru 523G-98	304 SS	304 SS	304	303	304 SS	CBN	1½
4021-98	316 SS	316 SS	304	303	304	CBN	2

(CI) Cast Iron, (BRS) Brass, (BRZ) Bronze, (SS) Stainless Steel, (CBN) Carbon

## Dimensions and Performance

Model	Height	Width	Weight	GPM of Water at Total Head in Feet				Max. Head*
				5'	10'	15'	20'	
4000-95, 4010-97	35"	10"	39, 42 lbs.	49 gpm	37	22	3	20.5 ft.
4001-95, 4011-97	47	10	47, 49					
4020-95, 4021-98	41	12	49, 52	103	72	39	3	20.5
4022-95	53	12	55					
5230-98, 5231-98	40, 52	11	28, 30	54	44	30	—	20
5239-98, 523A-98	38, 50	11	34, 36					
5233-98, 5234-98	40, 52	11	31, 33	65	58	49	35	25
523C-98, 523D-98	38, 50	11	37, 39					
5236-98, 5237-98	40, 52	11	34, 36	83	76	67	56	30
523F-98, 523G-98	39, 51	11	40, 42					

(\*) Shut-off; to convert to psi, divide by 2.31.

## Unpacking

When unpacking the unit, inspect for any damage that may have occurred during transit. Check for loose, missing or damaged parts.

## General Safety Information

1. Know the pump application, limitations, and potential hazards.

**⚠ WARNING** Do not use to pump flammable or explosive fluids such as gasoline, fuel oil, kerosene, etc. Do not use in explosive atmospheres. Pump should only be used with liquids compatible with pump component materials. Failure to follow this warning can result in personal injury and/or property damage.

2. Make certain that the power source conforms to the requirements of your equipment (115 vac.)
3. Provide adequate protection and guarding around moving parts.
4. Disconnect power before servicing. If the power disconnect is out of sight, lock in the open position and tag it to prevent unexpected application of power. Failure to do so could result in fatal electrical shock!
5. Release all pressure within the system before servicing any component.
6. Drain all liquids from the system before servicing.
7. Secure the discharge line before starting the pump. An unsecured discharge line will whip, possibly causing personal injury and/or property damage.
8. Check hoses for weak or worn condition before each use, making certain that all connections are secure.

# Industrial / Commercial Sump Pumps

## General Safety Information (Continued)

9. Periodically inspect pump and system components. Perform routine maintenance as required (See Maintenance section).
10. Provide a means of pressure relief for pumps whose discharge line can be shut off or obstructed.
11. Personal Safety:
  - a. Keep work area clean, uncluttered and properly lighted - replace all unused tools and equipment.
  - b. Keep visitors at a safe distance from the work area.
  - c. Make workshop child proof - with padlocks, master switches, and by removing starter keys.
12. Do not handle the pump with wet hands or when standing in water as fatal electrical shock could occur. Disconnect main power before handling unit for any reason.
13. Do not touch an operating motor. Modern motors are designed to operate at high temperatures.
14. It is strongly recommended that this unit is plugged into a Ground Fault Circuit Interrupter (GFCI). Consult a local electrician for installation and availability.
15. All wiring should be performed by a qualified electrician.
16. When wiring an electrically driven pump, follow all electrical and safety codes, as well as the most recent United States National Electrical Code (NEC) and the Occupational Safety and Health Act (OSHA).

**⚠ WARNING** *Risk of Electric Shock! Never connect the green (or green and yellow) wire to a live terminal!*

17. This equipment is only for use on 115 volt (single phase) and is equipped with an approved 3-conductor cord and 3-prong,

grounding-type plug (See Figure 1). To reduce the risk of electric shock, the motor must be securely and adequately grounded. This can be accomplished by either: 1) Inserting plug directly into a properly installed and grounded 3-prong grounding-type receptacle (See Figure 1); 2) Permanently wiring the unit with a grounded, metal raceway system; 3) Using a separate ground wire connected to the bare metal of the frame; or 4) Other suitable means.

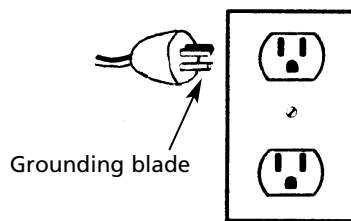

**Figure 1 - Grounding**

Where a 2-prong wall receptacle is encountered, it must be replaced with a properly grounded 3-prong receptacle installed in accordance with the National Electrical Code and local codes and ordinances. To ensure a proper ground, the grounding means must be tested by a qualified electrician.

Use only 3-wire extension cords that have 3-prong, grounding-type plug, and 3-pole receptacles that accept the equipment plug.

18. Use wire of adequate size to minimize voltage drop at the motor.
19. Protect electrical cord from sharp objects, hot surfaces, oil, and chemicals. Avoid kinking the cord. Replace or repair damaged or worn cords immediately.
20. Keep fingers and foreign objects away from ventilation and other openings. Do not insert any objects into the motor.

**⚠ WARNING** *The pump motor is equipped with an automatic resetting thermal protector and may restart unexpectedly. Protector tripping is an indication of motor overloading as a result of operating the pump at low heads (low discharge restriction), excessively high or low voltage, inadequate wiring, incorrect motor connections, or a defective motor or pump.*

## Preinstallation

### SUMP PIT AND GENERAL INFORMATION

This unit can be installed in a pit with a minimum diameter of 18" and a depth of 24". (Pit dimensions less than these will cause rapid cycling and shortened pump life.) A pit may be constructed of tile, concrete, steel or plastic. Check local codes for approved materials. The pit should have a hard bottom. Do not place pump directly on clay, earth or sand surface. Make sure there are no small stones, gravel, sand, dirt, silt, etc. that may clog or damage the pump and/or seal and cause pump failure. If there are stones or gravel, clean these out as deep as possible by hand; do not damage or move any drain tiles below. Fill the pit to the same level as before with 3/4" to 1" stones and place either a round or square patio block (slightly smaller than pit, e.g. 18" diameter pit should have a 14" round patio block). The patio block will form a solid foundation for the pump and still allow seepage water to enter the pit from below. Test pump for proper operation (See Operation) before installing pit cover. A pit cover will prevent debris from possibly clogging or damaging the pump, it will also prevent persons from falling in and causing injury.

### NEW SUMP

If you are installing a new sump:

1. Locate pump approximately 6" from basement wall in lowest point of basement floor.

## Models 4000 thru 4022 & 5230 thru 523G

### Preinstallation (Continued)

2. With chalk, mark out diameter on floor.
  3. Cut through floor with masonry drill or other concrete cutting tool and excavate below the floor to required depth.
  4. Level bottom and set sump tile in place. Tie in any sub-floor drains. Backfill and mortar tile or sump pit in place. The top should be flush with floor for surface drainage.
  5. It is recommended that bottom of tile be provided with a concrete base. However, a concrete block or bricks may be used to provide a support for the sump pump.
3. Protect pump from extreme heat, cold, and dampness. This unit is not waterproof and is not intended to be used in showers, saunas, or other potentially wet locations. The motor is designed to be used in a clean dry location with access to an adequate supply of cooling air. Ambient temperature around the motor should not exceed 104°F (40°C). For outdoor installations motor must be protected by a cover that does not block airflow to and around the motor. This unit is not weatherproof nor is it able to be submersed in water, or any other liquid.
  4. Connect discharge piping and run it to nearest sewer or surface outlet. Sump pumps can be piped to discharge into the house drainage system, to a dry well, splash block, or to a storm drain depending on local plumbing codes. The discharge piping should be as short as possible to reduce pipe friction losses. It is recommended that the discharge pipe diameter should be equal to or larger than the discharge size of the pump. Smaller pipe diameters will restrict the capacity of the pump and reduce performance. These sump pumps are provided with an NPT discharge connection. Assure airtight pipe connections with the use of a pipe joint sealant.

### Installation

**⚠ WARNING** *In installations where property damage might result because of an inoperative pump due to power outages, discharge line freezing, or any other reason, backup system(s) should be used.*

*These pumps should never be used in hazardous or explosive locations, nor in swimming pool applications.*

### PUMP LOCATIONS & CONNECTIONS

1. Pump should be located and should rest on a level solid foundation. Do not suspend pump by means of the discharge pipe or power cord. Keep pump inlet clear. Do not install pump directly on clay, earth or sand surfaces. Clean sump pit of small stones, gravel, sand, dirt, silt, etc., which could clog or damage pump, or seal, and cause pump failure. Keep pump inlet clear.
  2. Locate pump in center of pit so that pump housing and any float control will not come in contact with side of pit and create operational problems. Installation should be with motor and all electrical components above the top grade level of the sump. This motor is not submersible.
6. In installations where the piping is long, the vertical discharge is above 7 or 8 feet, or a small sump has been provided, use of a check valve is recommended to prevent backflow of water into the sump. Where a check valve is used, drill a relief hole (1/8" or 3/16" diameter) in the discharge pipe. This hole should be located below the floor line between the pump discharge and the check valve. Unless such a relief hole is provided, the pump could "air lock" and will not pump water even though it will run.
  7. It is strongly recommended that this pump motor be electrically connected to a ground fault interrupter. Consult your local electrician for availability and installation.
  8. Power Supply: Pump is designed for 115V, 60 Hz operation and requires a circuit of 15 amperes or more capacity. Wire unit on a separate line (power). Pump is supplied with a 3-wire cord set with ground-type plug for use in a 3-wire, grounded outlet. Three-wire extension cord, of at least 14 AWG size is suggested, with larger sizes for runs over 25 feet. For safety, pump should always be electrically grounded to a suitable electrical ground such as a grounded water pipe or a properly grounded metallic raceway, or ground wire system.  
**DO NOT CUT OFF THE ROUND GROUNDING PRONG.** Cutting cord or plug will void warranty. Do not bend, kink or cut power cord.

# Industrial / Commercial Sump Pumps

## Installation (Continued)

Protect cord from sharp objects, hot surfaces, oil & chemicals.

Replace damaged cord.

### 9. Float rod stop setting:

#### a. ON high

water level stop setting: with the switch arm in the OFF position, slide float rod assembly up, until float is at desired high water level position.

#### b. Position lower rod stop "A":

it must trip the switch arm into the ON position when float reaches high water mark.

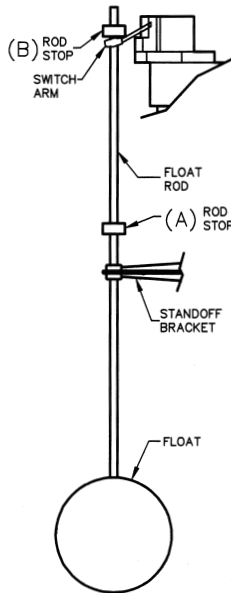

**NOTE:** Care must be taken to ensure that rod stop "A" trips the switch arm before the float hits standoff bracket. Pump will not turn ON if float makes contact against standoff bracket before stop "A" activates motor switch.

c. OFF low water setting: with switch arm in ON position, slide float rod assembly down until float is at desired low water level.

d. Position upper rod stop "B" so that it trips switch arm into OFF position when float reaches low water level.

**NOTE:** Care must be taken to ensure that upper rod stop "B" trips the switch arm before lower rod stop "A" contacts standoff bracket. Pump will not turn off if lower rod stop "A" contacts the bracket before upper rod stop "B" activates motor switch.

e. After setting all stops as described above, the sump should be filled with water. The pump should be checked for correct operation and desired ON/OFF water levels.

**⚠ WARNING** *Disconnect the power supply before attempting any servicing or adjustments to the pump.*

10. Do not allow the cord to interfere with the float control motion or to drape over the pump motor. With electrician's tape, secure the cord to the discharge pipe. This will provide protection for the cord and make a neat installation.

11. Install any auxiliary components (e.g. back-up pumps, warning systems, timer, etc.).

12. After all piping and controls have been installed, connect the pump cord cap to the electrical outlet and run water into the sump to test the pump.

13. Unit is ready for operation.

## Operation

**⚠ WARNING** *Do not touch sump pump, pump motor, water, or discharge piping when the pump is connected to electrical power. Do not handle a pump or pump motor with wet hands or when standing on wet or damp surface, or in water. Never touch the sump pump or discharge piping when unit is operating or fails to operate. Always disconnect the pump cord (power) before handling. Do not attempt to operate pump without water! Bearings could be damaged if pump is run dry.*

1. Plug unit into 115V outlet.
2. Fill the sump with water to the normal turn-on level and allow pump to remove water to normal control turn-off point.
3. If necessary readjust the cut-in/cut-out differential. See Step 9 under Installation for guidance.
4. The float must not touch pit walls or discharge pipe and must be able to move freely.
5. Install a sump cover. A cover will prevent matter from falling into sump, prevent odors, and guard against accidental injury.
6. While the unit is draining the sump, verify that the discharge piping is

carrying the water to a point several feet away from the foundation.

## Maintenance

**⚠ WARNING** *Make certain that the pump is unplugged before attempting to service or remove any component. This is a difficult pump to repair, therefore only qualified electricians or service personnel should attempt to repair this unit. Improper repair and/or assembly can cause an electrical shock hazard.*

1. Pump and motor bearings require NO lubrication.
2. Pump should be checked for proper operation weekly or monthly by filling the sump pit with water and watching the operation of the pump, the on and off locks, etc. If anything has changed since the pump was new, the pump should be removed from the pit, examined, and repaired.
3. Inlet should be kept clean and free of all foreign objects and periodically inspected. Sump pit should be kept free of small stones, gravel, sand, dirt, silt, etc. These items can clog and/or damage pump and pump bearings, eventually causing pump failure.

## Models 4000 thru 4022 & 5230 thru 523G

### Troubleshooting Chart

Symptom	Possible Cause(s)	Corrective Action
Pump won't start or run	<ol style="list-style-type: none"> <li>1. Water level too low</li> <li>2. Blown fuse</li> <li>3. Low line voltage</li> <li>4. Defective motor</li> <li>5. Defective float switch</li> <li>6. Impeller clogged or jammed (pump filled with debris)</li> <li>7. Float water-logged</li> <li>8. Float touching or jammed up against side of pit</li> </ol>	<ol style="list-style-type: none"> <li>1. Pump will not turn on unless float pushes collar to activate switch</li> <li>2. If blown, replace with fuse of proper size</li> <li>3. If voltage under recommended minimum, check size of wiring from main switch on property. If OK, contact power company</li> <li>4. Replace motor</li> <li>5. Replace switch</li> <li>6. Disassemble and clean out. If impeller won't turn, remove housing and locate source of binding</li> <li>7. Replace float</li> <li>8. Reposition pump, move away from side of pit</li> </ol>
Pump starts and stops too often	<ol style="list-style-type: none"> <li>1. Backflow of water from piping</li> <li>2. Improper positioning of float rod collars</li> <li>3. Long extension cord</li> <li>4. Low line voltage</li> <li>5. Very low discharge head or pit too small</li> </ol>	<ol style="list-style-type: none"> <li>1. Install check-valve</li> <li>2. Reposition</li> <li>3. Shorten extension cord</li> <li>4. Check for proper wire size. If OK, call power company</li> <li>5. Increase discharge head or restrict discharge by use of gate valve (1/2 open), make pit larger</li> </ol>
Pump won't shut off	<ol style="list-style-type: none"> <li>1. Defective switch</li> <li>2. Restricted discharge (rag or obstacle in piping)</li> <li>3. Float rod jammed or defective</li> <li>4. Float touching or jammed up against side of pit</li> </ol>	<ol style="list-style-type: none"> <li>1. Replace switch</li> <li>2. Remove pump and clean pump and piping</li> <li>3. Repair or replace</li> <li>4. Reposition pump, move away from side of pit</li> </ol>
Pump operates, but delivers little or no water	<ol style="list-style-type: none"> <li>1. Low line voltage</li> <li>2. Debris caught in impeller</li> <li>3. Worn or defective pump parts or plugged impeller</li> <li>4. Pump air locked</li> </ol>	<ol style="list-style-type: none"> <li>1. If voltage under recommended minimum, check size of wiring from main switch on property. If OK, contact power company</li> <li>2. Remove and clean out</li> <li>3. Replace worn parts or entire pump. Clean parts if required</li> <li>4. Drill 1/8" hole in discharge piping between pump and check valve</li> </ol>

**For Replacement Parts, contact dealer where pump was purchased.**

Please provide following information:

- Model number
- Serial number (if any)
- Part description and number as shown in parts list

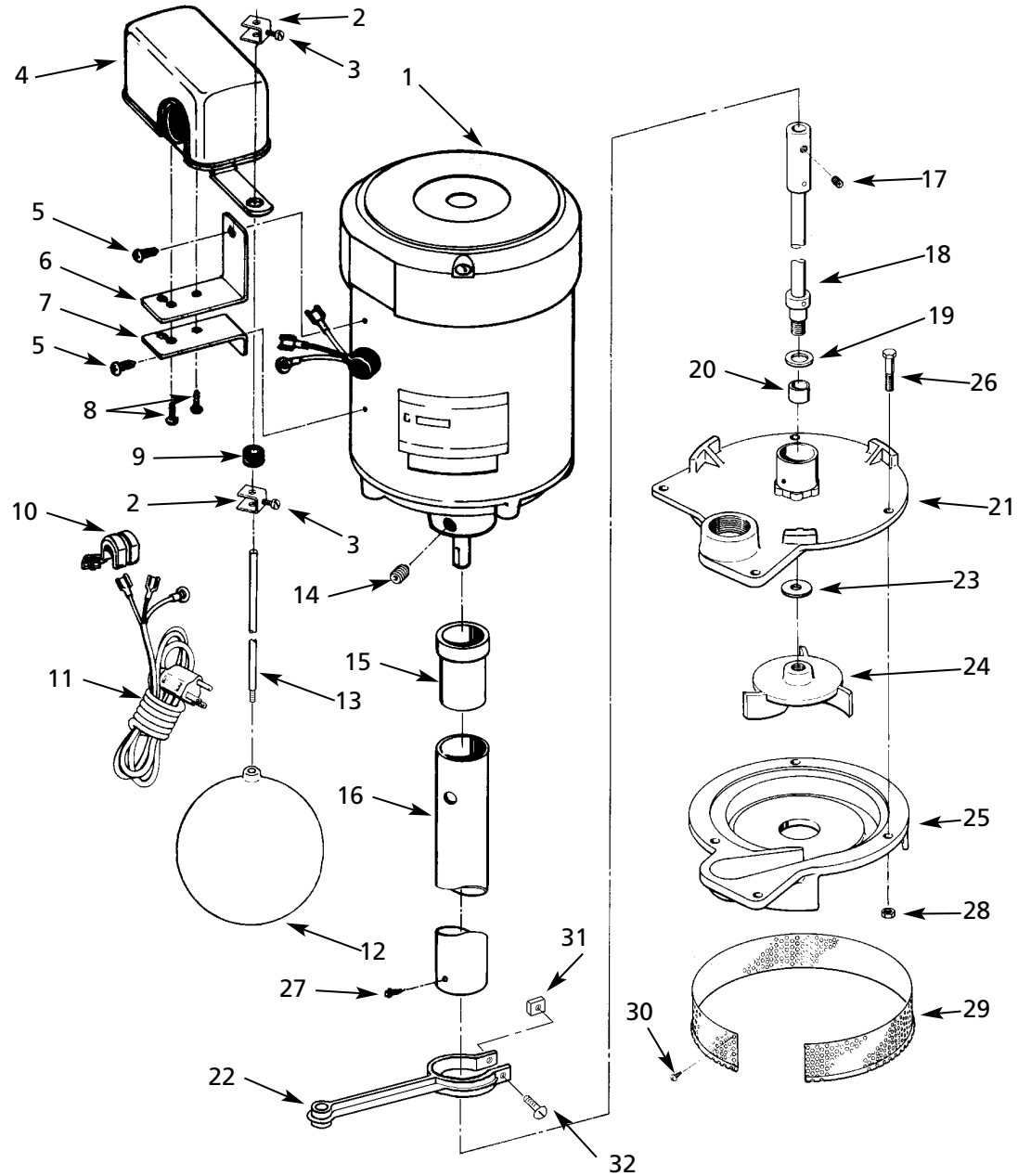

Figure 2 — Replacement Parts Illustration

# Replacement Parts List

Ref. No.	Description	Part Number for Models:				Qty.
		4000-95 24" Cast Iron	4010-97 24" Cast Bronze	4001-95 36" Cast Iron	4011-97 36" Cast Bronze	
1	Motor	1626-057-00	1626-057-00	1626-057-00	1626-057-00	1
2	Float rod stop	2178-004-00	2178-004-00	2178-004-00	2178-004-00	2
3	Float rod stop screw (18-8 stainless)	1707-001-00	1707-001-00	1707-001-00	1707-001-00	2
4	Switch	5460-000-00	5460-000-00	5460-000-00	5460-000-00	1
5	#10 x 1/4" Phillips sheet metal screw	*	*	*	*	2
6	Top switch bracket	2191-005-00	2191-005-00	2191-005-00	2191-005-00	1
7	Bottom switch bracket	2191-004-00	2191-004-00	2191-004-00	2191-004-00	1
8	#8-32 UNC x 3/8" round hd machine screw	*	*	*	*	2
9	Switch grommet	2193-000-00	2193-000-00	2193-000-00	2193-000-00	1
10	Strain relief bushing	2191-007-00	2191-007-00	2191-007-00	2191-007-00	1
11	Line cord	1639-077-00	1639-077-00	1639-077-00	1639-077-00	1
12	Float	5239-107-00	5239-107-00	5239-107-00	5239-107-00	1
13	Float rod	5230-104-00	5230-104-00	5231-104-00	5231-104-00	1
14	1/4"-20 UNC x 1/4" set screw	*	*	*	*	3
15	Tube insert	2180-001-00	2180-001-00	2180-001-09	2180-001-09	1
16	Tube column	2192-000-00	2192-000-00	2192-001-00	2192-001-00	1
17	Shaft set screw (303 stainless)	1713-004-00	1713-004-00	1713-004-00	1713-004-00	3
18	Shaft assembly (includes #17)	4000-140-90	4000-140-90	4001-140-90	4001-140-90	1
19	Thrust washer	1237-000-00	1237-000-00	1237-000-00	1237-000-00	1
20	Bearing	2196-000-00	2196-000-00	2196-000-00	2196-000-00	1
21	Top cover plate (includes #20)	2187-000-01	2197-000-01	2187-001-09	2197-002-09	1
22	Standoff bracket	5230-102-00	5230-102-00	5230-102-00	5230-102-00	1
23	Impeller shims	1658-000-90	1658-000-90	1658-000-90	1658-000-90	1
24	Impeller	2199-000-01	2199-000-01	2199-000-01	2199-000-01	1
25	Base	2188-000-01	2198-000-01	2188-000-01	2198-000-01	1
26	1/4"-20 UNC x 7/8" cap screw (18-8 stainless)	1718-001-00	1718-001-00	1718-001-00	1718-001-00	4
27	#8-32 UNC x 1/4" slotted hex hd self tapping screw (18-8 stainless)	1699-003-00	1699-003-00	1699-003-00	1699-003-00	3
28	1/4"-20 UNC hex nut (18-8 stainless)	1774-000-00	1774-000-00	1774-000-00	1774-000-00	4
29	Sediment screen	2189-000-00	2189-000-00	2189-000-00	2189-000-00	1
30	Sediment screen fastener	1697-000-00	1697-000-00	1697-000-00	1697-000-00	4
31	Machine nut	*	*	*	*	1
32	Machine screw	*	*	*	*	1

(\*) Standard hardware item, available locally.

**For Replacement Parts, contact dealer where pump was purchased.**

Please provide following information:

- Model number
- Serial number (if any)
- Part descriptions and number as shown in parts list

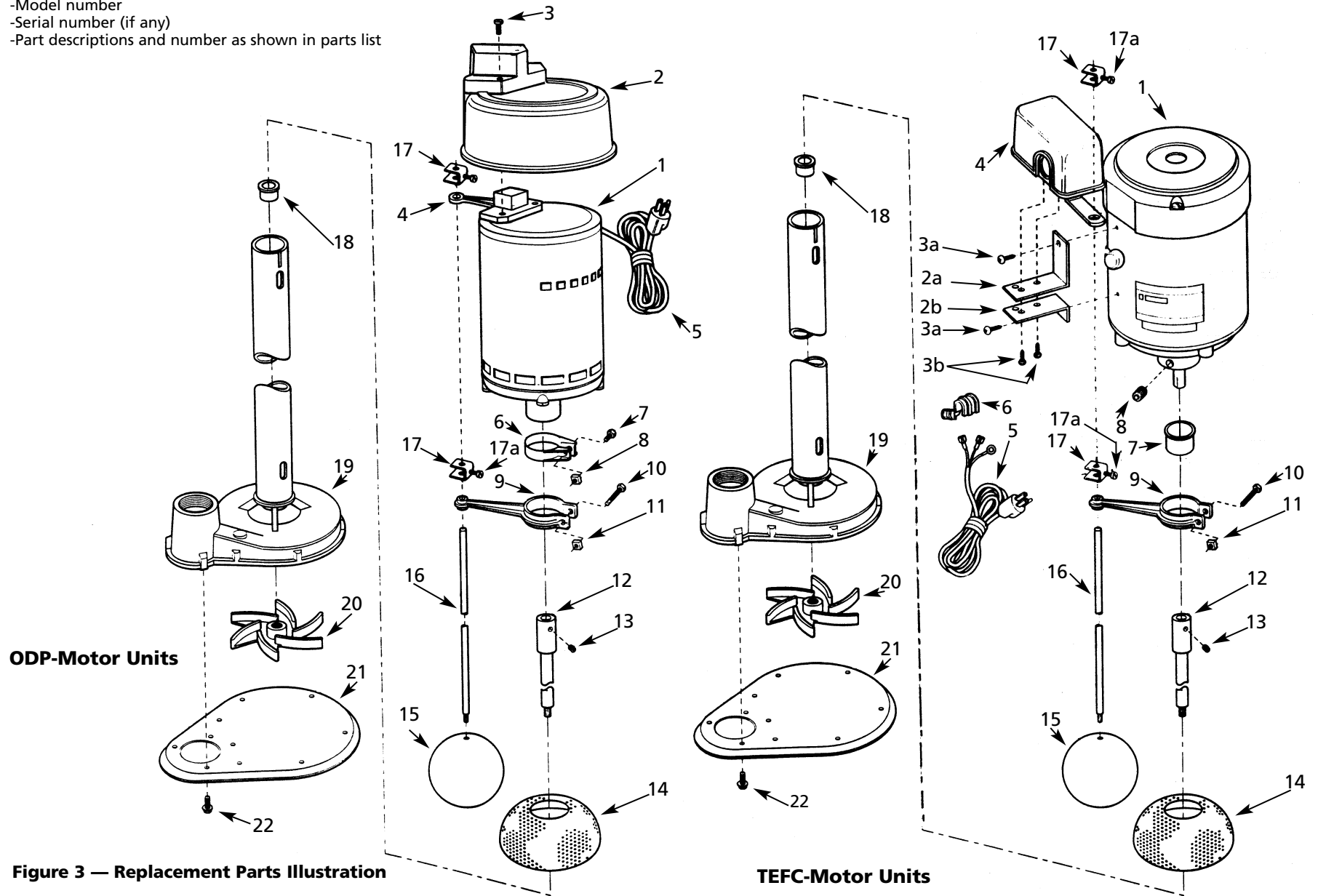

Figure 3 — Replacement Parts Illustration

TEFC-Motor Units

# Replacement Parts List

Ref. No.	Description	Part Number for Models:						Qty.
		5230-98 24" 1/3HP ODP	5231-98 36" 1/3HP ODP	5233-98 24" 1/2HP ODP	5234-98 36" 1/2HP ODP	5236-98 24" 3/4HP ODP	5237-98 36" 3/4HP ODP	
1	Motor	1626-059-00	1626-059-00	1626-060-00	1626-060-00	1626-061-00	1626-061-00	1
2	Drip Cover	5230-108-00	5230-108-00	5230-108-00	5230-108-00	5230-108-00	5230-108-00	1
3	#12-24 UNC x 1" mach screw	*	*	*	*	*	*	3
4	Switch	5230-350-00	5230-350-00	5230-350-00	5230-350-00	5230-350-00	5230-350-00	1
5	Power Cord	5230-351-00	5230-351-00	5230-351-00	5230-351-00	5230-351-00	5230-351-00	1
6	Column clamp	5230-100-00	5230-100-00	5230-100-00	5230-100-00	5230-100-00	5230-100-00	1
7	1/4"-20 UNC x 3/4" hex cap screw	*	*	*	*	*	*	1
8	1/4"-20 UNC square nut	*	*	*	*	*	*	1
9	Standoff bracket	5230-101-00	5230-101-00	5230-101-00	5230-101-00	5230-101-00	5230-101-00	1
10	#10-24 UNC x 1-3/4" mach screw	*	*	*	*	*	*	1
11	#10-24 UNC square nut	*	*	*	*	*	*	1
12	Shaft assembly (includes #13)	5230-140-90	5231-140-90	5230-140-90	5231-140-90	5230-140-90	5231-140-90	1
13	1/4"-20 UNC x 3/8" set screw	*	*	*	*	*	*	3
14	Screen	5230-040-00	5230-040-00	5230-040-00	5230-040-00	5230-040-00	5230-040-00	1
15	Float	5239-107-00	5239-107-00	5239-107-00	5239-107-00	5239-107-00	5239-107-00	1
16	Float rod	5230-104-00	5231-104-00	5230-104-00	5231-104-00	5230-104-00	5231-104-00	1
17	Rod stop	2178-004-00	2178-004-00	2178-004-00	2178-004-00	2178-004-00	2178-004-00	2
17a	Rod stop screw	1707-001-00	1707-001-00	1707-001-00	1707-001-00	1707-001-00	1707-001-00	2
18	Shaft bearing	2196-004-00	2196-004-00	2196-004-00	2196-004-00	2196-004-00	2196-004-00	1
19	Volute/column (includes #18)	5230-150-98	5231-150-98	5230-150-98	5231-150-98	5230-150-98	5231-150-98	1
20	Impeller	5230-012-09	5230-012-09	5230-011-09	5230-011-09	5230-010-09	5230-010-09	1
21	Base plate	5230-060-00	5230-060-00	5230-060-00	5230-060-00	5230-060-00	5230-060-00	1
22	#10 x 1/2" SS self tapping screw	1707-008-00	1707-008-00	1707-008-00	1707-008-00	1707-008-00	1707-008-00	10

(\*) Standard hardware item, available locally.

## Replacement Parts List (Continued)

Ref. No.	Description	Part Number for Models:						Qty.
		5239-98 24" 1/3 HP TEFC	523A-98 36" 1/3HP TEFC	523C-98 24" 1/2HP TEFC	523D-98 36" 1/2HP TEFC	523F-98 24" 3/4HP TEFC	523G-98 36" 3/4HP TEFC	
1	Motor	1626-057-00	1626-057-00	1626-058-00	1626-058-00	1639-101-00	1639-101-00	1
2 a	Top switch bracket	2191-005-00	2191-005-00	2191-005-00	2191-005-00	2191-005-00	2191-005-00	1
2 b	Bottom switch bracket	2191-004-00	2191-004-00	2191-004-00	2191-004-00	2191-004-00	2191-004-00	1
3 a	#8-32 UNC x 3/8" rd hd mach screw	*	*	*	*	*	*	2
3 b	#10 x 1/4" sheet metal screw	*	*	*	*	*	*	2
4	Switch	5460-000-00	5460-000-00	5460-000-00	5460-000-00	5460-000-00	5460-000-00	1
5	Power Cord	1639-077-00	1639-077-00	1639-077-00	1639-077-00	1639-077-00	1639-077-00	1
6	Strain relief bushing	2191-007-00	2191-007-00	2191-007-00	2191-007-00	2191-007-00	2191-007-00	1
7	Tube insert	5239-030-00	5239-030-00	5239-030-00	5239-030-00	5239-030-00	5239-030-00	1
8	M8 x 0.8 x 10 mm soc hd cap screw	*	*	*	*	*	*	3
9	Standoff bracket	5230-102-00	5230-102-00	5230-102-00	5230-102-00	5230-102-00	5230-102-00	1
10	#10-24 UNC x 1-3/4" mach screw	*	*	*	*	*	*	1
11	#10-24 UNC square nut	*	*	*	*	*	*	1
12	Shaft assembly (includes #13)	5230-140-90	5231-140-90	5230-140-90	5231-140-90	5230-140-90	5231-140-90	1
13	1/4"-20 UNC x 3/8" set screw	*	*	*	*	*	*	3
14	Screen	5230-040-00	5230-040-00	5230-040-00	5230-040-00	5230-040-00	5230-040-00	1
15	Float	5239-107-00	5239-107-00	5239-107-00	5239-107-00	5239-107-00	5239-107-00	1
16	Float rod	5230-104-00	5231-104-00	5230-104-00	5231-104-00	5230-104-00	5231-104-00	1
17	Rod stop	2178-004-00	2178-004-00	2178-004-00	2178-004-00	2178-004-00	2178-004-00	2
17 a	Rod stop screw	1707-001-00	1707-001-00	1707-001-00	1707-001-00	1707-001-00	1707-001-00	2
18	Shaft bearing	2196-004-00	2196-004-00	2196-004-00	2196-004-00	2196-004-00	2196-004-00	1
19	Volute/column (includes #18)	5239-150-98	523A-150-98	5239-150-98	523A-150-98	5239-150-98	523A-150-98	1
20	Impeller	5230-012-09	5230-012-09	5231-011-09	5230-011-09	5230-010-09	5230-010-09	1
21	Base plate	5230-060-00	5230-060-00	5230-060-00	5230-060-00	5230-060-00	5230-060-00	1
22	#10 x 1/2" SS self tapping screw	1707-008-00	1707-008-00	1707-008-00	1707-008-00	1707-008-00	1707-008-00	10

(\* Standard hardware item, available locally.

**For Replacement Parts, contact dealer where pump was purchased.**

Please provide following information:  
 -Model number  
 -Serial number (if any)  
 -Part description and number as shown in parts list

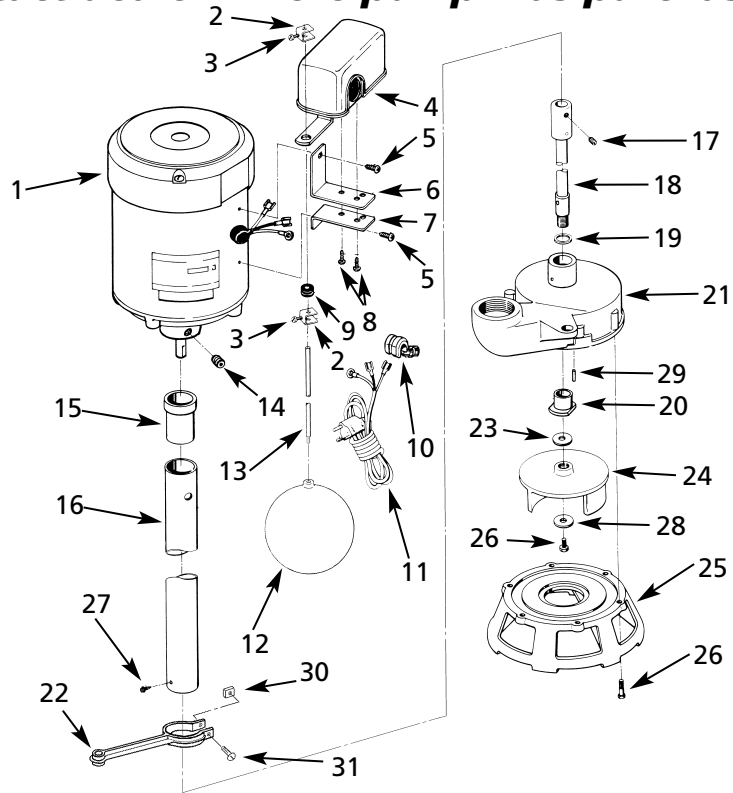

Figure 4 — Replacement Parts Illustration

**Replacement Parts List**

No.	Ref. Description	Part Number For Models:			Qty.
		4020-95 30" Cast Iron	4022-95 42" Cast Iron	4021-98 30" Stainless Steel	
1	Motor	1626-058-00	1626-058-00	1626-058-00	1
2	Float rod stop	2178-004-00	2178-004-00	2178-004-00	2
3	Float rod stop screw (18-8 stainless)	1707-001-00	1707-001-00	1707-004-00	2
4	Switch	5460-000-00	5460-000-00	5460-000-00	1
5	#10 x 1/4" Phillips sheet metal screw	*	*	*	2
6	Top switch bracket	2191-005-00	2191-005-00	2191-005-00	1
7	Bottom switch bracket	2191-004-00	2191-004-00	2191-004-00	1
8	#8-32 UNC x 3/8" round hd machine screw	*	*	*	2
9	Switch grommet	2193-000-00	2193-000-00	2193-000-00	1
10	Strain relief bushing	2191-007-00	2191-007-00	2191-007-00	1
11	Line cord	1639-077-00	1639-077-00	1639-077-00	1
12	Float	5239-107-00	5239-107-00	5239-107-00	1
13	Float rod	5230-104-00	5230-104-00	5230-104-00	1
14	1/4"-20 UNC x 1/4" set screw	*	*	*	3
15	Tube insert	2180-001-00	2180-001-09	2180-001-00	1
16	Tube column	2180-000-00	2180-003-00	2180-000-02	1
17	Shaft set screw (303 stainless)	1713-004-00	1713-004-00	1713-004-00	3
18	Shaft assembly (includes #17)	4020-140-90	4022-140-90	4021-140-90	1
19	Thrust washer	1237-000-00	1237-000-00	-	1
20	Bearing	2196-000-00	2196-000-00	2196-002-00	1
21	Volute (includes #20)	2174-000-01	2174-000-02	2174-001-01	1
22	Standoff bracket	5230-102-00	5230-102-00	5230-102-00	1
23	Impeller shims: consists of (1) .010, (1) .020, (1) .030"	1682-000-90	1682-000-90	1682-000-90	1
24	Impeller	2176-000-01	2176-000-01	2176-002-01	1
25	Base	2175-000-01	2175-000-01	2175-001-01	1
26	1/4"-20 UNC x 7/8" cap screw (18-8 stainless)	1718-001-00	1718-001-00	1718-001-00	7
27	#8-32 UNC x 1/4" slotted hex hd self tapping screw (18-8 stainless)	1699-003-00	1699-003-00	1699-003-00	4
28	Impeller washer	2176-001-00	2176-001-00	2176-001-00	1
29	1/8" x 1/2" Pin	-	-	2196-003-00	1
30	Machine nut	*	*	*	1
31	Machine screw	*	*	*	1

(\*) Standard hardware item, available locally.

