

Please read and save this Repair Parts Manual. Read this manual and the General Operating Instructions carefully before attempting to assemble, install, operate or maintain the product described. Protect yourself and others by observing all safety information. The Safety Instructions are contained in the General Operating Instructions. Failure to comply with the safety instructions accompanying this product could result in personal injury and/or property damage! Retain instructions for future reference. AMT reserves the right to discontinue any model or change specifications at any time without incurring any obligation.

©2006 American Machine & Tool Co., Inc. of PA, A Subsidiary of The Gorman-Rupp Company, All Rights Reserved.

WARNING Periodic maintenance and inspection is required on all pumps to insure proper operation. Unit must be clear of debris and sediment. Inspect for leaks and loose bolts. Failure to do so voids warranty.

3-Inch Trash Pump

Refer to form 1808-633-00 for General Operating and Safety Instructions.

Description

These trash pumps are high capacity, heavy duty, centrifugal, engine driven, self-priming (to 20 ft. lift), portable units. The pumps are equipped with a precision lapped mechanical seal to reduce leakage, carrying handle, and a clog-resistant impeller capable of handling solids up to 1-1/2" diameter (up to 25% by volume). A 3" NPT suction strainer is included. Handles liquids from 40° to 180° F (4° to 82° C). For use with nonflammable liquids compatible with pump component materials.

NOTE: Electric-start models require a 12-volt, 32 amp hour battery (not included).

Specifications

Suction Inlet 3" NPT
 Discharge Outlet 3" NPT
 Dimensions (overall) 28 L x 22 W x 24 H
 Engine Speed 3600 RPM
 Basic Construction Aluminum w/iron
 impeller and wearplates

Maintenance

To prevent accidental starting always remove the spark plug or disconnect and ground the spark plug wire before attempting to service or remove any component.

WARNING attempting to service or remove any component.

CLEANING

These units are designed so that for most cleanout or clogging problems it should not be necessary to remove hoses or piping. The suction area and impeller chambers can be reached by removing (2) threaded handles (Ref. No. 22) and removing suction cleanout cover plate (Ref. No. 21) and gasket (Ref. No. 20).

NOTE: When replacing cleanout cover plate, carefully wipe clean all surfaces on which the gasket has contact. Also, make sure the gasket is in position.

MECHANICAL SEAL REPLACEMENT Refer to figures 1 and 2.

NOTE: Always replace the seal seat (Ref. No. 8), seal cartridge (Ref. NO. 9), and shaft sleeve (Ref. No. 10) to ensure proper mating of mechanical seal components!

1. Unthread cap screws (Ref. No. 24) and remove casing (Ref. No. 19) and casing seal (Ref. No. 7) from adapter (Ref. No. 9).
2. Unthread screws (Ref. No. 13) and remove volute (Ref. No. 14) from adapter.
3. Unscrew impeller (Ref. No. 12) from the engine shaft. Remove the impeller shims (Ref. No. 11), shaft sleeve and seal cartridge (Ref. No. 11), shaft sleeve and seal cartridge from engine shaft. Use a rubber mallet or soft block of wood to loosen impeller. Turn counterclockwise.
4. Unthread cap screws (Ref. No. 3) and remove the adapter from the engine mounting face.

5. Push seal seat from the adapter recess with a screwdriver.
6. Clean the adapter recess before inserting a new seal seat.
7. Carefully wipe the polished surface of the new seal seat with a clean cloth.
8. Wet the rubber portion of the seal seat with a light coating of soapy water.
9. Press the new seal seat squarely into the cavity in the adapter. If the seal seat does not press squarely into the cavity, it can be adjusted in place by pushing on it with a piece of pipe. Always use a piece of cardboard between the pipe and the seal seat to avoid scratching the seal seat. (This is a lapped surface and must be handled very carefully).
10. After the seal seat is in place, ensure that it is clean and has not been marred.
11. Using a clean cloth, wipe the shaft and make certain that it is perfectly clean.
12. Secure the adapter on the engine mounting face.

NOTE: Tighten cap screws **EVENLY** to avoid cracking rabbet on engine mounting face.

13. Apply a light coating of soapy water to the inside rubber portion of seal cartridge and slide onto the shaft sleeve. Slip the shaft sleeve with seal cartridge onto the engine shaft.

IMPORTANT: Before installing new shaft sleeve, apply a bead of non-hardening, pliable sealant (such as Permatex® Form-A-Gasket® No. 2) to motor shaft shoulder.

14. Replace any impeller shim removed in disassembly.
15. Screw the impeller back in place tightening until it is seated against shims and shaft sleeve.
16. Remount volute with fasteners.
17. Refer to section entitled SHIM ADJUSTMENT at this time if shaft sleeve or any other parts listed therein have been replaced.
18. Inspect position of flapper valve assembly (Ref. No. 15) to insure proper movement and seating.
19. Replace O-ring seal on volute rabbet.

NOTE: Always inspect O-ring seals. Replace when cracked or worn. Wet O-ring with soapy water for ease of assembly.

20. Remount casing.
21. Remount any other parts and reconnect spark plug wire. Pump should now run with renewed original performance.

SHIM ADJUSTMENT

1. When installing a replacement impeller, engine, shaft sleeve, adapter, or volute, it may be necessary to vary the number of impeller shims (Ref. No. 11) that will be required. This is easily done by adding one 0.010" shim more than was removed and reassembling pump as described in Mechanical Seal Replacement section.
2. Insure that volute (Ref. No. 14) and adapter (Ref. No. 4) are fitted firmly (check fastener Ref. Nos. 3 & 13). Remove spark plug wire from engine and turn engine over by pulling the recoil starter. If engine does not run freely, disassemble pump and remove one shim.
3. Proper running clearance is 0.010".
4. Follow the above procedure until proper clearance is obtained. This will insure maximum performance.

IMPELLER AND WEARPLATE REPLACEMENT

Impeller (Ref. No. 12), volute/wearplate (Ref. No. 14) and rear wearplate (Ref. No. 5) are subject to wear only by abrasive sand or sediment laden liquids. If badly worn, all these parts can be replaced easily and the pump thus restored to full efficiency.

NOTE: When the clearance between the impeller and the volute/wearplate exceeds 1/16" at the face of the impeller or 1/8" on the outside diameter of the impeller, it may be necessary to take corrective action. The increased clearance can cause lengthened priming and decreased capacity to your unit. If performance is satisfactory for your application, it is recommended that no corrective maintenance be performed regardless of what clearances on your unit may have developed. This is because increased clearances in themselves are not generally harmful to your pump. Normally, new pump clearances can be restored by simply shimming behind the impeller. (Add shim washers Ref. No. 11). If the impeller is badly worn, it is recommended that the impeller be replaced. This is usually all that is required since only on abrasive surfaces does the cast iron wearplate show deterioration. Occasionally a stone or hard object might get caught in the impeller and cause damage to the volute/cutwater. In these cases follow the instructions below for replacement and refer to Figure 1.

1. Disassemble pump for access as described in Mechanical Seal Replacement, steps 1 and 2.
2. Replace parts as necessary.

NOTE: When replacing volute/wearplate, attach flapper valve assembly (Ref. No. 15) to the new volute with fastener (Ref. No. 16).

3. To replace rear wearplate (Ref. No. 5), remove fasteners (Ref. No. 6) after impeller has been removed.

NOTE: Before installing new parts, clean all mating surfaces thoroughly.

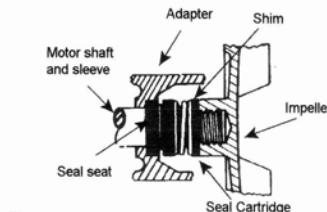

Figure 2 - Mechanical Seal

For Replacement Parts, contact dealer where pump was purchased

Please provide the following information:

- Model Number
- Serial Number (if any)
- Part description and number as shown in parts list

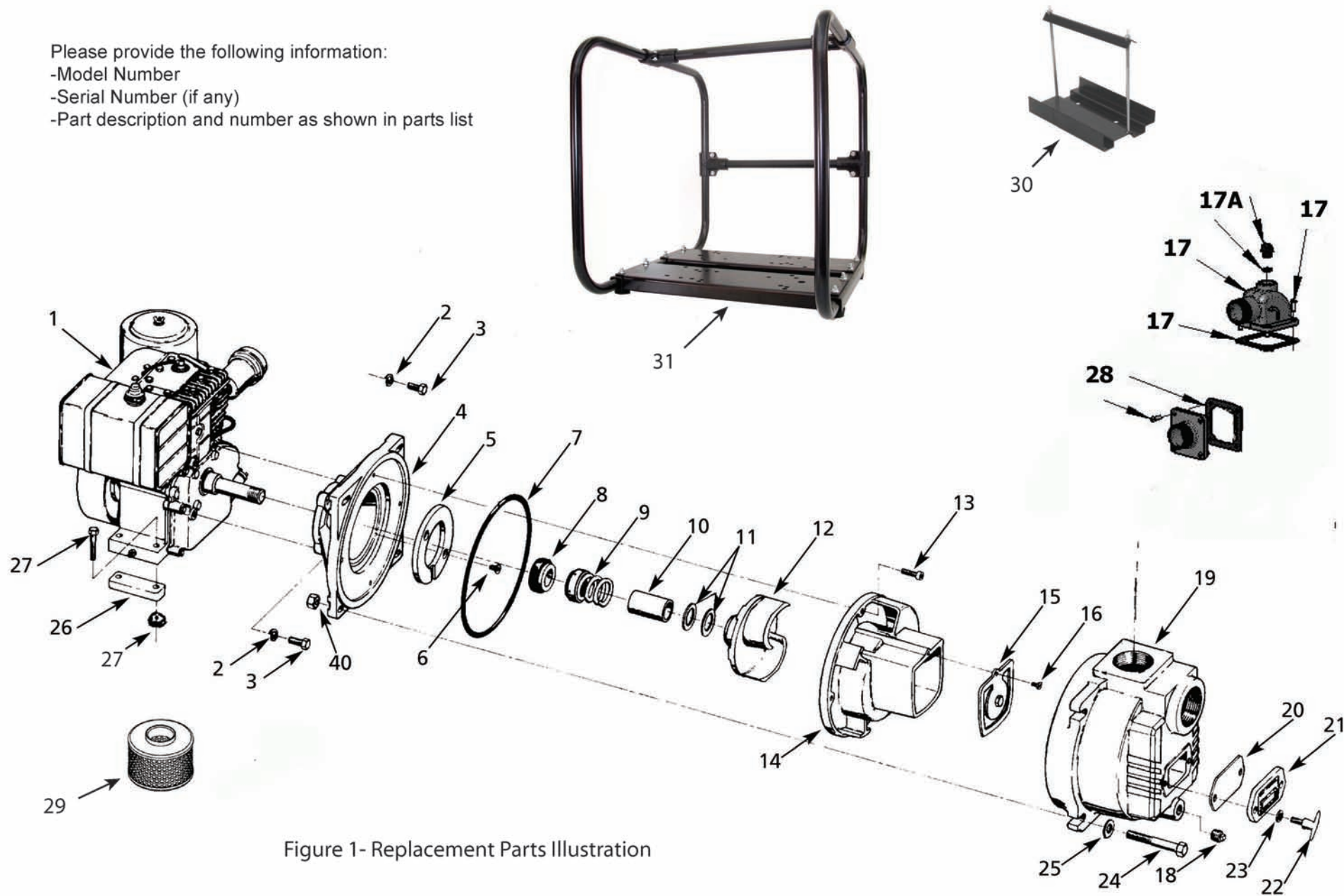

Figure 1- Replacement Parts Illustration

Replacement Parts List

Specifications Information and Replacement Parts Manual

3941-96, 3942-D6, 3943-96, 3944-96, 3946-96

| Ref. No. | Description | Part No. | Qty | Ref. No. | Description | Part No. | Qty. |
|----------|---|-------------|-----|----------|---|-------------|------|
| 1 | ●Engine 3941-96 B&S 8 HP | 1639-024-00 | 1 | 16 | Flat head screw SS | * | 1 |
| | ●Engine 3943-96 Honda 9 HP | 1639-026-00 | 1 | 17 | 3" NPT Male Discharge Flange Kit | 3941-080-90 | 1 |
| | ●Engine 3944-96 Honda 9 HP E-Start | 1639-028-00 | 1 | | Includes Flange, 4 bolts, and gasket | | |
| | ●Engine 3946-96 B&S 8 HP E-Start | 1639-027-00 | 1 | 17A | Fill Plug and O-Ring Kit | 3SXB-170-90 | 1 |
| | ●Engine 3942-D6 10 HP Diesel | 1639-039-00 | 1 | 18 | 3/4" NPT pipe plug | * | 1 |
| 2 | Lock washer | * | 4 | 19 | Casing for male flanges | 2113-001-02 | 1 |
| 3 | Hex head screw | * | 4 | 20 | Cleanout gasket | 2115-003-00 | 1 |
| 4 | Adapter | 2184-001-01 | 1 | 21 | Cleanout plate | 2115-002-01 | 1 |
| 5 | Wearplate | 2182-004-01 | 1 | 22 | Cleanout handle | 1601-000-00 | 2 |
| 6 | 5/16" UNC x 1/2" Flat head screw, SS | 1741-000-00 | 2 | 23 | Flat washer | * | 2 |
| 7 | O-ring | 2185-000-00 | 1 | 24 | Hex head screw | * | 4 |
| | | | | 25 | Flat washer | * | 8 |
| 8 & 9 | Seal seat and cartridge - Viton/Silicon Carbide | 1640-167-90 | 1 | 26 | Raising block | 1990-021-00 | 2 |
| KIT | Complete seal kit includes: 7,8,9,10,15,20 | S394-BSC-K0 | 1 | 27 | Hex head screw and nut | * | 4 |
| 10 | Shaft sleeve | 1555-000-00 | 1 | 28 | 3" NPT male suction flange kit | 3941-050-90 | 1 |
| 11 | Impeller shims: contains one each .010" .020" .030" | 1656-000-90 | 1 | | Includes flange, 4 bolts and gasket | | |
| 12 | Impeller | 3945-012-03 | 1 | 29 | 3" NPT Suction strainer | C520-90 | 1 |
| 13 | Hex head screw SS | * | 2 | 30 | †Battery tray kit includes | 1696-BAT-K0 | 1 |
| | | | | | †12" Battery cable (not shown) | | |
| 14 | Volute | 2184-002-01 | 1 | | †30" Battery cable (not shown) | | |
| 15 | Flapper valve assembly includes Ref. 16 | 3590-070-90 | 1 | 31 | Roll cage frame assembly | 1696-100-K0 | 1 |
| | | | | * | Replacement flange gasket kit (2 per) for Ref. Nos. 17 and 28 | 3941-301-90 | 1 |

(*) Standard hardware item, available locally.

(●) For engine parts refer directly to engine manufacturer.

(†) Electric start models only

NOTE: Wheel kit available separately; order model A735-90