



Engine Driven Trash Pumps

- **Cast Iron or Cast Aluminum Construction**
- **Buna N/Silicon Carbide Mechanical Seal and O-Ring**
- **2", 3" or 4" NPT Port Sizes**
- **Self-Priming up to 20 Ft.**
- **Engine Options: B&S, Honda and Vanguard**
- **Available in 3-1/2 to 16 HP Engines**
- **Pumps Include Heavy Duty Base or Roll Frame**
- **Solids Handling up to 2" Diameter**



2" Pump with Wheel Kit



3" Engine Driven Trash Pump

The AMT line of Engine Driven Trash pumps is designed for applications which require high flow efficiency and solids handling capability. Pumps are constructed of heavy duty sand cast components featuring removable/replaceable Cast Iron volutes, impellers and wearplates. Simple cleanout design permits easy removal of trash and debris without disconnecting hoses. Pumps are available with side valve or overhead valve engines from various engine manufacturers. An electric start option is available on many models.

AMT Engine Driven Trash pumps are reliable, cost effective and low maintenance. Many are readily available "Off-the-Shelf" for fast same day shipment. For use with nonflammable liquids which are compatible with pump component materials.



4" Engine Driven Trash Pump

Performance Engine Driven Trash Pumps

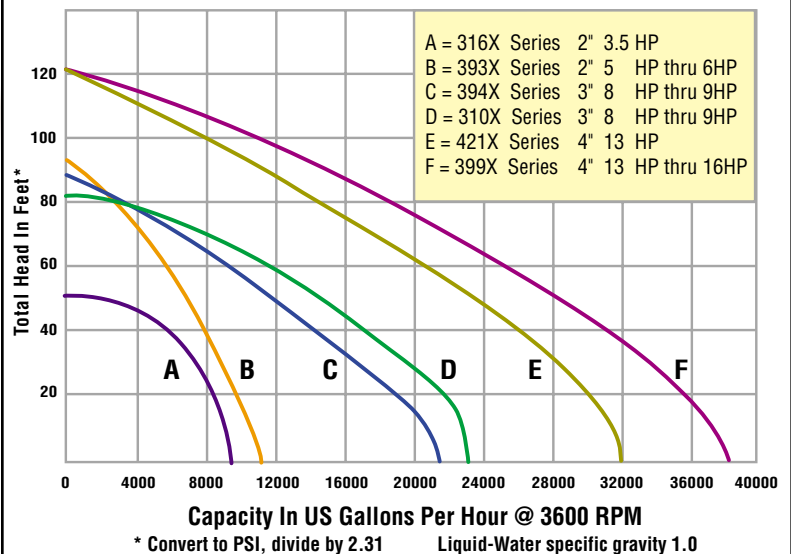

2" Engine Driven Trash Pumps



Model#	Driver	Ship Wt.	Run Time	Tank Size
3163-95	3.5HP B&S	76 lbs.	150 min.	3.0 qt.
3930-95	6.5HP B&S INTEK I/C*	110 lbs.	120 min.	4.0 qt.
3932-95	5.5HP HONDA*	104 lbs.	100 min.	3.8 qt.
3935-95	5.5HP B&S INTEK	106 lbs.	106 min.	3.0 qt.

Construction - Cast Iron

Solids Handling - 1"

3" Engine Driven Trash Pumps



Model#	Driver	Ship Wt.	Run Time	Tank Size
3941-96	8HP B&S Intek PRO*	143 lbs.	90 min.	4.0 qt.
3943-96	9HP HONDA*	153 lbs.	100 min.	6.4 qt.
3944-96	9HP HONDA***	185 lbs.	100 min.	6.4 qt.
3946-96	8HP B&S I/P***	174 lbs.	90 min.	6.0 qt.
3947-96	9HP VANGUARD*	167 lbs.	100 min.	6.4 qt.

Construction - Cast Aluminum w/Iron Wearparts Solids Handling - 1-1/2"

3" Premium Engine Driven Trash Pumps

feature additional cleanout covers for heavy debris application



Model#	Driver	Ship Wt.	Run Time	Tank Size
3100-96	8HP B&S Intek PRO*	151 lbs.	90 min.	4.0 qt.
3103-96	9HP HONDA*	169 lbs.	100 min.	6.4 qt.
3104-96	9HP HONDA***	179 lbs.	100 min.	6.4 qt.
3106-96	8HP B&S I/P***	169 lbs.	90 min.	6.0 qt.
3107-96	9HP VANGUARD*	161 lbs.	100 min.	6.4 qt.

Construction - Cast Aluminum w/Iron Wearparts Solids Handling - 1-1/2"

Optional Wheel Kits

for frame mounted pumps (3.5 thru 9HP)



Model#	Features	Ship Wt.
A734-90	Includes 10" semi-pneumatic tires on steel wheels with cast iron clamps and steel handle for universal mounting to frame.	26 lbs.
A735-90	Includes 16" pneumatic tires on steel wheels with cast iron clamps and steel handle for universal mounting to frame.	29 lbs.

4" Premium Engine Driven Trash Pumps



Model#	Driver	Net Wt.	Run Time	Tank Size
3993-96	16HP B&S VANGUARD***	294 lbs.	100 min.	9.0 qt.
3994-96	13HP HONDA***	299 lbs.	80 min.	6.9 qt.
4210-96	13HP B&S VANGUARD*	238 lbs.	90 min.	6.0 qt.

Construction - Cast Aluminum w/Iron Wearparts Solids Handling - 2"

Standard Features

- > Two NPT Pipe Nipples
- > Buna N/Silicon Carbide Mechanical Seal
- > O-Ring Casing Seal
- > Self-primes to 20 Ft. with Built In Check Valve
- > Stainless Steel Shaft Sleeve
- > Steel Suction Strainer Included
- > Cast Iron Replaceable Volute/Wearplate & Impeller
- > Maximum Temperature 180° F
- > Maximum Working Pressure 60 PSI
- > 2" & 3" Models Include Steel Roll Frame
- > 4" Models include Wheel Kit and Base Rails
- > Intek, Vanguard and Honda Engines are Overhead Valve (OHV) Designs

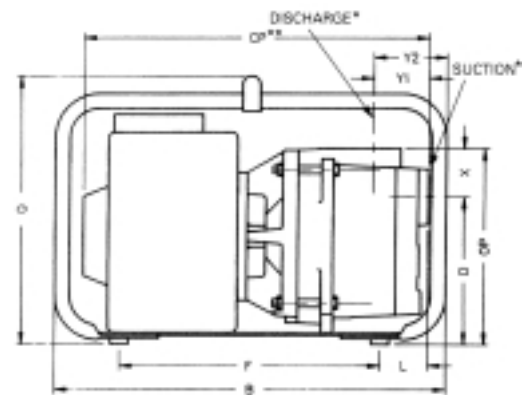

2" & 3" Models

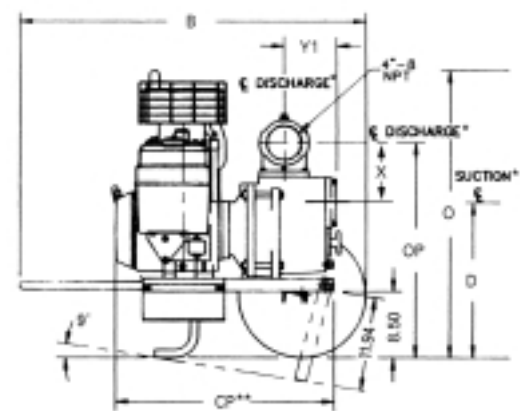

4" Models

(*) Standard NPT (female) pipe thread.

(**) This dimension may vary due to engine manufacturer's specifications.

NOTE: Dimensions have a tolerance of ±1/8".

* Oil Alert Included

***12V DC Electric Start (battery not included)



American Machine & Tool Co.

400 Spring Street, Royersford, PA 19468

(610) 948-3800 Fax (610) 948-5300

E-mail: amt@fast.net

www.amtpump.com

MODEL#	WIDTH	B	CP**	D	F	L	O	OP	X	Y1	Y2
3163-95	15.5	19.0	17.5	6.8	8.5	4.5	16.0	9.5	2.6	3.2	4.6
393X Series	17.0	22.0	19.0	8.5	8.5	6.0	19.3	11.5	3.0	3.5	5.3
394X Series	21.3	27.3	25.5	11.0	15.0	6.0	23.0	14.5	3.5	5.0	6.0
310X Series	21.3	27.3	20.1	11.6	15.0	6.0	23.0	13.6	2.0	8.3	11.3
421X Series	37.5	44.1	27.4	19.6	N/A	N/A	36.3	27.5	7.8	6.5	N/A
399X Series	37.5	44.1	27.4	19.6	N/A	N/A	36.3	27.5	7.8	6.5	N/A

AMT reserves the right to discontinue any model or change specifications at any time without incurring any obligation.

393X-CP / 0901