

Please read and save this Repair Parts Manual. Read this manual and the General Operating Instructions carefully before attempting to assemble, install, operate or maintain the product described. Protect yourself and others by observing all safety information. The Safety Instructions are contained in the General Operating Instructions. Failure to comply with the safety instructions accompanying this product could result in personal injury and/or property damage! Retain instructions for future reference.

# Pump Pedestal Adapters

Refer to form 1808-635-00 for General Operating and Safety Instructions.

## Description

### MODEL 3891-99

Used with pumps that require a NEMA 56J Face with threaded shaft.  
Equipped with a stainless steel shaft which extends  $2\frac{3}{8}$ " from mounting face.  $\frac{5}{8}$ " diameter threaded  $1\frac{1}{16}$ " from end of shaft with  $7/16$ -20 UNF-2A threads.  
Opposite end is  $\frac{3}{4}$ " diameter with a keyway.

### MODEL 3890-99

Used with pumps that require a NEMA 56C Face with keyed shaft.  
The unique design of the pump head is such that no part of the pump pedestal adapter (including shaft) normally makes contact with the fluid being pumped. This allows the pump pedestal adapter for both type 316 stainless steel and bronze pumps to be one unit made of cast iron (steel shaft).

### MODELS 3891-99 AND 3890-99

With pump pedestal attached, these pumps can be installed with direct-coupling drive or pulley drive and by electric motor or belt driven with gasoline engines.

## Dimensions (Inches)

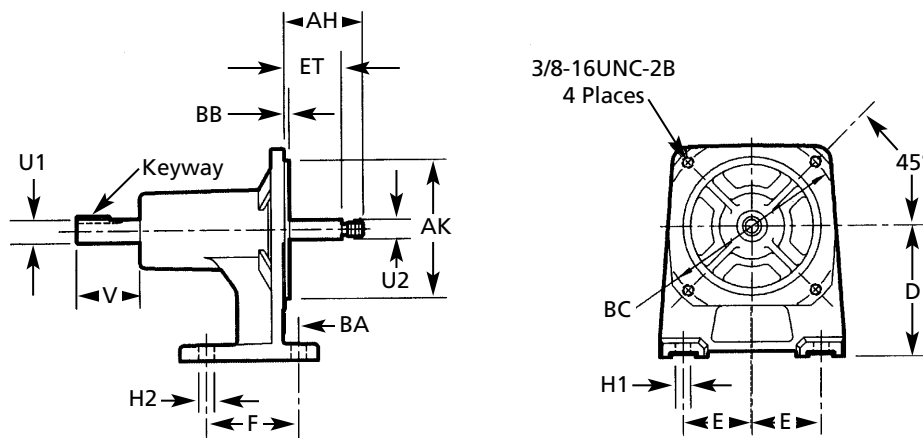

Figure 1 - Dimensions for Model 3891-99

AH	AK	BA	BB	BC	D	E	ET	F	H1/H2	U1	U2	V	Keyway
2.56	4.50	0.50	0.16	5.88	4.25	2.25	1.87	3.00	0.50	$\frac{3}{4}$ "	$\frac{5}{8}$ "	1.97	$\frac{3}{16}$ " X $\frac{3}{16}$ " X 1"

NOTE: All dimensions have a tolerance of  $\pm 1/8$ ".

## Specifications

### Shaft material

3891-99	303 Stainless steel
3890-99	Cold rolled steel

### Dimensions

3891-99	$6\frac{7}{8}$ " H x 6" W x $9\frac{1}{4}$ " L
3890-99	$6\frac{7}{8}$ " H x 6" W x $9\frac{3}{8}$ " L

Weight . . . . . 11 lbs (approx.)

Basic construction . . . . . Cast iron w/ epoxy paint

Ball bearings . . . . . Double heavy-duty

Pump RPM . . . . . 4000 (max.)

Find desired pump speed in accordance with the performance chart. Select the driver with the proper RPM and corresponding pulley sizes.

## Pulley Drive Chart

Pump Speed RPM	Motor Speed	Pully Diameter*	
		Motor	Pump
1725	1725 RPM	3"	3"
	3450	2 $\frac{1}{2}$ "	5"
2300	1725	4"	3"
	3450	3"	4 $\frac{1}{2}$ "
2800	1725	4"	2 $\frac{1}{2}$ "
	3450	2 $\frac{1}{2}$ "	3"
3450	1725	6"	3"
	3450	3"	3"

\*All A section, single groove, over 1 HP double groove pulleys/belts should be used.

# Pump Pedestal Adapters

## Dimensions (Inches) (Continued)

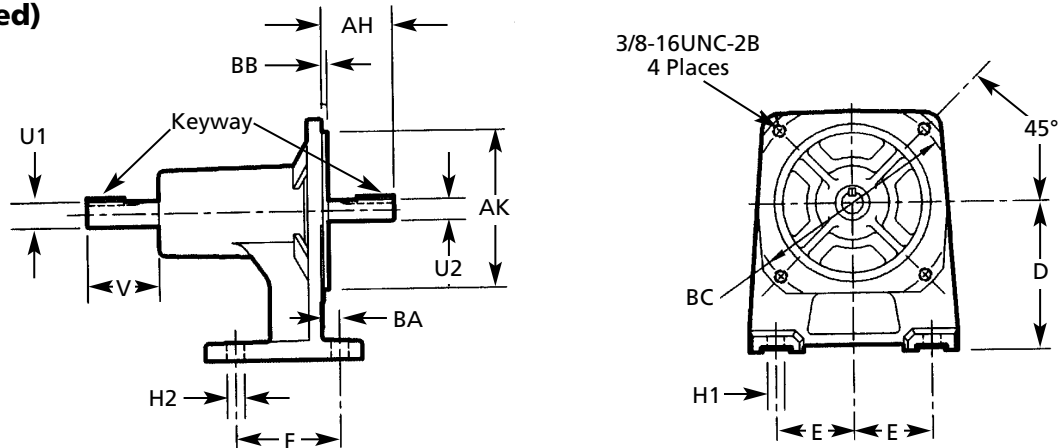

Figure 2 – Dimensions for Model 3890-99

AH	AK	BA	BB	BC	D	E	F	H1/H2	U1	U2	V	Keyway
2.56	4.50	0.50	0.16	5.88	4.25	2.25	3.00	0.50	3/4"	5/8"	1.97	3/16" X 3/16" X 1"

NOTE: All dimensions have a tolerance of ± 1/8".

### Assembly

Assemble bearing housing (Ref. No. 2) to pump (See pump manual "Maintenance").

NOTE: The hardware (see pump manual "Repair Parts List") supplied with the pump head is used to attach the pump to the pedestal.

NOTE: For proper selection of pump head unit, contact dealer where pedestal was purchased.

### ROTATION MODEL 3890-99 (KEYED SHAFT MODEL)

Rotation will depend on pump being driven. Check before attempting to install unit in service (see pump manual).

### ROTATION MODEL 3891-99 (THREADED SHAFT MODEL)

This unit can only be used with counterclockwise rotation (CCW) facing the threaded shaft. Use only with pumps that turn CCW when facing front of pump (shaft end of motor). A vial containing a removable grade of thread sealant (Ref. No. †) is included

with the 3891-99 pedestal. This is to be applied to the threaded end of the shaft (Ref. No. 4) just before installing impeller for last time (see pump manual "Shim Adjustment"). This will help control the impeller from loosening in the event that the unit is started in the wrong direction (i.e., as in 3-phase operation, etc.).

**CAUTION** Failure to follow the above information may cause impeller to unscrew and damage pump head, cause property damage and/or personal injury.

### Maintenance

**WARNING** Disconnect from power source before servicing or inspecting the pump for any reason.

### BEARING HOUSING SERVICE

1. Remove pump head assembly (See pump manual "Maintenance")
2. Remove the shaft bearings (Ref. No. 3) and shaft (Ref. No. 4) as an assembly by first removing the snap ring (Ref. No. 6) and wave washer (Ref. No. 5).

3. Push the shaft/bearing assembly out of the bearing housing (Ref. No. 2) by rapping on the pump end of shaft with soft mallet, or block of wood and a hammer.
4. The shaft bearings can now be removed from the shaft.
5. If shaft bearings have been removed from shaft and bearing housing, replace by sliding bearing or shaft to shoulder.
6. Replace shaft bearing assembly by sliding assembly into housing, pump end first. Push shaft bearing assembly completely in by gently tapping on keyway end of shaft with soft mallet.
7. Replace wave washer and snap ring.
8. Reassemble pump to pedestal (See pump manual "Maintenance").

**For Repair Parts contact dealer where pedestal was purchased**

Please provide following information:

- Model number
- Serial number (if any)
- Part description and number as shown in parts list

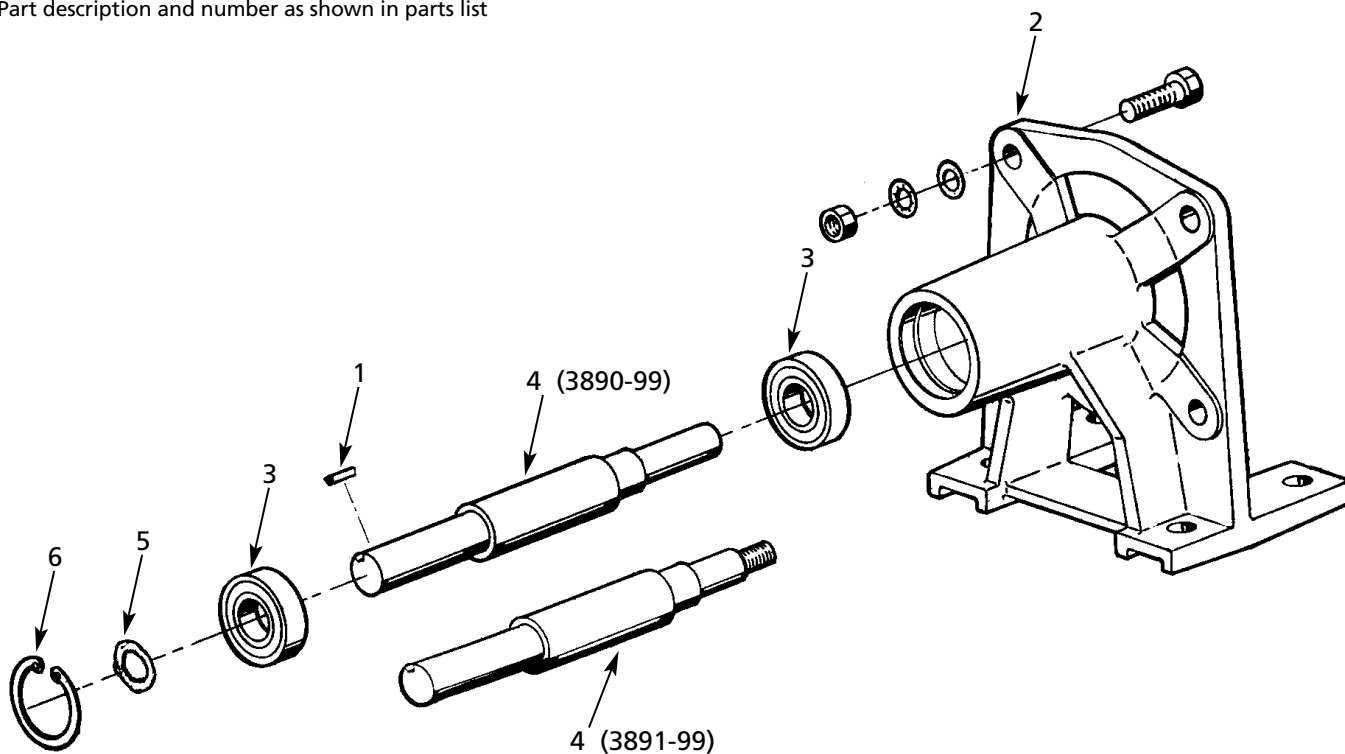

Figure 3 – Repair Parts Illustration

**Repair Parts List**

Reference Number	Description	Part Number	Quantity
1	3/16" x 3/16" Shaft key	1517-000-00	1
2	Bearing housing	3890-090-09	1
3	3/4" I.D. Ball bearing	1695-031-00	2
4	Keyed shaft (3890-99)	1696-067-00	1
	Threaded shaft (3891-99)	1696-066-00	1
5	Wave washer	1806-023-00	1
6	Snap ring	1695-034-00	1
t	Thread sealant (3891-99 only)	1696-075-00	1

(t) Not shown.

