

Please read and save this Repair Parts Manual. Read this manual and the General Operating Instructions carefully before attempting to assemble, install, operate or maintain the product described. Protect yourself and others by observing all safety information. The Safety Instructions are contained in the General Operating Instructions. Failure to comply with the safety instructions accompanying this product could result in personal injury and/or property damage! Retain instructions for future reference.

# 1½-Inch Self-Priming Centrifugal Pumps

Refer to form 1808-634-00 for General Operating and Safety Instructions.

## Description

These self-priming centrifugal pumps are used for continuous transfer pumping of chemicals from tanks and sumps, and in chemical process and batch lines, waste water treatment and agricultural pumping applications.

Pumps self-prime (after filling pump casing) to 6 feet suction lift and will handle liquids with entrapped gases. Maximum viscosity is 100 SSU. Casing working pressure to 75 psi. For use with nonflammable, non-abrasive liquids compatible with pump component materials.

### 316 STAINLESS STEEL UNITS

Stainless steel pumps will handle many acids, alkalis, caustics, solvents, brines and other fluids compatible with Type 316 stainless steel body and impeller, and Teflon mechanical seal (comprised of ceramic seat, carbon head and 316 stainless steel spring). Handle liquids from 40° to 250° F (4° to 121° C).

### BRONZE UNITS

Bronze units handle many acids and organic material compatible with bronze body, 316 stainless steel impeller, and Viton mechanical seal (comprised of ceramic seat, carbon head and stainless steel spring). Handle liquids from 40° to 200° F (4° to 93° C).

## Maintenance

**⚠ WARNING** Make certain that power source is disconnected before attempting to service or disassemble any components! If power disconnect is out-of-sight, lock it in open position and tag to prevent application of power.

### MECHANICAL SEAL REPLACEMENT

Refer to Figures 2, 3 and 4.

**IMPORTANT:** Always replace both seal seat (Ref. No. 11) and seal head (Ref. No. 10) to insure proper mating of components! It is recommended that impeller seal (Ref. No. 14) also be replaced when replacing shaft seal.

1. Unthread fasteners (Ref. No. 7) and remove casing (Ref. No. 16) and casing seal (Ref. No. 8).

## Specifications

Model No. 316 Stain- less Steel	Seal Mat'l	Model No. Cast Bronze	Seal Mat'l	MOTOR				Ship Weight
				HP	RPM	Phase	Voltage	
3890-98	Teflon	3890-97	Viton	3/4	3450	1	115/230, 60 Hz	45 lbs.
3891-98	Teflon	3891-97	Viton	1½	3450	1	115/230, 60 Hz	55
3892-98	Teflon	3892-97	Viton	3/4	3450	3	230/460, 50/60 Hz	40
3893-98	Teflon	3893-97	Viton	1½	3450	3	230/460, 50/60 Hz	48
3894-98	Teflon	3894-97	Viton	2	3450	3	230/460, 50/60 Hz	50

**NOTE:** Driver data is subject to change without notice, see label on driver for actual specifications.

## Performance

Model	GPM of Water at Total Head in Feet							Max. Head*	Max. Specific Gravity
	0'	10'	20'	30'	40'	50'	60'		
3890, 3892	69	61	52	42	24	4	–	52 ft.	1.3
3891, 3893	100	91	79	66	48	7	–	52	1.3
3894	130	123	113	99	82	61	26	63	1.1

(\*) Shut off; to convert to psi, multiply by specific gravity and divide by 2.31

# 1½-Inch Self-Priming Centrifugal Pumps

## Dimensions (Inches)

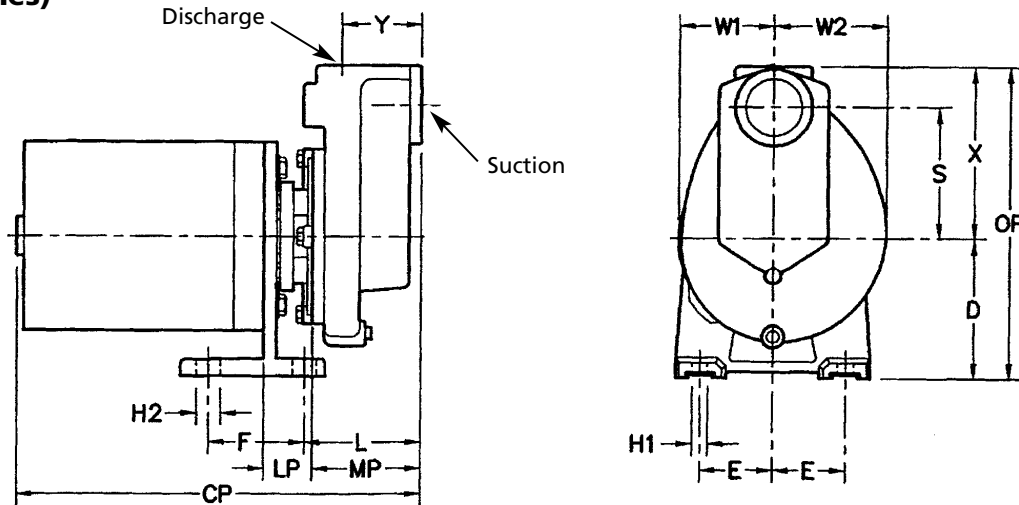

Figure 1 – Dimensions

Model	Suc.*	Dis.*	CP**	D	E	F	H1	H2	L	LP	MP	OP	S	W1	W2	X	Y
3890	1½"	1½"	15.13	4.25	2.25	3.00	0.50	0.75	4.56	0.96	4.38	9.50	4.00	2.88	3.50	5.25	3.94
3891	1½"	1½"	16.63	4.25	2.25	3.00	0.50	0.75	4.56	0.96	4.38	9.50	4.00	2.88	3.50	5.25	3.94
3892	1½"	1½"	14.50	4.25	2.25	3.00	0.50	0.75	4.56	0.96	4.38	9.50	4.00	2.88	3.50	5.25	3.94
3893	1½"	1½"	15.63	4.25	2.25	3.00	0.50	0.75	4.56	0.96	4.38	9.50	4.00	2.88	3.50	5.25	3.94
3894	1½"	1½"	15.63	4.25	2.25	3.00	0.50	0.75	4.56	0.96	4.38	9.50	4.00	2.88	3.50	5.25	3.94

**NOTE:** All dimensions have a tolerance of ± 1/8".

(\*) Standard NPT (female) pipe thread.

(\*\*) This dimension may vary due to motor manufacturer's specifications.

## Maintenance (Continued)

2. Unscrew impeller fastener (Ref. No. 15) from motor shaft (fastener unscrews CCW looking at motor shaft).

**NOTE:** Some motors use an open end 7/16" wrench across flats on rear of motor shaft (remove bearing cap for access) to prevent shaft from turning. Other motor shafts have a screwdriver slot instead of flats.

3. Unscrew impeller (Ref. No. 13) from motor shaft. Remove the impeller seal. Also, remove shims (Ref. No. 9) **DO NOT LOSE SHIMS.**

4. Pry seal seat from recess of impeller. Use caution so as not to damage or remove seal seat pin (Ref. No. 12) on Teflon seal equipped units.

5. Remove the adapter and casing cover (Ref. Nos. 3 and 6) by

unthreading fasteners (Ref. Nos. 4 and 5).

6. Press seal head from rear of casing cover.

7. Clean casing cover and impeller seal recesses and motor shaft. Make certain all surfaces are perfectly clean

before installing new seal parts.

**CAUTION** Handle seal parts with extreme caution and keep them clean. Do not touch polished seal faces with your hands. Do not apply lubricants on seal faces. This could cause a leak or premature seal failure.

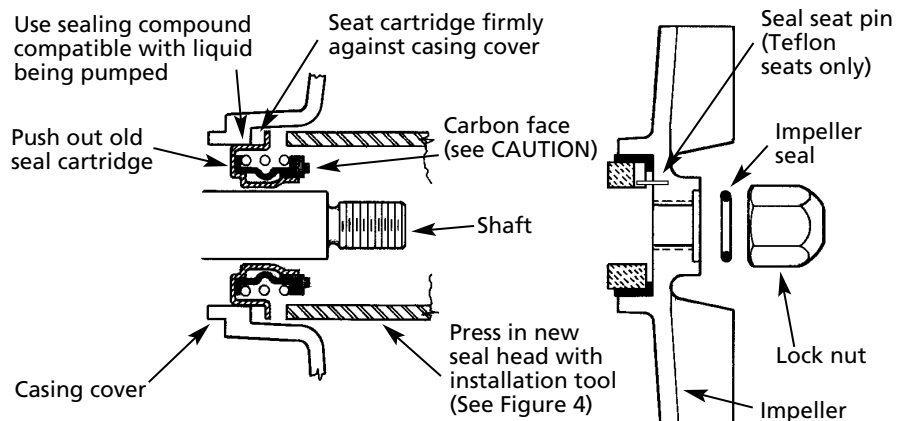
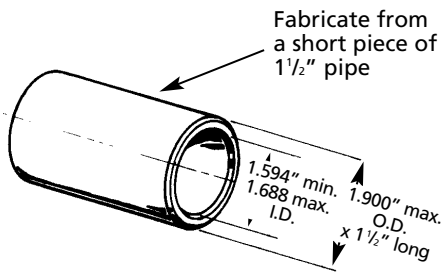

Figure 2 – Mechanical Seal Replacement (Teflon seal shown)

# Models 3890 thru 3894

## Maintenance (Continued)

8. Apply a light coat of sealing compound to new seal head (See Figure 2) and press it into casing cover recess using proper size tube or installation tool (See Figure 3). DO NOT press on carbon face or top of metal cup of the seal head. Install using flange only.



**Figure 3 – Seal Installation Tool**

9. Slide adapter and casing cover assembly onto motor mounting face. Attach with fasteners .

10. Press new seal seat squarely into impeller recess. Align slot in seal seat with seal seat pin on Teflon equipped units. Avoid scratching polished surface.

**NOTE:** Use a soft, clean piece of cloth on seal seat face when installing to prevent marring.

11. Replace any shim washers which may have been removed in disassembly (see SHIM ADJUSTMENT). Screw the impeller back in place, tightening until it is firmly seated.
12. Install impeller seal and install and tighten impeller lock nut.
13. Reinstall seal on casing cover rabbet. Remount casing with fasteners.

**NOTE:** Always flush pump thoroughly before use so as not to contaminate liquid being pumped.

**CAUTION** *If impeller is replaced, seal assembly should also be replaced as seal is usually damaged in disassembly. Also replace impeller washer.*

### SHIM ADJUSTMENT

When installing a replacement impeller (Ref. No. 13) or motor (Ref. No. 1), it may be necessary to adjust number of shims (Ref. No. 9) to ensure proper running clearance between impeller and casing. Proceed as follows:

**NOTE:** A proper running clearance is less than 0.010". (Face of impeller to mating face of casing.)

1. For impeller replacement, add one (1) shim (thinnest 0.010") in addition to those removed originally.

2. For motor replacement, add two (2) shims (both 0.010") in addition to those removed during disassembly.
3. Reassemble pump as described in Steps 11, 12, and 13.

**IMPORTANT:** Ensure that casing is snugly in place and check shaft to make sure it is turning freely. (Use 7/16" wrench or screwdriver to turn shaft.) If it turns freely, check to ensure that adapter casing cover and casing are fitted "metal to metal" where they meet on outside. If they are not "metal to metal", tighten fasteners (Ref. Nos. 2, 5, and 7) and recheck shaft for free turning. Tighten carefully, turning shaft while tightening so that motor bearings are not damaged in the event that too many shims were installed. If shaft seizes before fasteners are completely tight, disassemble pump and remove one (1) shim (thinnest 0.010") and repeat reassembly.

**For Replacement Parts, contact dealer where pump was purchased.**

Please provide following information:

- Model number
- Serial number (if any)
- Part description and number as shown in parts list

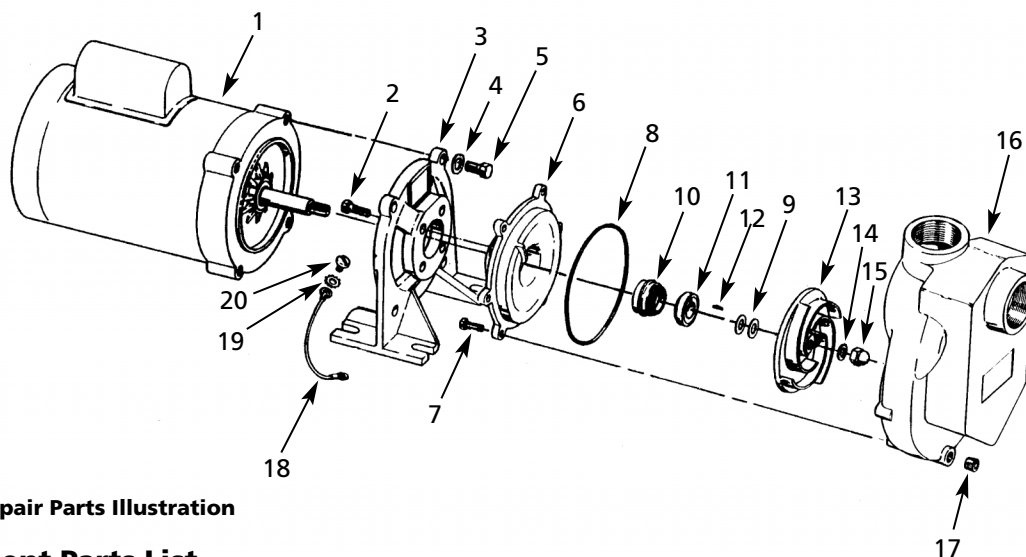

Figure 4 – Repair Parts Illustration

**Replacement Parts List**

Ref. No.	Description	Part Number for Models:	3/4 HP	1 1/2 HP	2 HP	Qty.
			3890 3892	3891 3893	3894	
1	Motor	-1 Phase TEFC -3 Phase TEFC	1626-051-00 1626-052-00	1626-050-00 1626-053-00	— 1626-054-00	1
2	Fastener		*	*	*	4
3	Adapter		3890-032-09	3890-032-09	3890-032-09	1
4	Washer		*	*	*	4
5	Fastener		*	*	*	4
6	Casing cover	-SS -Bronze	2105-003-01 2105-017-01	2105-003-01 2105-017-01	2105-003-01 2105-017-01	1
7	Fastener		*	*	*	6
8	Casing seal	-Teflon (standard on SS) -Viton (standard on Bronze)	2105-004-00 2105-023-00	2105-004-00 2105-023-00	2105-004-00 2105-023-00	1 1
9	Impeller shims (Pkg of 3)		1806-044-90	1806-044-90	1806-044-90	1
10 & 11	† Shaft seal	-Teflon (standard on SS) -Viton (standard on Bronze) -Neoprene/Ni-Resist (optional)	1641-162-91 1641-162-90 1641-162-94	1641-162-91 1641-162-90 1641-162-94	1641-162-91 1641-162-90 1641-162-94	1
12	⊠ Pin		1652-006-00	1652-006-00	1652-006-00	1
13	Impeller		2105-006-01	2105-007-02	2105-009-01	1
14	Impeller seal	-Teflon (standard on SS) -Viton (standard on Bronze)	2105-031-00 2105-037-00	2105-031-00 2105-037-00	2105-031-00 2105-037-00	1 1
15	Impeller fastener		1784-001-00	1784-001-00	1784-001-00	1
16	Casing	-SS -Bronze	2105-001-01 2105-016-01	2105-001-01 2105-016-01	2105-001-01 2105-016-01	1
17	Pipe plug		*	*	*	1
18	Ground wire		2105-042-00	2105-042-00	2105-042-00	1
19	Washer		*	*	*	1
20	Fastener		*	*	*	1

(†) Seal assembly available as a set only. Includes both seal head and seal seat.

(⊠) Seal seat pin used for Teflon® seals only.