

Please read and save this Repair Parts Manual. Read this manual and the General Operating Instructions carefully before attempting to assemble, install, operate or maintain the product described. Protect yourself and others by observing all safety information. The Safety Instructions are contained in the General Operating Instructions. Failure to comply with the safety instructions accompanying this product could result in personal injury and/or property damage! Retain instructions for future reference.

# Swimming Pool / Hot Tub Pumps

Refer to form 1808-634-00 for General Operating and Safety Instructions.

## Description

These bronze centrifugal pumps are designed for high volume liquid handling in spas or other applications where moderate pressures and high volumes are required. Handle liquids from 40° to 180° F (4° to 82° C). These pumps, with optional basket strainer (4530-99) attached, become highly effective self-priming (to 12 ft. lift) swimming pool pumps or filter pumps. Horsepower sizes are available that can be matched to a wide variety of swimming pool filters.

Model 3884-97 has a 2-speed motor. Low speed provides quiet, energy saving filtration and recirculation. High speed provides higher flow rates, increased pressure, and/or jetting massage action in spas, hot tubs and larger pools. For further information pertaining to your particular motor, see Specifications and Performance below. All units are manual models. No controls are supplied. For use with nonflammable, non-abrasive liquids compatible with pump component materials.

## Important Safety Instructions

When installing and using this electrical equipment, basic safety precautions should always be followed, including the following:

For specific Safety precautions for installation and electrical connection information and to reduce the potential for fire, electric shock, or injury, read and follow all information and instructions contained in the form 1808-634-00 Electric Motor Driven Pumps Operating Instructions.

## READ AND FOLLOW ALL INSTRUCTIONS

**⚠ WARNING** To reduce the risk of injury, do not permit children to use product unless they are closely supervised at all times.

**⚠ CAUTION** This pump is for use with permanently installed pools and may also be used with hot tubs and spas if so marked. Do not use with storable pools. A permanently installed pool is constructed in or on the ground or in a building such that it cannot be readily disassembled for storage. A storable pool is constructed so that it may be readily disassembled for storage and reassembled to its original integrity. For hot tub and spa pumps - Do not install within an outer enclosure or beneath the skirt of a hot tub or spa unless so marked.

## Specifications

Model	HP	Power Supply	RPM	115V F.L. AMPS	230V F.L. AMP	Suction Inlet	Discharge Outlet	Wt. (lb.)
3880-97	1/2	115/230V, 60Hz	3450	8.4	4.2	1 1/2" NPSC*	1 1/2" NPT*	25
3881-97	3/4	115/230V, 60Hz	3450	10.0	5.0	1 1/2	1 1/2	29
3882-97	1	115/230V, 60Hz	3450	14.0	7.0	1 1/2	1 1/2	32
3883-97	1 1/2	115/230V, 60Hz	3450	16.0	8.0	1 1/2	1 1/2	36
3884-97	2 (2-speed)	230V, 60Hz	3450/1725	-	11.2/2.7	1 1/2	1 1/2	45

**NOTE:** Driver data is subject to change without notice, see label on driver for actual specifications.

(\*) Standard (female) pipe thread.

## Performance

Model	GPM of Water @ Total Head in Feet						Max. Head (**)
	5'	10'	20'	30'	40'	50'	
3880-97	52	48	40	27	14	-	49 ft
3881-97	72	67	57	46	32	14	55
3882-97	87	82	72	61	47	28	58
3883-97	110	105	92	78	60	34	57
3884-97							
Hi-Speed	128	123	112	98	81	58	61
Lo-Speed	52	36	-	-	-	-	15

(\*\*) Shutoff; to convert to psi, multiply by specific gravity and divide by 2.31.

# Swimming Pool / Hot Tub Pumps

## Important Safety Instructions (Continued)

### SAVE THESE INSTRUCTIONS

A copper bonding conductor of no smaller than 8 AWG must be connected from the bonding lug on the motor to ALL metal parts of the pool, spa or hot tub structure, and to all electrical equipment, metal conduit, and metal piping, within 5 feet of the inside walls of a swimming pool, spa or hot tub, when the motor is installed within 5 feet of the inside walls of the swimming pool, spa, or hot tub.

**NOTE:** If the pump is located above the liquid level, a positive sealing foot valve or check valve must be installed at the end of the suction line or in the piping just before the pump. If the unit is used with optional strainer basket (4530-99) the foot valve or check valve will only be required when the suction lift or distance the pump is from the water level is greater than 10 feet.

If the 4530-99 strainer basket is not used it is recommended that another suitable means of straining foreign material out of the suction line be used.

### Maintenance

**⚠ WARNING** *Make certain that unit is disconnected from power source before attempting to service or remove any component.*

### MECHANICAL SEAL REPLACEMENT

Refer to Figures 1 & 2.

**IMPORTANT:** Always replace both seal seat (Ref. No. 9) and seal head (Ref. No. 10) to insure proper mating of components.

1. Unthread fasteners (Ref. No. 5) and remove casing (Ref. No. 13) and

casing seal (Ref. No. 8).

2. Unscrew impeller (Ref. No. 12) from motor shaft. Remove shims (Ref. No. 11) and retain for reassembly.

**NOTE:** Some motors use an open end 7/16" wrench across flats on rear of motor shaft (remove bearing cap for access) to prevent shaft from turning. Other motor shafts have a screwdriver slot instead of flats.

3. Slide old seal head from motor shaft.
4. Unthread fasteners (Ref. No. 6) and remove assembled adapter (Ref. No. 4) and casing cover (Ref. No. 7) from motor mounting face.
5. Pry seal seat from rear of casing cover with a screwdriver.
6. Clean casing cover seal seat recess before inserting new seal parts.
7. Wet rubber portion of new seal seat with a light coating of soapy water. Press seal seat squarely into casing cover recess. Avoid scratching polished surface.

**⚠ CAUTION** *Handle all seal parts with white gloves being careful to keep them clean. Do not touch polished seal faces with your hands. Do not put lubricants on seal face. This would cause a leak.*

8. Inspect polished face of seal seat and seal head to ensure they are clean and not marred.

9. Using a clean cloth, wipe shaft and make certain that it is perfectly clean.

**IMPORTANT:** If removed, slide slinger washer (Ref. No. 2) onto shaft until it is located approximately 1/8" from face of motor bearing hub.

10. Slide assembled adapter and casing cover onto motor mounting face. Attach with fasteners.
11. Wet inside rubber portion of new seal head with a light coating of soapy water. Slide head onto motor shaft.
- IMPORTANT:** Reinstall any shims or spacers which may have been removed onto motor shaft before installing impeller.
12. Screw impeller back in place, tightening until it is against shaft shoulder.
13. Replace casing seal and casing. Attach with fasteners.

**IMPORTANT:** Always inspect casing seal when disassembled. Use a light oil or grease for ease of installation. Replace when cracked or worn.

### SHIM ADJUSTMENT

When installing a replacement impeller (Ref. No. 12), motor (Ref. No. 1), casing (Ref. No. 13), casing cover (Ref. No. 7), or adapter (Ref. No. 4) it may be necessary to adjust the number of shims

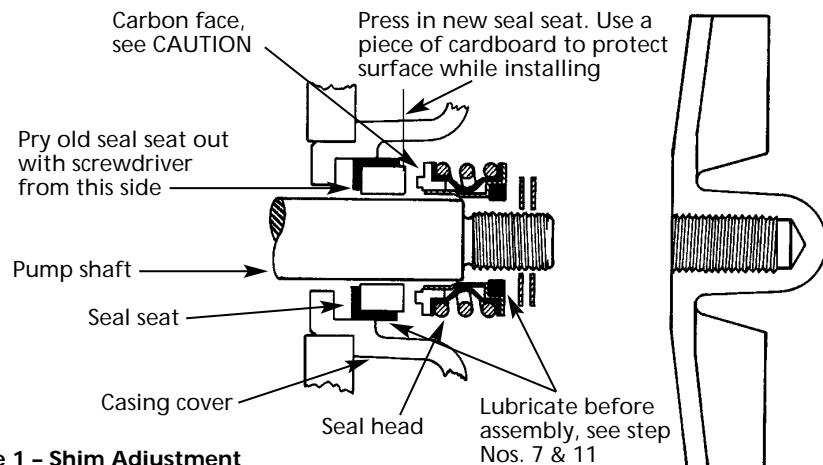

Figure 1 - Shim Adjustment



**For Repair Parts, contact dealer where pump was purchased.**

Please provide following information:

- Model number
- Serial number (if any)
- Part description and number as shown in parts list

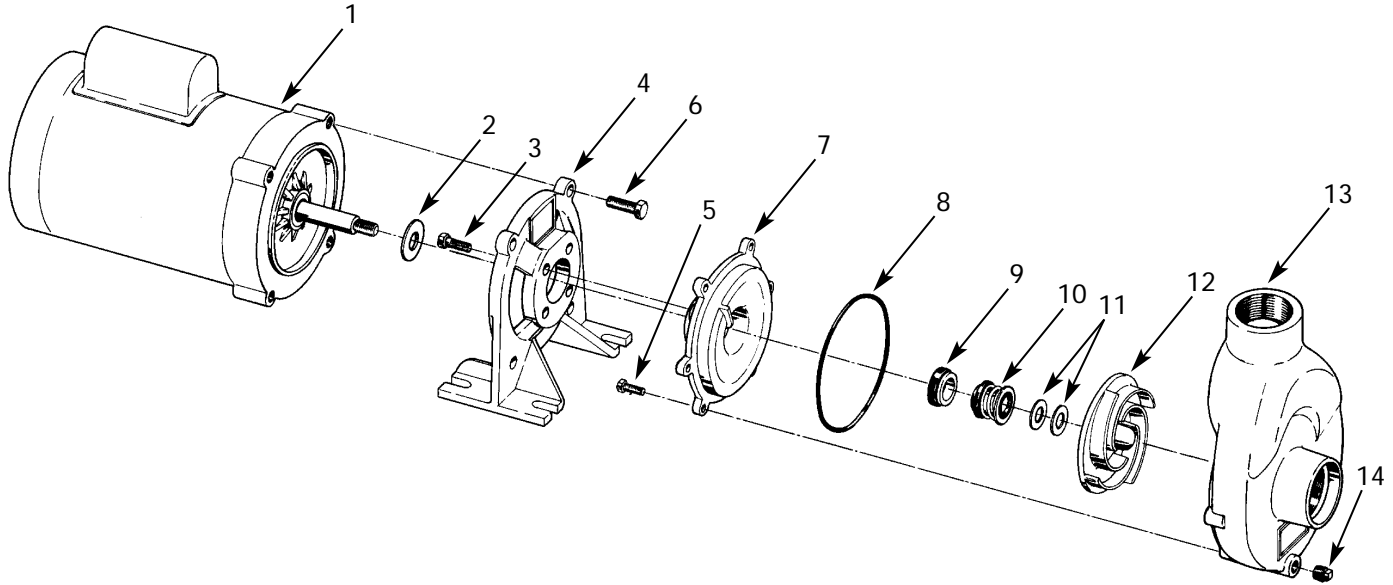

Figure 2 - Repair Parts Illustration

**Repair Parts List**

Ref. No.	Description	Part Number For Models:					Qty.
		3880-97	3881-97	3882-97	3883-97	3884-97	
1	Motor	1626-062-00	1626-063-00	1626-064-00	1626-065-00	1626-066-00	1
2	Slinger washer	1534-000-00	1534-000-00	1534-000-00	1534-000-00	1534-000-00	1
3	Fastener	*	*	*	*	*	4
4	Adapter	1993-000-01	1993-000-01	1993-000-01	1993-000-01	1993-000-01	1
5	Fastener	*	*	*	*	*	6
6	Fastener	*	*	*	*	*	4
7	Casing cover	2104-003-01	2104-003-01	2104-003-01	2104-003-01	2104-003-01	1
8	Casing seal	-Buna N (standard) 2104-004-00 -Viton (optional) 2105-023-00	2104-004-00 2105-023-00	2104-004-00 2105-023-00	2104-004-00 2105-023-00	2104-004-00 2105-023-00	1
9 & 10 ‡	Shaft seal assembly	-Buna N (optional) 1640-161-90 -Viton (optional) 1640-161-91	1640-161-90 1640-161-91	1640-161-90 1640-161-91	1640-161-90 1640-161-91	1640-161-90 1640-161-91	1
11	Shims (kit contains 0.010, 0.020 & 0.030 - 1 ea.)	1657-000-90	1657-000-90	1657-000-90	1657-000-90	1657-000-90	1
12	Impeller	2104-006-01	2104-006-02	2104-002-01	2104-015-01	2104-015-02	1
13	Casing	2104-001-01	2104-001-01	2104-001-01	2104-000-01	2104-000-01	1
14	Pipe plug	*	*	*	*	*	1

(\* Standard hardware item, available locally.

(‡ Seal assembly available as set only (includes seal head and seat).