

Please read and save this Repair Parts Manual. Read this manual and the General Operating Instructions carefully before attempting to assemble, install, operate or maintain the product described. Protect yourself and others by observing all safety information. The Safety Instructions are contained in the General Operating Instructions. Failure to comply with the safety instructions accompanying this product could result in personal injury and/or property damage! Retain instructions for future reference.

2-Inch Thermoplastic Dewatering Pumps

Refer to form 1808-633-00 for General Operating and Safety Instructions.

Description

These centrifugal pumps include a precision mechanical seal with stainless steel spring, Buna N seals, carbon face and ceramic seat, and a built-in check valve for better self-priming capabilities (up to 20 ft. suction lift). Clog resistant impeller is capable of handling solids up to 7/16" diameter. Pumps include molded carrying handle, rubber foot pads, and two 2" NPT pipe nipples. Handle liquids from 40° to 130° F (4° to 54° C). For use with nonflammable, non-abrasive liquids compatible with pump component materials.

Applications include pumping clear, clean water, salt water, and some liquid fertilizers and herbicides. An optional EPDM Seal/O-ring/Flapper Kit (see Repair Parts List) is available for pumping "Alachlor Herbicides" (such as Monsanto's Lasso). If the fertilizer or herbicide is not compatible with Buna-N (standard) or EPDM (optional) rubber materials, do not use these pumps.

Specifications

Suction inlet2" †
Discharge outlet2" †
(†) Standard NPT (female) pipe thread.

Dimensions (overall)

3824-9913 H x 15 W x 18" L
3825-9918³/₈" L x 17³/₈" W x 15¹/₄" H
382A-9918⁷/₈" L x 15⁵/₈" W x 12³/₄" H

Engine

3824-993.5 HP B&S
3825-995.5 HP B&S OHV Intek
382A-995.0 HP Honda GC OHV

Oil typeSAE 30W Detergent

Weight

3824-9938 lbs.
3825-9943 lbs.
382A-9945 lbs.

Material ...Glass-filled polypropylene

Maintenance

⚠ WARNING To prevent accidental starting always remove spark plug, or disconnect and ground spark plug wire before attempting to service or remove any component.

MECHANICAL SEAL REPLACEMENT

Refer to Figures 1, 2, and 3.

IMPORTANT: Replace seal seat, (Ref. No. 22) and seal head (Ref. No. 23) at the same time to ensure proper mating of mechanical seal components!

1. Unthread fasteners (Ref. No. 16), nuts (Ref. No. 25) and remove casing (Ref. No. 15) and casing seal (Ref. No. 7) from adapter (Ref. No. 3). Unthread fasteners (Ref. Nos. 11 and 19) and remove volute (Ref. No. 20) and volute seal (Ref. No. 6) from adapter.
2. Unthread impeller fastener (Ref. No. 10) and remove impeller (Ref. No. 9),

impeller seal (Ref. No. 4) and shims (Ref. No. 21).

NOTE: To keep shaft from turning, hold impeller while unthreading impeller fastener.

3. Pry seal seat (Ref. No. 22) from impeller recess with a screwdriver (See Figure 1).

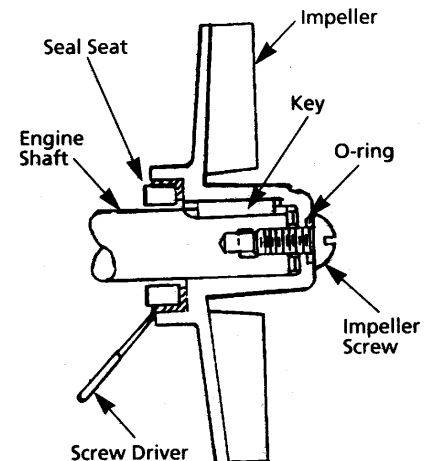

Figure 1 - Mechanical Seal Replacement

4. Remove adapter by unthreading adapter fasteners (Ref. No. 5) and fastener seals (Ref. No. 4). Press old seal head (Ref. No. 23) and adapter seal (Ref. No. 24) out of adapter by pushing from engine side.
5. Clean adapter and impeller seal recesses before installing new pieces.

Performance Chart

Model	GPH of Water at Total Head in Feet									Max. Head*
	10'	20'	30'	40'	50'	60'	70'	80'	90'	
3824-99	8460	7680	6840	6000	5100	4140	3180	2100	840	94 ft.
3825-99 & 382A-99	8460	7920	7440	6960	6360	5760	5040	4200	3360	125

(*) Shut-off; to convert to psi, divide by 2.31

2-Inch Thermoplastic Dewatering Pumps

Maintenance (Continued)

6. Carefully wipe polished surface of new seal seat with a clean cloth.
7. Wet rubber portion of seal seat with a light coating of soapy water.
8. Press seal seat squarely into recess in impeller. If seal seat does not press squarely into recess, it can be adjusted by pushing on it with a piece of pipe. Always use a piece of cardboard between pipe and seal seat to avoid scratching lapped, highly polished surface of seal seat (handle it carefully).
9. After seal seat is in place, ensure that it is clean and has not been marred.
10. Using a clean cloth, wipe shaft and make certain that it is completely clean.
11. Place adapter seal (o-ring) onto seal head behind flange and press assembly into adapter as shown in Figure 2.

▲ CAUTION *Do not touch or wipe polished face of seal head.*

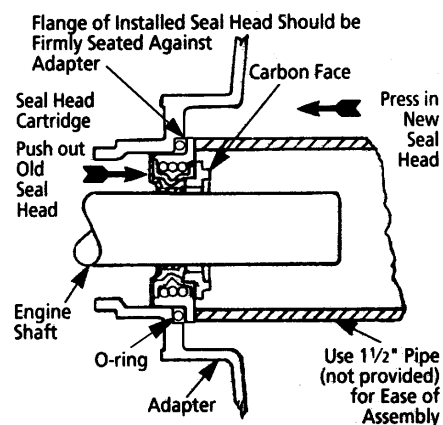

Figure 2 – Mechanical Seal Replacement

12. Secure adapter on engine mounting face, using fasteners and fastener seals. Be sure to replace gasket (Ref. No. 31) between engine and adapter, if removed during disassembly.

▲ CAUTION *Tighten adapter fasteners evenly to avoid cocking or damaging adapter.*

13. Replace impeller and shims, ensuring that key (Ref. No. 8) is in place and lock impeller to shaft with fastener and impeller seal on fastener.
14. Replace volute seal and volute with fasteners, ensure that check valve (Ref. No. 12) is in place then remount casing seal and pump casing with fasteners and nuts.

IMPORTANT: Always inspect all seals when unit is disassembled. Replace when rubber is hard, cracked, or worn.

When reassembling parts with o-ring seals or gaskets, it is sometimes helpful to apply a small amount of soapy water on o-ring so that parts slide over o-ring without pinching or shaving it.

SHIM ADJUSTMENT

When installing a replacement impeller or mechanical seal, it may be necessary to vary the number of shims (Ref. No. 21) that will be required. This is easily done by adding one 0.010" shim more than was removed, and reassembling pump as described.

Ensure that casing is snugly in place and check shaft to make sure it is turning freely. If it turns freely, check to ensure that adapter (Ref. No. 3) and casing (Ref. No. 15) are fitted tight together. If they are not, tighten fasteners (Ref. No. 16) and recheck shaft for free turning. Tighten carefully, turning shaft

while tightening. If shaft seizes before fasteners (Ref. No. 16) are completely tight, disassemble pump and remove one shim and repeat reassembly.

If any time during above operation shaft does not turn free, follow procedure indicated above and repeat procedure.

Above procedure ensures that pump will have proper running clearance (less than 0.010") between impeller and casing and perform like a new unit with new impeller or motor.

For Replacement Parts, contact dealer where pump was purchased.

Please provide following information:

- Model number
- Serial number (if any)
- Part description and number as shown in parts list

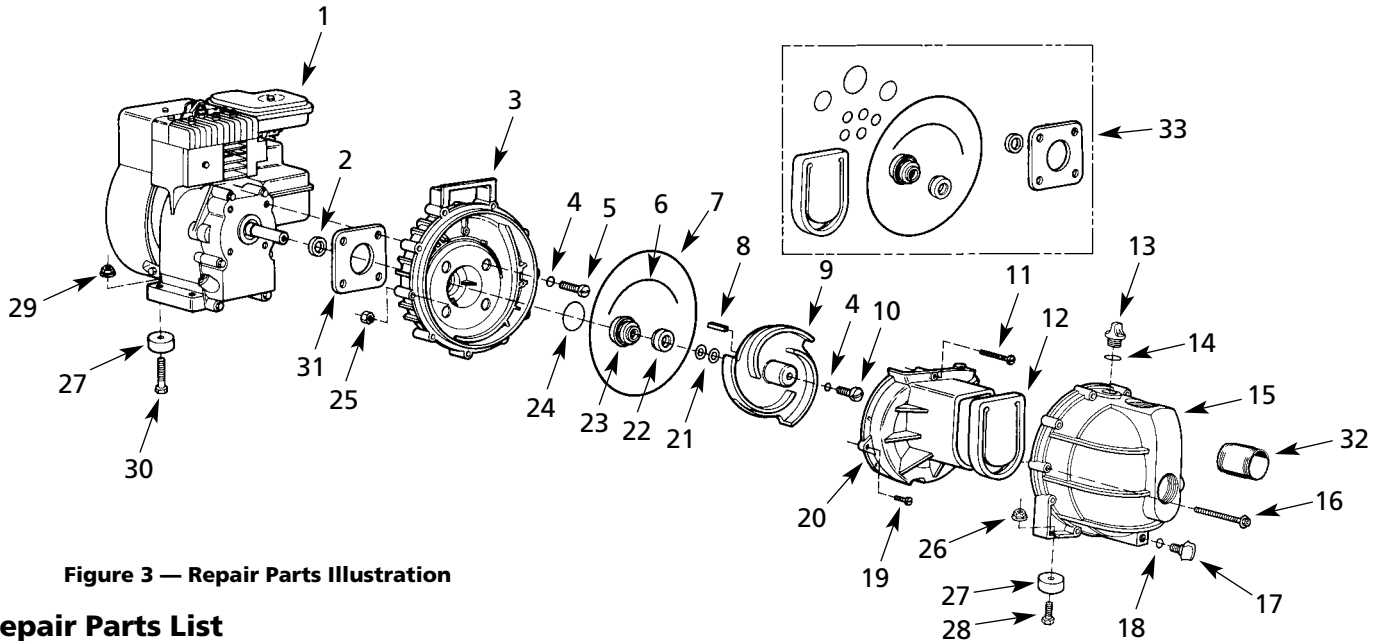

Figure 3 — Repair Parts Illustration

Repair Parts List

Ref. No.	Description	3 1/2 HP B&S 3824-99	5 1/2 HP B&S 3825-99	5HP Honda 382A-99	Qty.
1	Engine	1632-031-00	1639-014-00	1639-040-00	1
2	Slinger washer -Buna-N	2102-000-00	2102-000-00	2102-000-00	1
3	Adapter	3827-033-00	3827-033-00	3827-033-00	1
4	Fastener seal -Buna-N	*	*	*	5
5	Adapter fastener	1753-002-00	1753-002-00	1753-002-00	4
6	Volute seal -Buna-N	*	*	*	1
7	Casing seal -Buna-N	*	*	*	1
8	Key	1517-000-00	1517-000-00	1517-000-00	1
9	Impeller	3827-012-00	3827-013-00	3827-013-00	1
10	Impeller fastener	1753-001-00	1753-001-00	1753-001-00	1
11	Volute fastener	1707-003-00	1707-003-00	1707-003-00	1
12	Flapper valve -Buna-N	3827-070-00	3827-070-00	3827-070-00	1
13	Fill plug	3827-176-00	3827-176-00	3827-176-00	1
14	Fill plug seal -Buna N	*	*	*	1
15	Casing	3827-004-00	3827-004-00	3827-004-00	1
16	Fastener	*	*	*	10
17	Drain plug	3827-177-00	3827-177-00	3827-177-00	1
18	Drain plug seal -Buna N	*	*	*	1
19	Volute fastener	1707-002-00	1707-002-00	1707-002-00	2
20	Volute	3827-151-00	3827-151-00	3827-151-00	1
21	Impeller shim set (.005, .015, .030; one each)	3827-172-90	3827-172-90	3827-172-90	1
22 & 23	Shaft seal assembly -Buna N	1640-162-95	1640-162-95	1640-162-95	1
24	Adapter seal -Buna N	*	*	*	1
25	Nut	*	*	*	10
26	Nut	*	*	*	2
27	Rubber foot	1508-000-00	1508-000-00	1508-000-00	4
28	Fastener	*	*	*	2
29	Nut	*	*	*	2
30	Fastener	*	*	*	2
31	Gasket	2102-002-00	2102-002-00	2102-002-00	1
32	2" NPT Pipe nipple	*	*	*	2
33	† Seal kit -Buna N (standard)	3827-300-91	3827-300-91	3827-300-91	1
	† Seal kit -EPDM (optional)	3827-301-91	3827-301-91	3827-301-91	

(*) Standard hardware item, available locally.

(†) Includes all required seals, Ref. Nos. 2, 4, 6, 7, 12, 14, 18, 22, 23, 24, 31.

