



Straight Centrifugal Pedestal Pumps

- Available in: Investment Cast 316 Stainless Steel, Cast Bronze or Stainless Steel Fitted Cast Iron Construction (See Specification Section for Specific Model Availability)
- Mechanical Seal

Stainless Steel	Viton®
Cast Bronze	Buna N
Stainless Steel Fitted Cast Iron	Viton®
- Optional Silicon Carbide Seals Available
- 3/4" to 1-1/2" NPT Suction Ports
- 1/2" to 1-1/4" NPT Discharge Ports
- Maximum Temperature

Buna N	180° F
Viton®	200° F
- Maximum 4000 RPM
- High Head Models 4897 & 4906 for High Pressure/Booster Applications
- General Service Models 3682, 3694 & 3704 for Low Pressure Applications

AMT Straight Centrifugal Pedestal pumps are designed for continuous-duty OEM, Industrial/Commercial and processing applications including circulation, chemical processing, liquid transfer, heating and cooling. The high head models are ideal for sprinkler systems and pressure boosting.

These units are available in a variety of construction and seal materials. Pull-from-the-rear design permits easy servicing without disturbing any piping. Pedestals feature CNC machined shafts with sealed ball bearings. Models 4897 and 4906 pedestal drive are epoxy coated and include 304 stainless steel shafts.

AMT Straight Centrifugal Pedestal pumps are reliable, cost effective and low maintenance. For use with non-flammable liquids compatible with pump component materials.

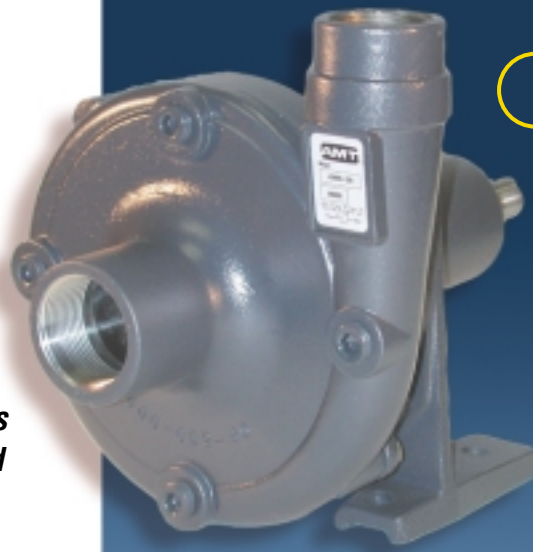

High Head Pedestal



Straight Centrifugal Pedestal

Performance of Straight Centrifugal Pedestals

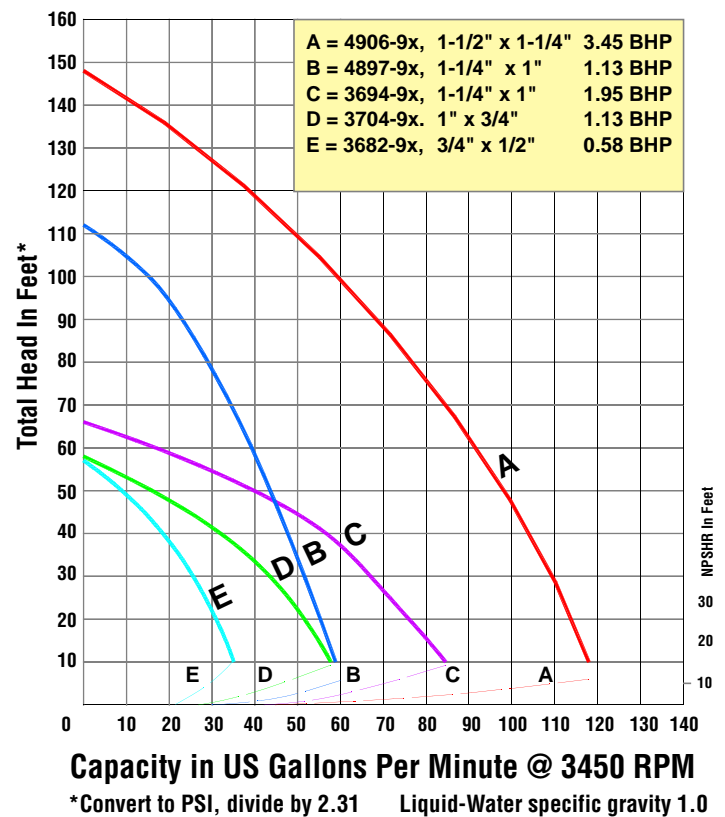

Straight Centrifugal Pedestal Pumps

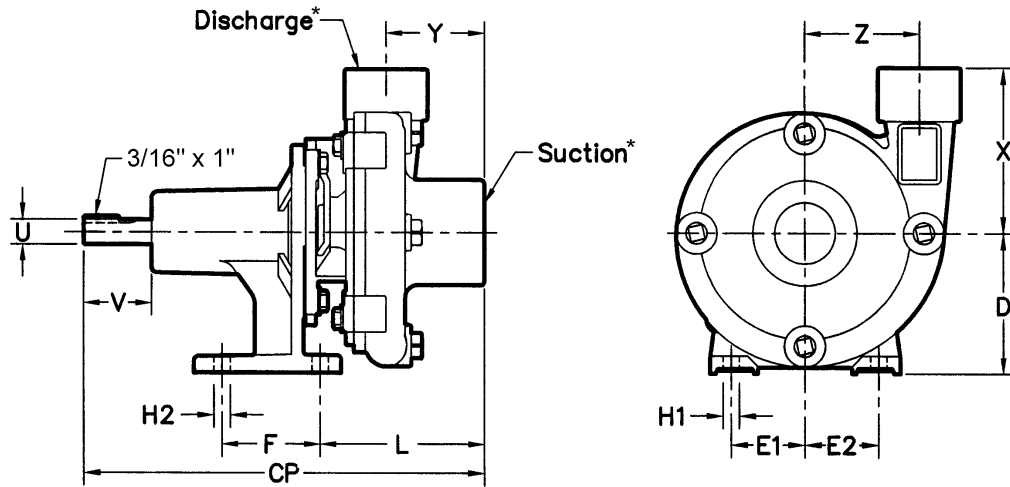

Pump Dimensional Data

Model No.	SUC*	DIS*	CP	D	E1	E2	F	H1	H2	L	U	V	X	Y	Z	Min. BHP Required @3450 RPM	(-95) Cast Iron Ship Wt.	(-97) Bronze Ship Wt.	(-98) S. Steel Ship Wt.
GENERAL SERVICE MODELS																			
3682-9x	3/4"	1/2"	6.6	3.2	1.5	1.5	N/A	0.3	0.3	3.0	0.6	1.3	1.9	1.4	1.9	0.58	9 Lbs.	10 Lbs.	9 Lbs.
3704-9x	1"	3/4"	6.7	3.2	1.5	1.5	N/A	0.3	0.3	3.0	0.6	1.3	2.4	1.4	2.1	1.13	10 Lbs.	11 Lbs.	10 Lbs.
3694-9x	1-1/4"	1"	6.7	3.2	1.5	1.5	N/A	0.3	0.3	3.0	0.6	1.3	2.5	1.3	2.0	1.95	12 Lbs.	13 Lbs.	12 Lbs.
HIGH HEAD MODELS																			
4897-9x	1-1/4"	1"	11.5	4.2	2.2	2.2	3.0	0.5	0.5	4.4	0.7	1.9	4.8	2.1	3.3	1.13	34 Lbs.	38 Lbs.	34 Lbs.
4906-9x	1-1/2"	1-1/4"	12.1	4.2	2.2	2.2	3.0	0.5	0.5	4.9	0.7	1.9	4.9	3.0	3.5	3.45	36 Lbs.	40 Lbs.	36 Lbs.

(* Standard NPT (female) pipe thread.
NOTE: Dimensions have a tolerance of $\pm 1/8$ ".

When Ordering Add the Correct-9x Suffix to Model Number Indicating Material Selection

XCI (-95)=Cast Iron Construction with SS Impeller and Buna N Seals, Max. Temperature 180°F

XB (-97)=All Cast Bronze Construction with Viton® Seals, Max. Temperature 200°F

XSS (-98)=All 316 Stainless Steel Construction with Viton® Seals, Max. Temperature 200°F

Standard Features

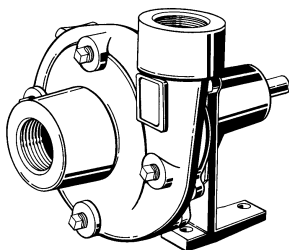

400 Spring Street
Royersford, PA 19468
(610) 948-3800 Fax (610) 948-5300
E-mail: amt@fast.net
www.amtpump.com

- ▶ **Stainless Steel** Fitted Cast Iron, Cast Bronze or Investment Cast 316 **Stainless Steel** Construction
- ▶ 3/4" to 1-1/2" NPT Suction Ports
- ▶ 1/2" to 1-1/4" NPT Discharge Ports
- ▶ Maximum Working Pressure

General Service	75 PSI
High Head	150 PSI
- ▶ Self-cleaning Impellers on General Service Models
- ▶ Maximum Temperature

Buna N	180° F
Viton®	200° F
- ▶ Maximum Flow 118 GPM
- ▶ Maximum Head 148 Ft.
- ▶ Discharge Port Rotates in 90° Increments on High Head Units
- ▶ Epoxy Coated Pedestal Drive on High Head Models