

Please read and save this Repair Parts Manual. Read this manual and the General Operating Instructions carefully before attempting to assemble, install, operate or maintain the product described. Protect yourself and others by observing all safety information. The Safety Instructions are contained in the General Operating Instructions. Failure to comply with the safety instructions accompanying this product could result in personal injury and/or property damage! Retain instructions for future reference. AMT reserves the right to discontinue any model or change specifications at any time without incurring any obligation.

©2012 American Machine & Tool Co., Inc. of PA, A Subsidiary of The Gorman-Rupp Company, All Rights Reserved.

Periodic maintenance and inspection is required on all pumps to insure proper operation. Unit must be clear of debris and sediment. Inspect for leaks and loose bolts. Failure to do so voids warranty.

# 3-Inch Solids-Handling Pedestal Pump

Refer to pump manual 1808-635-00 for General Operating and Safety Instructions.

## DESCRIPTION

These high capacity, heavy-duty self-priming (to 20 ft. lift) pumps, are designed for direct coupling drive or pulley drive. Each pump is equipped with a clog-resistant cast iron impeller capable of handling solids up to 3/4" diameter. Pump is designed for operations involving irrigation and dewatering of excavations basements etc. handles liquids from to to . or use with nonflammable non-abrasive liquids compatible with pump component materials.

## SPECIFICATIONS

Suction Inlet.....	3" NPT
Discharge Outlet.....	3" NPT
Shaft Diameter.....	1/8"
Keyway.....	1 / 1 / 1/4"
Dimensions	
(Overall).....	L 1/2" W 1/2" 3"
Weight.....	6 lbs.
Seals.....	339 -99 – Buna-N with carbon/ceramic faces
.....	339 -V9 – Viton with carbon/ceramic faces

## MAINTENANCE

### **▲ WARNING**

*Make certain that unit is disconnected from power source before attempting to service or remove any components! If power disconnect is out-of-sight, lock it in open position and tag to prevent application power.*

## MECHANICAL SEAL REPLACEMENT

Refer to Figures 1 and 2

**IMPORTANT:** Always replace seal seat (Ref. No. 7), seal head (Ref. No. 6), and shaft sleeve (Ref. No. 5) to insure proper mating of mechanical seal components!

1. Remove pump casing (Ref. No. 2), casing seal (Ref. No. 8) and impeller (Ref. No. 3)

**NOTE:** Mechanical shaft seal consists of 2 faces, one stationary (seat) and other rotating (head). When removing seal refer to Figure 2, and carefully note position of seal faces and how they fit one to the other. Seat is installed in adapter (Ref. No. 9) and head (located around shaft) rides up against seat. The purpose of rubber components is to seal parts to housings and shaft and/or shaft sleeve. The purpose of stainless steel spring is to maintain pressure of carbon face to ceramic face.

## Performance Chart

Pump Speed RPM	Elec. Motor*		Sheave			GPM at Total Head in Feet										Max Head
	HP	RPM	Motor PD	Pump PD	No. of Grooves	10'	20'	30'	40'	50'	60'	70'	80'	90'		
1725	1 1/2	1800	3. "	3. "	1	6,600	3,120	-	-	-	-	-	-	-	23 ft.	
	1 1/2	3600	.5"	5. "	1											
2800	5	1800	5.5"	3.5"	2	13,500	12,000	10,140	8,160	5,280	840	-	-	-	61 ft.	
	5 1/2	3600	3.5"	.5"	2											
3450	7 1/2	1800	7. "	3.5"	2	17,100	15,900	14,700	13,200	11,460	9,900	7,800	5,100	1,500	92 ft.	
	7 1/2	3600	3.5"	3.5"	2											

Note: RPM listed are synchronous, actual RPM is very close to 3450 for 3600 and 1725 for 1800.

(\*) Minimum electric motor HP required.

# 3-Inch Solids-Handling Pedestal Pump

## MAINTENANCE (Continued)

2. Remove shaft sleeve with sea head on it. Separate seal head from sleeve.
3. Remove adapter from bearing housing (Ref. No. 12), then using two screwdrivers or other suitable tools, remove seal seat from adapter.
4. Thoroughly clean all surfaces of seal seat cavity.
5. Using a clean cloth, wipe shaft and shaft sleeve and make certain that they are perfectly clean.

**NOTE:** Do not touch or wipe polished face of seal head.

6. Wet rubber portion of new seal seat with light coating of soapy water. Press seal seat squarely into adapter recess. Avoid scratching polished surface.

**NOTE:** Handle all seal parts with extreme care and attention to keeping them clean. Do not touch polished faces with your hands. Do not put lubricants of any kind on seal faces; this can cause seal to leak.

7. Inspect polished face of seal seat and polished face of seal head to insure they are clean and not marred.
8. Wet inside rubber portion of new seal head with a light coating of soapy water. Slide head onto shaft sleeve.

**IMPORTANT:** Before installing new shaft sleeve, apply a bead of non-hardening, pliable sealant (such as Permatex® Form-A-Gasket® No. 2) to motor shaft shoulder.

**NOTE:** Reinstall any shims or spacers, which may have been removed, onto pedestal shaft before installing impeller.

9. Screw impeller back in place, tightening until it is against shaft shoulder.
10. Replace adapter, gasket and casing and fasten with eight cap screws.
11. After assembly, turn shaft by hand slowly to check for striking of impeller on casing. If striking or rubbing occurs, adjust impeller shims (see Shim Adjustment) as required.
12. A short "run-in" period may be necessary to provide completely leak free seal operation.

## IMPELLER REPLACEMENT

Impeller (Ref. No. 3) is subject to wear only by abrasive action of sandy or dirty fluid. If badly worn, all these parts can be replaced easily, and pump thus restored to like-new operation.

**NOTE:** When clearance between impeller exceeds  $\frac{1}{6}$ " at face of impeller or  $\frac{1}{8}$ " on outside diameter of impeller, it may be necessary to take corrective action. The increased clearance can cause lengthened priming times and reduced pumping capacity. If both priming and capacity of your unit are satisfactory for your application, it is recommended that no corrective maintenance be performed regardless of what clearances on your unit may be developed, since the increased clearances in themselves are not generally harmful to your pump. Normally, new pump clearances can be restored by simply shimming behind impeller. (Add shim washers Ref. No. 4)

If diameter of impeller is badly worn or if shim washers do not restore clearances to less than  $\frac{1}{6}$ " face dimension required it is recommended that impeller be replaced.

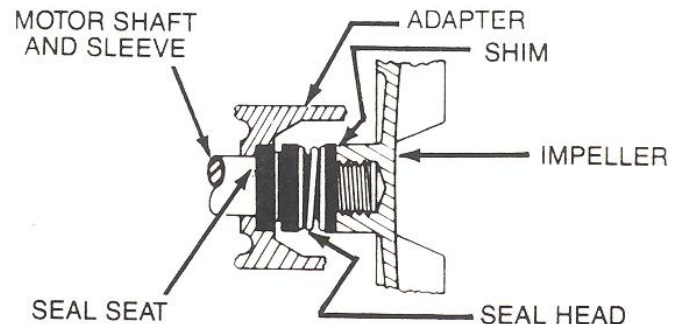

Figure 1- Mechanical Seal Replacement

## BEARING HOUSING SERVICE

1. Remove front pump assembly as described under "Mechanical Seal Replacement."
2. Remove shaft bearing (Ref. No. 15) and shaft (Ref. No. 16) as an assembly by first removing snap ring (Ref. No. 18). Push shaft bearing assembly out of bearing housing (Ref. No. 12) by rapping on threaded end of shaft with a rawhide mallet, or block of wood and hammer.
3. Ball bearings can now be removed from shaft.
4. If shaft bearings have been removed from shaft, replace by sliding bearing on shaft to shoulder. Replace shaft bearing assembly by sliding assembly into housing threaded end first. Push shaft bearing assembly completely in by gently tapping on keyway end of shaft with a rawhide mallet. Replace snap ring.
5. Reassemble pump as described in "Mechanical Seal Replacement."

## SHIM ADJUSTMENT

1. When installing a replacement impeller (Ref. No. 3) it may be necessary to vary number of shims (Ref. No. 4) that will be required. This is done by adding one shim more than was removed and reassembling pump as described.
2. Insure that casing is snugly in place and check shaft to make sure it is turning freely. If it turns freely, check to insure that adapter (Ref. No. 9) and casing (Ref. No. 2) are fitted metal to metal where they meet on outside. If they are not metal to metal, tighten cap screw (Ref. No. 10) and recheck shaft for free turning. Tighten carefully, turning shaft while tightening. If shaft seizes before cap screw are completely tight, disassemble pump and remove one shim and repeat reassembly.
3. If at any time during above operation shaft does not turn free or a metal to metal strike can be heard or felt when turning shaft, follow procedure indicated above and repeat procedure.
4. Above procedure insures that pump will have proper running clearance between impeller and casing and perform like a new unit.

## For Repair Parts contact dealer where pump was purchased.

Please provide following information:

-Model Number

-Serial Number (if any)

Part description and number as shown in parts list

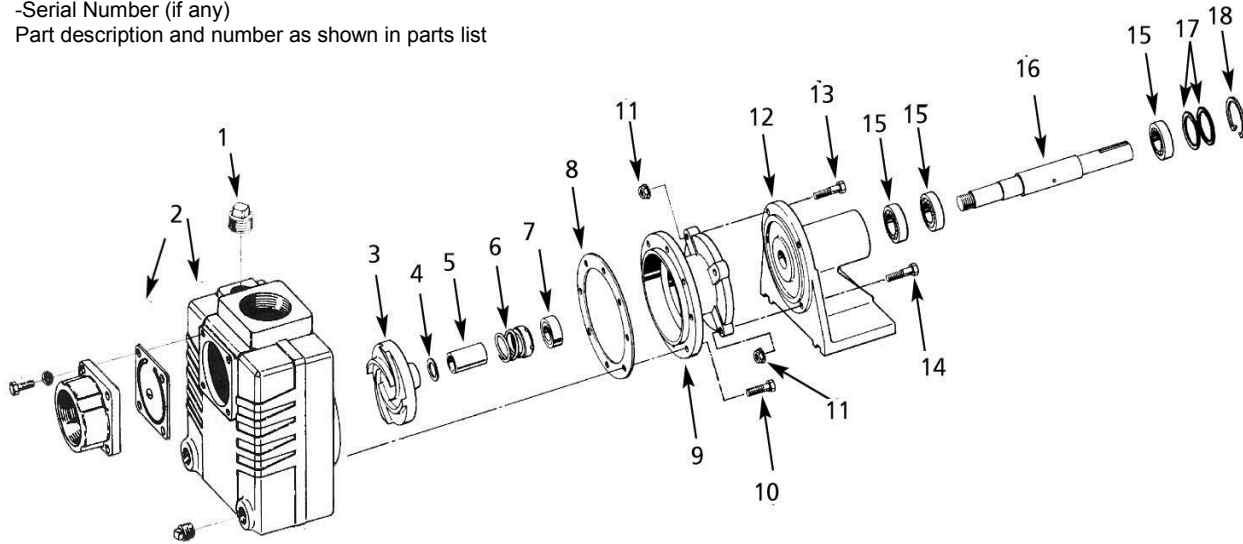

Figure 2 – Repair Parts Illustration

## Repair Parts List

Ref. No.	Description	Part Number for Models:		Qty.
		3391-99	3391-V9	
1	3/4" NPT Drain Plug	*(Incl. w/ Ref. 2)	*(Incl. w/ Ref. 2)	3
2	Casing Kit with Buna Flapper	3270-003-95	N/A	1
	Casing Kit with Viton Flapper	N/A	3270-002-95	1
3	Impeller Kit	2870-010-95	2870-010-95	1
	(includes Ref. Nos. 3 & 4)			
4	Impeller Shim Package	1656-000-90	1656-000-90	1
5	Shaft Sleeve (See Ref. No. 9)	1555-140-03	1555-140-03	1
6 & 7	Seal Assembly - Buna-N	1640-163-90	N/A	1
	Seal Assembly - Viton	N/A	1640-163-91	1
8	Gasket	1546-000-00	1546-000-00	1
9	Adaptor Kit	3391-030-95	3391-030-95	1
10	5/16" - 18 UNC x 3/4" Washer Base Hex Head Cap Screw	*(Incl. w/ Ref. 2)	*(Incl. w/ Ref. 2)	8
11	3/8" - 16 Washer Base Hex Nut	*(Incl. w/ Ref. 9)	*(Incl. w/ Ref. 9)	4
12	Bearing Housing	1695-054-01	1695-054-01	1
13	3/8" - 6 UN 3/4" Hex Head Cap Screw	*(Incl. w/ Ref. 9)	*(Incl. w/ Ref. 9)	2
14	3/8" - 16 UNC x 2" Hex Head Cap Screw	*(Incl. w/ Ref. 9)	*(Incl. w/ Ref. 9)	2
15	Ball Bearing	1695-056-00	1695-056-00	3
16	Shaft Assembly	1695-060-00	1695-060-00	1
17	Bearing Shim Package	1695-020-90	1695-020-90	1
	(includes: (1) 0.005", (1) 0.010", (1) 0.20")			
18	Snap Ring	1695-057-00	1695-057-00	1
↔	Shaft Key	1695-039-00	1695-039-00	1

(\*) Standard Hardware Item, Available Locally

(↔) Not Shown.



American Machine & Tool Co., Inc. of PA  
(herein "AMT")  
400 Spring Street  
Royersford, PA 19468  
Phone: (610) 948-3800  
Fax: (610) 948-5300  
www.amtpump.com

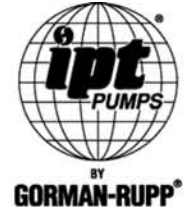

## General Information

**SALES POLICY:** AMT products are sold through our established Distributors. We do not sell direct to the consumer or organization not entitled to trade recognition. Therefore, possession of our catalogs and/or price list(s) does not infer an offer to sell.

**MINIMUM ORDER:** We appreciate your order, however, all orders are subject to a minimum \$35.00 net invoice charge (excluding freight). This applies to all pump and parts purchase orders.

**PRICES:** Prices are subject to change without notice. All orders accepted are subject to prices in effect at time of shipment.

**PAYMENT TERMS:** Terms, upon establishment of credit, are Net 30 days. Past due accounts may be subject to a service charge of 1.5% per month. Domestic or assignable letter of credit is required for all export trade.

**PAST DUE ACCOUNTS:** AMT reserves the right to withhold open account shipments on any past due account. Invoices are considered past due after thirty (30) days. In the interest of sound business, all orders are subject to approval of the Credit Department.

**SHIPPING INSTRUCTIONS:** All shipments will be made F.O.B. the factory. Where instructions for shipment do not appear on the order, the shipment will be made according to our best judgment. Full risk of loss (including transportation delays and losses) shall pass to the customer upon delivery of the products to the carrier at the F.O.B. point. When loss or delay occurs, primary responsibility for tracing rests with the customer. When there is LOSS or APPARENT VISIBLE DAMAGE to a shipment, when tendered for delivery, **DO NOT** give the carrier a clear receipt. Note such damage on the carrier's delivery receipt and **HAVE THE DRIVER SIGN THE RECEIPT.**

**PRODUCT REVISIONS:** AMT reserves the right to discontinue, change or improve its products or any portions thereof without being obligated to provide such a change or improvement for units sold and/or shipped prior to such a change or improvement.

## 12 Month Limited Warranty

### EXTENT AND DURATION OF LIMITED WARRANTY

**Coverage:** American Machine & Tool Company (herein "AMT") or IPT Pumps by Gorman-Rupp (herein "IPT") or Gorman-Rupp Industries Division of The Gorman-Rupp Company, Patterson, or the Gorman-Rupp Company (herein referred to as "G-R Unit") each individually warrants that its products and parts shall be free from defects in material and workmanship for twelve (12) months from the date of purchase by the original end user when installation is made and maintenance is performed in accordance with G-R Unit's recommendations. Wear and tear resulting from use and items normally consumed in use are not covered.

### EXCEPTIONS

( A ) This Limited Warranty shall not apply to mechanical seals in AMT or IPT pumps and the following products and parts: engines, motors, trade accessories and all other products, components, parts and materials not manufactured by the G-R Units. These items may, however, be covered by the warranties of their respective manufacturers. ( B ) This warranty does not extend to or apply to any unit which has been repaired or altered at any place other than by a G-R Unit, or by persons not expressly approved by a G-R Unit to make repairs or alterations, nor to any unit the serial number, model number or identification of which has been removed, defaced or altered. ( C ) This warranty does not extend to any product manufactured by a G-R Unit, which has been subjected to mis-use, neglect, accident, improper installation, or use in violation of instructions furnished by a G-R Unit. ( D ) Pump Kits: This warranty does not extend to any product sold by a G-R Unit unassembled as a Pump Kit. Pump Kits are warranted against defects in material and workmanship for 60 days from the date of shipment from a G-R Unit. Any Pump Kit parts deemed defective by a G-R Unit will be replaced free of charge within 60 days of shipment. Pump Kits are not returnable for credit.

### LIMITATIONS

**THE G-R UNITS' SOLE AND EXCLUSIVE WARRANTY WITH RESPECT TO THEIR PRODUCTS AND PARTS IS THIS LIMITED WARRANTY. THIS LIMITED WARRANTY IS IN LIEU OF ALL OTHER EXPRESS AND/OR IMPLIED WARRANTIES, INCLUDING IMPLIED WARRANTIES OF MERCHANTABILITY AND FITNESS FOR PARTICULAR PURPOSE.**

### EXCLUSIVE REMEDY AND DAMAGES

The sole and exclusive remedy for breach of this Warranty by a G-R Unit and the entire extent of its liability for such breach or for damages arising from the use of the products and parts covered under this Limited Warranty, shall be as follows:

**LEAD TIME:** Products designated "Quick Ship Product", also referred to as "QSP" will normally be shipped within 24 hours of receipt of a non-cancellable purchase order. Only limited quantities of "QSP" pumps are available.

**STANDARD LEAD TIME:** Lead time is two weeks for all non "QSP" product. AMT reserves the right to revise lead times as required due to availability of materials and all other causes beyond our control.

**VIP SHIPMENT:** Select AMT and IPT branded pumps are available for next day shipment for non-QSP (Quick Ship Products) items and subjected to a specific model surcharge per unit noted in the respective price book. Requires calling for availability, confirmation and a non-cancellable purchase order or credit card payment prior to shipment. The expedited shipping charges are an additional cost added separately from the VIP charges per item. AMT reserves the right to revise lead times as required due to availability of materials and all other causes beyond our control. QSP quantities are limited as determined by AMT.

ALL purchase orders must be submitted via hard copy sent to AMT customer service department by fax, EDI or e-mail.

**RETURN GOODS POLICY:** Goods shall not be returned without a return goods authorization number (RGA) issued by AMT customer service. The RGA number must be listed on the packing list. Only current model and part numbers with a valid date code may be returned (within one year from date of purchase). **A 20% restocking and packaging charge will apply to all returns. All shipping charges must be pre-paid. No exceptions.**

**ORDER CHANGES BY CUSTOMER:** Orders in process may not be changed except with written consent and may be subject to special charges.

- 1. Repair or Replacement:** If inspection shows that any G-R Unit product or part covered under this Limited Warranty is defective in materials or workmanship, the G-R Unit shall repair or replace the defective or non-conforming product or part without charge, whichever the G-R Unit chooses. You must have properly maintained and used the product or part claimed to be defective in accordance with the maintenance schedule or manual, which comes with the product. No allowance will be made for labor, installation, removal, transportation or other charges incurred by you in connection with such repair or replacement.
- 2. To obtain the above remedy:**
  - A.** Immediately notify the G-R Unit upon discovery of the claimed defect in materials or workmanship and provide the serial number or date code of the product and/or part(s) or provide the G-R Unit with the invoice or bill of sale referencing the product by no later than the expiration date of the warranty period.
  - B.** The G-R Unit will advise whether inspection will be necessary and how whether repair or replacement will be made. If inspection by the G-R Unit is necessary, the pump or defective part must be sent freight pre-paid to the G-R Unit. Return shipment will be F.O.B. the G-R Unit's plant.
  - C. Return Goods Authorization Requirement:** No product will be accepted for return or replacement without the prior written authorization of the G-R Unit. Upon such authorization, and in accordance with instructions from the G-R Unit, the product will be returned to the G-R Unit, shipping charges prepaid by the Buyer.
- 3. Damages:** The G-R Unit's liability for damages for breach of this Limited Warranty shall not exceed the amount of the purchase price of the product or part(s) in respect to which Such damages are claimed. **IN NO EVENT SHALL THE G-R UNITS BE LIABLE FOR INCIDENTAL, CONSEQUENTIAL OR SPECIAL DAMAGES FOR BREACH OF THIS LIMITED WARRANTY.**

Some states do not allow the exclusion or limitation of incidental or consequential damages, so the above limitation or exclusion may not apply to you. This Limited Warranty gives you specific legal rights, and you may also have other rights, which vary from state to state.