

# Self-Priming Diaphragm Pumps



Model 335H-96



Model 336G-96



Model 335Z-96\*

\*Shown with 90° Rotatable Base

- **Sand Cast Aluminum Construction for Portability and Durability**
- **Thermoplastic Santoprene Diaphragm**
- **2" or 3" NPT Suction and Discharge Ports**
- **Maximum Solids Handling up to 1-5/8"**
- **Modular Component Design Permits Easy Maintenance and Cleanout**
- **Driver Options: Gasoline, Diesel or Electric Single & Three Phase Motors**
- **Delivers up to 90 GPM**
- **90° Rotatable Base on All Models**

The AMT line of Diaphragm pumps features a 2-stage, heavy duty forged gear driven transmission. Often referred to as Mud or Sludge Pumps, diaphragm pumps are designed to pump mud, slurry, sewage and thick liquids that have the ability to flow. AMT Diaphragm pumps are available with a choice of drivers to meet your application requirements: gasoline, diesel or single or three phase electric motor. Built-in check valve assures self-priming to 20 feet after initial prime. Heavy duty forged gear driven transmission is designed to operate pump at 40 strokes per minute for electric motor models and 60 strokes per minute for engine driven models. Each unit includes a 2" or 3" NPT steel suction strainer, two NPT nipples and a wheel kit for portability. Models 336E-K6, 336G-K6, 335G-K6 and 335E-K6 are kits provided less motor or engine. **Suction and discharge port sizes cannot be reduced.**

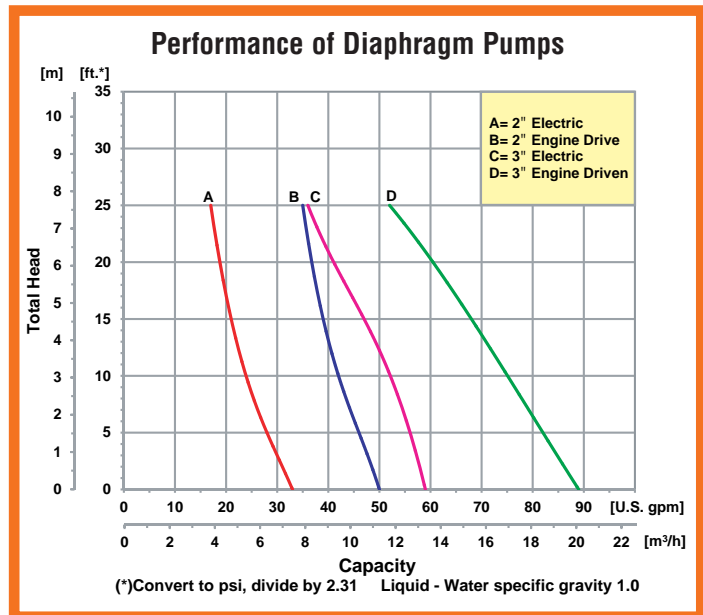

400 Spring Street • Royersford, PA 19468 USA

[www.amtpump.com](http://www.amtpump.com) • 888-amt-pump (268-7867)

For use with nonflammable liquids compatible with pump component materials. Viton® and Teflon® are registered trademarks of E. I. DuPont.

## 2" Self-Priming Diaphragm Pumps

| Model                | Curve | Driver                             | Run Time (Hours) | Tank Size (Gal/Ltr.) | Ship Wt. (Lbs.) |
|----------------------|-------|------------------------------------|------------------|----------------------|-----------------|
| 336G-96              | A     | Honda GX120 <sup>▲</sup>           | 2.0              | 0.52/2.0             | 160             |
| 336G-K6              | A     | Kit, Less Engine                   | 2.0              | N/A                  | 95              |
| 336E-96 <sup>◊</sup> | B     | 1.5 HP Electric Motor <sup>◊</sup> | N/A              | N/A                  | 165             |
| 336E-K6              | B     | Kit, Less Engine                   | N/A              | N/A                  | 95              |

Maximum Solids Handling Capacity: 1-1/4" Diameter

| Model                | SUC* | DIS* | L**          | W           | H           |
|----------------------|------|------|--------------|-------------|-------------|
| 336G-96              | 2"   | 2"   | 43.8 [111.2] | 22.2 [56.3] | 27.5 [69.8] |
| 336G-K6              | 2"   | 2"   | N/A          | 22.2 [56.3] | 27.5 [69.8] |
| 336E-96 <sup>◊</sup> | 2"   | 2"   | 43.8 [111.2] | 22.2 [56.3] | 27.5 [69.8] |
| 336E-K6              | 2"   | 2"   | N/A          | 22.2 [56.3] | 27.5 [69.8] |

336E/335E-96 Motors: 115/208-230 VAC, 1 Phase, 14 Amp, 60 Hz;  
110/220 VAC 50 Hz, 17 Amps

## 3" Self-Priming Diaphragm Pumps

| Model                | Curve | Driver                             | Run Time (Hours) | Tank Size (Gal/Ltr.) | Ship Wt. (Lbs.) |
|----------------------|-------|------------------------------------|------------------|----------------------|-----------------|
| 335G-96              | C     | Honda GX120 <sup>▲</sup>           | 2.0              | 0.52/2.0             | 175             |
| 335A-96              | C     | Briggs & Stratton                  | 1.5              | 0.52/2.0             | 175             |
| 335H-96              | C     | Honda GX160 <sup>▲</sup>           | 2.5              | 0.82/3.1             | 185             |
| 335Z-96              | C     | Hatz Diesel 1B20                   | 2.7              | 0.79/3.0             | 205             |
| 335G-K6              | C     | Kit, Less Engine                   | N/A              | N/A                  | 145             |
| 335E-96 <sup>◊</sup> | D     | 1.5 HP Electric Motor <sup>◊</sup> | N/A              | N/A                  | 185             |
| 335E-K6              | D     | Kit, Less Engine                   | N/A              | N/A                  | 145             |

| Model                | SUC* | DIS* | L**          | W           | H           |
|----------------------|------|------|--------------|-------------|-------------|
| 335G-96              | 3"   | 3"   | 42.0 [106.6] | 30.0 [76.2] | 22.0 [55.8] |
| 335A-96              | 3"   | 3"   | 41.5 [105.4] | 30.0 [76.2] | 22.0 [55.8] |
| 335H-96              | 3"   | 3"   | 41.5 [105.4] | 30.0 [76.2] | 22.0 [55.8] |
| 335Z-96              | 3"   | 3"   | 43.8 [111.2] | 30.0 [76.2] | 22.0 [55.8] |
| 335G-K6              | 3"   | 3"   | N/A          | 30.0 [76.2] | 23.2 [59.8] |
| 335E-96 <sup>◊</sup> | 3"   | 3"   | 43.5 [110.4] | 30.0 [76.2] | 22.0 [55.8] |
| 335E-K6              | 3"   | 3"   | N/A          | 30.0 [76.2] | 23.2 [59.8] |

(\*) Standard NPT (Female) pipe thread.

(\*\*) This dimension may vary due to engine manufacturer's specifications.

NOTE: Dimensions are in inches (centimeters) and have a tolerance of  $\pm 1/8"$ .

Construction: Sand Cast Aluminum

▲ Oil Alert Included

◊ Special Order 3 Phase Version Available

Maximum Solids Handling Capacity: 1-5/8" Diameter

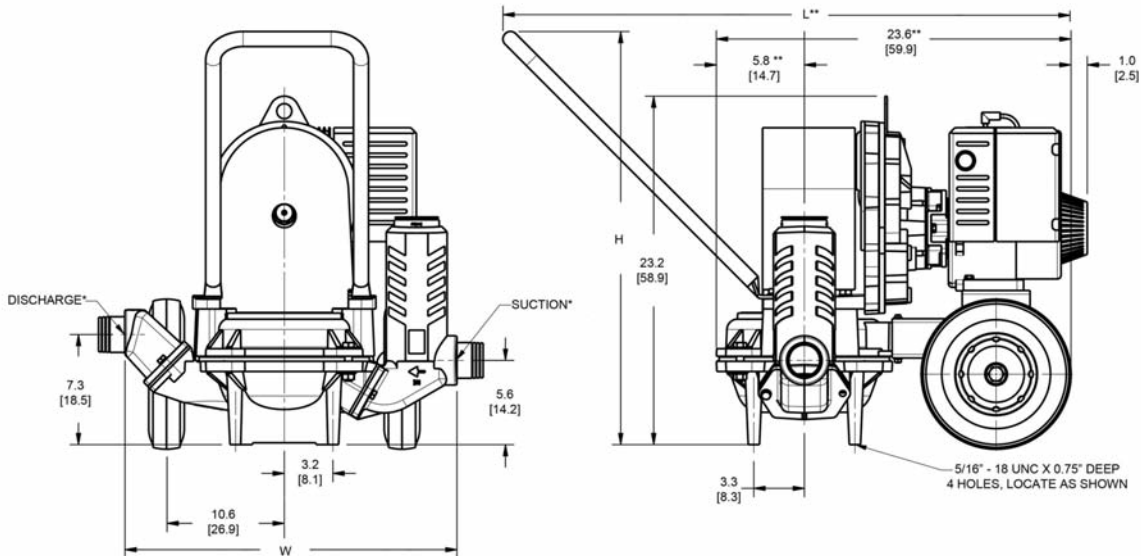

## Standard Features

- Driver Options: Gasoline, Diesel or Electric Single & Three Phase Motors
- 2" to 3" NPT Port Sizes
- Maximum Temperature 180° F
- Models 336E-96/335E-96—1.5 HP Single Phase, 115/230 VAC Volt Motor with Manual Reset Overload
- Models 336G-K6/335G-K6—Kit Furnished Less Engine. For use with Gasoline or Diesel Engines with 0.75" Keyed Shaft (SAE J609a Mounting Flange)
- Models 336E-K6/335E-K6—Kit Furnished Less Motor. For use with Electric Motor (1725 RPM) or Air Motor with a Minimum of 1.5 HP (56C Mounting Flange Required)