

Please read and save this Repair Parts Manual. Read this manual and the General Operating Instructions carefully before attempting to assemble, install, operate or maintain the product described. Protect yourself and others by observing all safety information. The Safety Instructions are contained in the General Operating Instructions. Failure to comply with the safety instructions accompanying this product could result in personal injury and/or property damage! Retain instructions for future reference.

Centrifugal Pumps

Cast Iron & Bronze Models

Refer to form 1808-634-00 for General Operating and Safety Instructions.

Description

These non self-priming centrifugal pumps are intended for liquid transfer, heating and cooling circulation, booster service and other industrial applications where no suction lift is required.

All models feature a semi-open clog-resistant impeller, and a ball bearing electric motor. A dual volute casing is used on all models except 4240. A mechanical seal (comprised of carbon, ceramic, Buna N elastomer, and stainless steel components) isolates motor shaft from liquid being pumped. Discharge port on pump casing can be rotated in 90° increments, with vent and drain plugs for all positions. Handles liquids from 40° to 180° F (4° to 82° C). Maximum ambient temperature 104° F (40° C). Casing working pressure to 100 psi (689 kPa). These are manual units, no controls are supplied. For use with nonflammable, non-abrasive liquids, compatible with pump component materials.

BRONZE UNITS

These pumps conform to the above standards, plus are well suited for salt water handling. They are sized to handle up to 1.03 specific gravity liquids. They also feature provisions for the installation of an automatic seal wash. This may extend shaft seal life by retarding salt crystallization on seal wear face. Seal wash hose is included.

FLANGED UNITS

These pumps accommodate flange type suction and discharge piping connections.

Specifications

Model	DRIVER		NEMA Frame	Power Supply		RPM	PUMP	WEIGHT	
	HP	Enclosure		@ 60 Hz	Suc. x Dis.		Cast Iron (lbs.)	Bronze (lbs.)	
3150	2	TEFC	145JM	230/460 VAC, 3-phase		3600	2"x1 1/2"NPT	69	76
3151	3	TEFC	182JM	230/460 VAC, 3-phase		3600	2"x1 1/2"NPT	83	90
3152	5	TEFC	184JM	230/460 VAC, 3-phase		3600	2"x1 1/2"NPT	100	107
3154	3	TEFC	182JM	230/460 VAC, 3-phase		3600	2"x1 1/2"FLG	91	—
3155	5	TEFC	184JM	230/460 VAC, 3-phase		3600	2"x1 1/2"FLG	108	—
3156	2	TEFC	56J	115/230 VAC, 1-phase		3450	2"x1 1/2"NPT	65	72
3157	2	TEFC	56J	230/460 VAC, 3-phase		3450	2"x1 1/2"NPT	64	71
3158	2	ODP	56J	115/230 VAC, 1-phase		3450	2"x1 1/2"NPT	62	69
3159	2	ODP	56J	230/460 VAC, 3-phase		3450	2"x1 1/2"NPT	61	68
315A	3	TEFC	56J	230 VAC, 1-phase		3450	2"x1 1/2"NPT	75	82
315B	3	TEFC	56J	230/460 VAC, 3-phase		3450	2"x1 1/2"NPT	74	81
315C	3	ODP	56J	230 VAC, 1-phase		3450	2"x1 1/2"NPT	72	79
315D	3	ODP	56J	230/460 VAC, 3-phase		3450	2"x1 1/2"NPT	71	78
315E	5	TEFC	184JM	230 VAC, 1-phase		3600	2"x1 1/2"NPT	121	128
4240	7 1/2	TEFC	184JM	230/460 VAC, 3-phase		3600	2"x1 1/2"NPT	108	115
4250	10	TEFC	184JM	230/460 VAC, 3-phase		3600	3"x2"NPT	120	127
4251	15	TEFC	215JM	230/460 VAC, 3-phase		3600	3"x2"NPT	195	204
4260	7 1/2	TEFC	184JM	230/460 VAC, 3-phase		3600	3"x3"NPT	117	125
4261	10	TEFC	184JM	230/460 VAC, 3-phase		3600	3"x3"NPT	124	131

(TEFC) Totally Enclosed Fan Cooled, (ODP) Open Drip Proof, (NPT) National Pipe Thread, (FLG) 125 lb. Flange

NOTE: Driver data is subject to change without notice, see label on driver for actual specifications.

Centrifugal Pumps

Cast Iron & Bronze Models

Performance Chart

Model	GPM of Water at Total Head in Feet											Max. Head†	
	10'	20'	30'	40'	50'	60'	70'	80'	90'	100'	110'		
315 (2HP)	170 gpm	150	130	100	65	25	–	–	–	–	–	–	62 ft.
NPSHR‡	23 ft.	20	18	15	14	14	*	*	*	*	*	*	
315 (3HP)	–	–	165	145	125	95	60	15	–	–	–	–	82
NPSHR‡	*	*	22	20	18	15	14	14	*	*	*	*	
315 (5HP)	–	–	–	–	200	185	165	145	120	90	50	–	115
NPSHR‡	*	*	*	*	25	25	23	20	17	15	14	–	
426 (7½HP)	–	–	–	425	385	340	285	200	75	–	–	–	94
NPSHR‡	*	*	*	23	19	15	12	10	7	*	*	*	
426 (10HP)	–	–	–	500	450	395	340	270	165	–	–	–	98
NPSHR‡	*	*	*	25	25	19	15	12	9	*	*	*	

Model	GPM of Water at Total Head in Feet											Max. Head†	
	80'	90'	100'	110'	120'	130'	140'	150'	160'	170'	180'		
424 (7½HP)	178 gpm	170	158	145	130	110	92	70	40	0	–	–	170 ft.
NPSHR‡	19 ft.	18	17	15	13	11	9	*	*	*	*	*	
425 (10HP)	333	300	280	250	210	170	100	–	–	–	–	–	145
NPSHR‡	16	14	12	10	7	4	*	*	*	*	*	*	
425 (15HP)	385	365	345	325	305	280	255	225	196	160	115	–	194
NPSHR‡	22	20	18	16	14	12	10	8	6	4	*	*	

(*) Operation of pumps beyond range indicated will result in reduced pump life, pump damage and/or motor damage.

(†) Shut-off; to convert psi, multiply by specific gravity and divide by 2.31.

(‡) NPSHR: Net Positive Suction Head Required by pump in feet of water at GPM indicated, under flooded suction conditions. Insufficient NPSH can cause pump cavitation, resulting in a noisy pump and reduced pump life.

Installation

1. Check Performance Chart for recommended NPSHR. Problems will arise in operation of this pump unless the recommended NPSHR is supplied to the pump (see "Troubleshooting").

2. BRONZE UNITS

Because of crystallization and erosive material on the shaft seal (Ref. Nos. 9, 10), we recommend installation of seal-wash hose (Ref. No. 21). Using a wrench, remove the pipe plug (Ref. No. 20) from adapter (Ref. No. 3) and pipe plug (Ref. No. 15) from casing (Ref. No. 14) (remove pipe plug on the 3 o'clock position). Install sealwash hose.

Maintenance

⚠ WARNING *Make certain that unit is disconnected from power source before attempting to service or remove any component.*

REMOVAL OF OLD SEAL

Refer to Figure 2.

IMPORTANT: Always replace both seal seat (Ref. No. 9) and seal head (Ref. No. 10) to insure proper mating of components! Also, impeller seal (Ref. No. 16) (where applicable) should be replaced anytime impeller fastener (Ref. No. 13) has been removed.

1. Remove fasteners (Ref. No. 6) that connect adapter (Ref. No. 3) to casing (Ref. No. 14).

2. Remove casing and o-ring (Ref. No. 8).

⚠ CAUTION *Care should be taken not to pinch or "shave" o-ring between adapter and casing.*

3. Using a wrench remove impeller fastener, impeller seal (where applicable), and impeller (Ref. No. 12).

IMPORTANT: Care should be taken to insure that the same number of shim washers (Ref. No. 11) are replaced behind impeller as were removed. These shim washers are located directly behind impeller. These washers as well as impeller key (Ref. No. 19) (where applicable) become loose as impeller is removed.

Models 3150 thru 315E and 4240 thru 4261

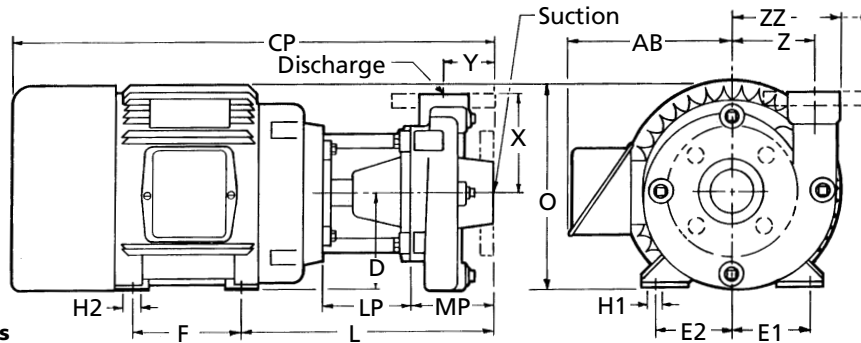

Figure 1 - Dimensions

Dimensions (Inches)

Model	SUC	DIS	AB†	CP†	D	E1	E2	F	H1
3150	2*	1½*	6⅞	17 ⁹ / ₁₆	3½	2¾	2¾	5	11 ¹ / ₃₂
3151	2*	1½*	7½	21 ⁵ / ₈	4½	3¾	3¾	4½	13 ³ / ₃₂
3152	2*	1½*	7½	21 ⁵ / ₈	4½	3¾	3¾	5½	13 ³ / ₃₂
3154	2**	1½**	7½	21 ⁵ / ₈	4½	3¾	3¾	4½	13 ³ / ₃₂
3155	2**	1½**	7½	21 ⁵ / ₈	4½	3¾	3¾	5½	13 ³ / ₃₂
3156	2*	1½*	4⅝	17 ³ / ₄	3½	2 ⁷ / ₁₆	2 ⁷ / ₁₆	3	7 ⁷ / ₈
3157	2*	1½*	4⅞	16 ⁵ / ₈	3½	2 ⁷ / ₁₆	2 ⁷ / ₁₆	3	7 ⁷ / ₈
3158	2*	1½*	—	17 ¹ / ₄	3½	2 ⁷ / ₁₆	2 ⁷ / ₁₆	3	7 ⁷ / ₈
3159	2*	1½*	—	16 ¹ / ₄	3½	2 ⁷ / ₁₆	2 ⁷ / ₁₆	3	7 ⁷ / ₈
315A	2*	1½*	4⅞	18 ⁵ / ₈	3½	2 ⁷ / ₁₆	2 ⁷ / ₁₆	3	7 ⁷ / ₈
315B	2*	1½*	4⅞	18 ⁵ / ₈	3½	2 ⁷ / ₁₆	2 ⁷ / ₁₆	3	7 ⁷ / ₈
315C	2*	1½*	—	17 ³ / ₈	3½	2 ⁷ / ₁₆	2 ⁷ / ₁₆	3	7 ⁷ / ₈
315D	2*	1½*	—	17 ¹ / ₄	3½	2 ⁷ / ₁₆	2 ⁷ / ₁₆	3	7 ⁷ / ₈
315E	2*	1½*	8 ⁵ / ₈	24 ⁵ / ₃₂	4½	3¾	3¾	5½	13 ³ / ₃₂
4240	2*	1½*	7½	21 ³ / ₈	4½	3¾	3¾	5½	13 ³ / ₃₂
4250	3*	2*	7½	21 ¹⁷ / ₃₂	4½	3¾	3¾	5½	13 ³ / ₃₂
4251	3*	2*	8¼	26 ¹ / ₃₂	5¼	4¼	4¼	7	7 ¹ / ₁₆
4260	3*	3*	7½	22 ³ / ₈	4½	3¾	3¾	5½	13 ³ / ₃₂
4261	3*	3*	7½	22 ³ / ₈	4½	3¾	3¾	5½	13 ³ / ₃₂

Model	H2	L	LP	MP	O†	X	Y	Z	ZZ
3150	11 ¹ / ₃₂	10 ³ / ₈	4⅞	4	7 ⁷ / ₈	4¾	2½	4	5¼
3151	13 ³ / ₃₂	12 ¹¹ / ₁₆	4⅞	4	9 ⁹ / ₃₂	4¾	2½	4	5¼
3152	13 ³ / ₃₂	11 ³ / ₄	4⅞	4	9 ⁹ / ₃₂	4¾	2½	4	5¼
3154	13 ³ / ₃₂	12 ¹¹ / ₁₆	4⅞	4	9 ⁹ / ₃₂	4¾	2½	4	6½
3155	13 ³ / ₃₂	11 ³ / ₄	4⅞	4	9 ⁹ / ₃₂	4¾	2½	4	6½
3156	11 ¹ / ₃₂	8 ¹⁹ / ₃₂	2 ¹ / ₃₂	4	8 ¹¹ / ₁₆	4¾	2½	4	5¼
3157	11 ¹ / ₃₂	8 ¹⁹ / ₃₂	2 ¹ / ₃₂	4	8 ¹¹ / ₁₆	4¾	2½	4	5¼
3158	11 ¹ / ₃₂	8 ¹⁹ / ₃₂	2 ¹ / ₃₂	4	8 ¹¹ / ₁₆	4¾	2½	4	5¼
3159	11 ¹ / ₃₂	8 ¹⁹ / ₃₂	2 ¹ / ₃₂	4	8 ¹¹ / ₁₆	4¾	2½	4	5¼
315A	11 ¹ / ₃₂	8 ¹⁹ / ₃₂	2 ¹ / ₃₂	4	8 ²⁵ / ₃₂	4¾	2½	4	5¼
315B	11 ¹ / ₃₂	8 ¹⁹ / ₃₂	2 ¹ / ₃₂	4	8 ¹¹ / ₁₆	4¾	2½	4	5¼
315C	11 ¹ / ₃₂	8 ¹⁹ / ₃₂	2 ¹ / ₃₂	4	8 ¹¹ / ₁₆	4¾	2½	4	5¼
315D	11 ¹ / ₃₂	8 ¹⁹ / ₃₂	2 ¹ / ₃₂	4	8 ¹¹ / ₁₆	4¾	2½	4	5¼
315E	13 ³ / ₃₂	11 ³ / ₄	4⅞	4	9 ⁹ / ₃₂	4¾	2½	4	5¼
4240	13 ³ / ₃₂	11 ½	3½	4 ³ / ₈	9 ⁹ / ₃₂	5 ⁷ / ₈	2 ⁷ / ₁₆	3 ²⁷ / ₃₂	5 ¹ / ₁₆
4250	13 ³ / ₃₂	11 ²¹ / ₃₂	3½	4 ¹⁷ / ₃₂	9 ⁹ / ₃₂	5	2 ²⁵ / ₃₂	4 ³ / ₄	6 ⁵ / ₁₆
4251	7 ¹ / ₁₆	12 ¹⁷ / ₃₂	3½	4 ¹⁷ / ₃₂	10 ⁷ / ₈	5	2 ²⁵ / ₃₂	4 ³ / ₄	6 ⁵ / ₁₆
4260	13 ³ / ₃₂	12½	4⅞	4 ³ / ₄	9 ⁹ / ₃₂	6½	2¾	4½	6¾
4261	13 ³ / ₃₂	12½	4⅞	4¾	9 ⁹ / ₃₂	6½	2¾	4½	6¾

NOTE: All dimensions have a tolerance of ±1/8".

(*) Standard NPT (Female) Pipe Thread. (**) Standard 125 lb. Pipe Flange.

(†) This dimension may vary due to motor manufacturer's specifications.

For Repair Parts, contact dealer where pump was purchased.

Please provide following information:

- Model number
- Serial number (if any)
- Part description and number as shown in parts list

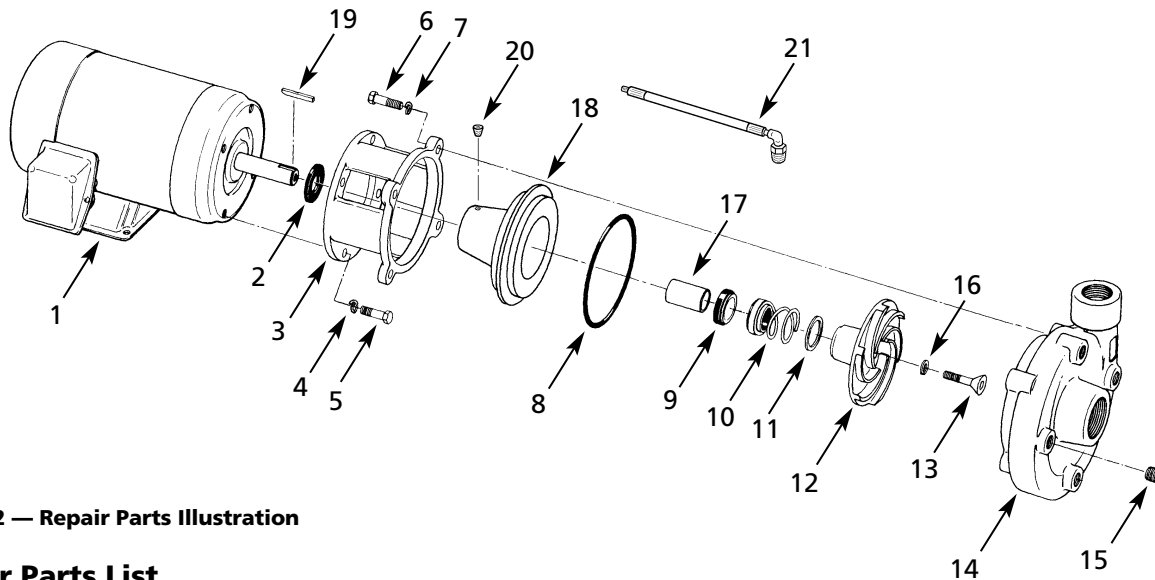

Figure 2 — Repair Parts Illustration

Repair Parts List

Ref. No.	Description	Part Number For Models:					Qty.
		3150 2HP (145JM)	3158 3159 3156 3157 2HP (56J)	3151 (NPT) 3154 (FLG) 3HP (182JM)	315C 315D 315A 315B 3HP (56J)	315E (NPT) 3152 (NPT) 3155 (FLG) 5HP (184JM)	
1	Motor -1 Phase ODP -3 Phase ODP -1 Phase TEFC -3 Phase TEFC	—	◆ 1626-024-00 ◆ 1626-025-00 ◆ 1626-070-00 ◆ 1626-054-00	—	◆ 1626-026-00 ◆ 1626-027-00 ◆ 1626-071-00 ◆ 1626-072-00	— — 1626-078-00 1626-044-00	1
2	Slinger washer	1470-093-00	1534-000-00	1470-093-00	1534-000-00	1470-093-00	1
3	Adapter -Cast Iron -Bronze	1470-001-02 1470-004-09	4890-030-01 4890-032-01	1470-001-02 1470-004-09	4890-030-01 4890-032-01	1470-001-02 1470-004-09	1
4	Washer	*	*	*	*	*	4
5	Fastener	*	*	*	*	*	4
6	Fastener	*	*	*	*	*	4
7	Washer	*	*	*	*	*	4
8	O-ring -Buna N	*	*	*	*	*	1
9,10	† Shaft seal assembly -Buna-N	1640-163-90	1640-161-96	1640-163-90	1640-161-96	1640-163-90	1
11	Impeller shim set includes (1) 0.030", (1) 0.020", (1) 0.010"	1664-000-90	1806-044-90	1664-000-90	1806-044-90	1664-000-90	1
12	Impeller	3150-014-09	3156-010-01	3151-014-09	3156-010-02	1471-003-09	1
13	Impeller fastener	1757-010-00	1784-001-00	1757-010-00	1784-001-00	1757-010-00	1
14	Casing -Cast Iron (NPT) -Cast Iron (Flanged) -Bronze (NPT)	1470-000-01 — 1470-005-09	1470-000-01 — 1470-005-09	1470-000-01 1469-000-01 1470-005-09	1470-000-01 — 1470-005-09	1470-000-01 1469-000-01 1470-005-09	1
15	Pipe plug	*	*	*	*	*	4
16	O-ring -Buna N	*	—	*	—	*	1
17	Shaft sleeve	1472-000-00	—	1472-000-00	—	1472-000-00	1
18	Casing cover	—	—	—	—	—	—
19	Impeller key	1471-030-00	—	1471-030-00	—	1471-030-00	1
20	Pipe plug	*	*	*	*	*	1
21	Hose	4261-170-00	4261-170-00	4261-170-00	4261-170-00	4261-170-00	1
Δ ‡	Seal Kit -Buna N (standard)	3150-300-94	3156-300-94	3150-300-94	3156-300-94	3150-300-94	1
Δ ‡	Seal Kit -Buna N & sil. carb. (optional)	3150-300-93	3156-300-93	3150-300-93	3156-300-93	3150-300-93	1
Δ ‡	Seal Kit -Viton (optional)	3150-300-91	3156-300-91	3150-300-91	3156-300-91	3150-300-91	1
Δ ‡	Seal Kit -Viton & sil. carb. (optional)	3150-300-92	3156-300-92	3150-300-92	3156-300-92	3150-300-92	1

(Δ) Not shown; (*) Standard hardware item, available locally; (†) Includes all required seals Ref. Nos. 8, 9, 10, 16; (‡) Seal head and seat available as set only; (◆) Requires foot 1626-040-90. When replacing a shaft seal assembly, a new impeller seal (Ref. No. 16) should also be used (where applicable).

For Repair Parts, contact dealer where pump was purchased.

Please provide following information:

- Model number
- Serial number (if any)
- Part description and number as shown in parts list

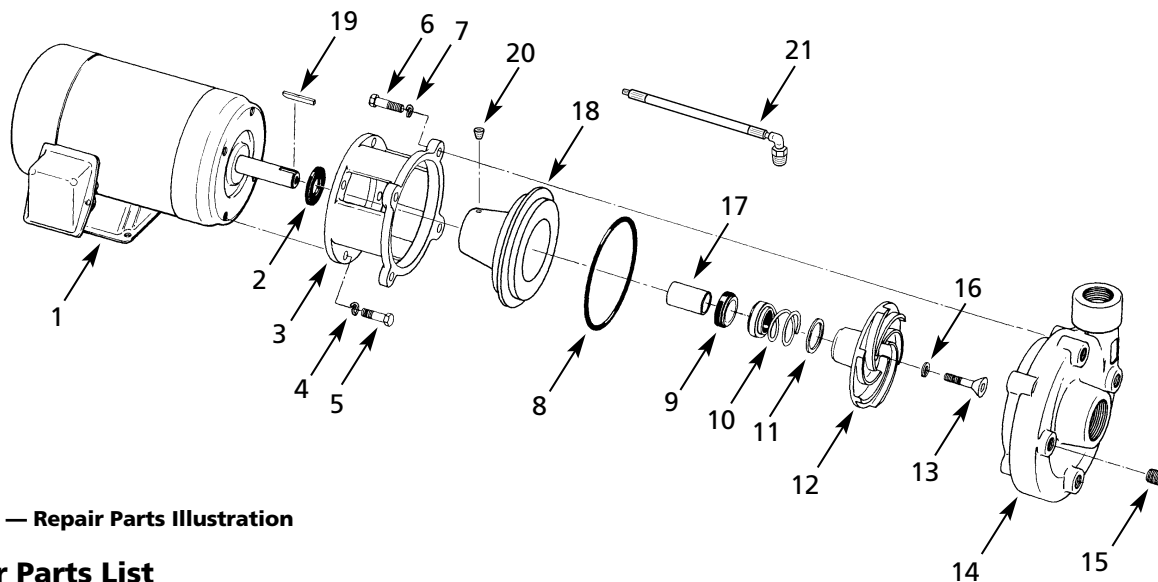

Figure 3 — Repair Parts Illustration

Repair Parts List

Ref. No.	Description	Part Number For Models:					Qty.
		4260 7 1/2 HP (184JM)	4261 10HP (184JM)	4240 7 1/2 HP (184JM)	4250 10HP (184JM)	4251 15 HP (215JM)	
1	Motor	1626-045-00	1626-046-00	1626-045-00	1626-046-00	1626-047-00	1
2	Slinger washer	1470-093-00	1470-093-00	1470-093-00	1470-093-00	1470-093-00	1
3	Adapter -Cast Iron -Bronze	1470-001-02 1470-004-09	1470-001-02 1470-004-09	4240-030-09 4252-033-01	4240-030-09 4252-033-01	4250-030-09 4252-033-01	1
4	Washer	*	*	*	*	*	4
5	Fastener	*	*	*	*	*	4
6	Fastener	*	*	*	*	*	4
7	Washer	*	*	*	*	*	4
8	O-ring -Buna-N	*	*	*	*	*	1
9, 10	† Shaft seal assembly -Buna-N	1640-163-90	1640-163-90	1640-163-90	1640-163-90	1640-163-90	1
11	Impeller shim set includes (1) 0.030", (1) 0.020", (1) 0.010"	1664-000-90	1664-000-90	1664-000-90	1664-000-90	1664-000-90	1
12	Impeller	4260-014-01	2217-009-09	4240-014-01	4250-014-01	4250-014-01	1
13	Impeller fastener	1760-010-00	1760-010-00	1757-010-00	1757-010-00	1756-000-00	1
14	Casing -Cast Iron -Bronze	2217-001-01 2217-002-09	2217-001-01 2217-002-09	4240-001-09 4240-004-01	4250-001-09 4250-004-01	4250-001-09 4250-004-01	1
15	Pipe plug	*	*	*	*	*	4
16	O-ring -Buna N	*	*	*	*	*	1
17	Shaft sleeve	1472-000-00	1472-000-00	1472-000-00	1472-000-00	1472-000-00	1
18	Casing cover -Cast Iron -Bronze	— —	— —	— 4240-024-01	— 4240-024-01	— 4240-024-01	1
19	Impeller key	1471-030-00	1471-030-00	1471-030-00	1471-030-00	1471-030-00	1
20	Pipe plug	*	*	*	*	*	1
21	Hose	4261-170-00	4261-170-00	4261-170-00	4261-170-00	4261-170-00	1
Δ ‡	Seal Kit -Buna N (standard)	3150-300-94	3150-300-94	4240-300-94	4240-300-94	4240-300-94	1
Δ ‡	Seal Kit -Buna N & sil. carb. (optional)	3150-300-93	3150-300-93	4240-300-93	4240-300-93	4240-300-93	1
Δ ‡	Seal Kit -Viton (optional)	3150-300-91	3150-300-91	4240-300-91	4240-300-91	4240-300-91	1
Δ ‡	Seal Kit -Viton & sil. carb. (optional)	3150-300-92	3150-300-92	4240-300-92	4240-300-92	4240-300-92	1

(Δ) Not shown; (*) Standard hardware item, available locally; (‡) Includes all required seals Ref. Nos. 8, 9, 10, 16; (†) Seal head and seat available as set only. When replacing a shaft seal assembly, a new impeller seal (Ref. No. 16) should also be used.

Centrifugal Pumps

Cast Iron & Bronze Models

Maintenance (Continued)

4. Seal head and shaft sleeve (Ref. No. 17) (where applicable) can now be pulled from shaft.
5. Pry seal seat from adapter.
6. Push seal head from shaft sleeve (where applicable).

INSTALLATION OF NEW SEAL

▲ CAUTION *The precision lapped faces on shaft seal are easily damaged. Handle your replacement seal carefully.*

1. Thoroughly clean all surfaces of seal seat cavity.
2. Using a clean cloth, wipe shaft and shaft sleeve (where applicable) and make certain that they are perfectly clean.
3. Wet rubber portion of new seal seat with a light coating of soapy water. While wearing clean gloves or using a clean light rag, press seal seat squarely into adapter recess. Avoid scratching white ceramic surface. If seat will not position properly, place a cardboard washer over polished surface and use a piece of pipe to press in, firmly but gently.
4. Dispose of cardboard washer. Check again to see that polished surface is free of dirt and all other foreign

particles and that it has not been scratched or damaged.

5. Wet inside rubber portion of new seal head with a light coating of soapy water. Slide head onto shaft/shaft sleeve. Slide shaft sleeve with seal head onto motor shaft (where applicable). Seal head and seal seat will meet. Reinstall any shims which have been removed. (See "Shim Adjustment" section.)
6. Replace impeller key (where applicable), and impeller. Replace impeller seal (where applicable) before screwing impeller fastener in place.
7. Reassemble pump.
8. A short "run-in" period may be necessary to provide completely leak free seal operation.

SHIM ADJUSTMENT

When installing a replacement impeller (Ref. No. 12) or motor (Ref. No. 1), it may be necessary to adjust the number of shims (Ref. No. 11) to insure proper running clearance between impeller and casing (Ref. No. 14). Proceed as follows:

NOTE: A proper running clearance is less than 0.010".

1. For impeller replacement, add one 0.010" shim in addition to those removed originally.
 2. For motor replacement, add two 0.010" shims in addition to shims removed during disassembly.
 3. Reassemble pump as described in Steps 6 and 7. (See "Installation of New Seal" section.)
- IMPORTANT:** Insure that casing is snugly in place and check shaft to make sure it is turning freely (rotate impeller by impeller fastener, Ref. No. 13, with a wrench). If it turns freely, check to insure that adapter (Ref. No. 3) and casing are fitted "metal to metal" where they meet on outside. If they are not "metal to metal", tighten fasteners (Ref. No. 6) and recheck shaft for free turning. Tighten carefully, turning shaft while tightening so that motor bearings are not damaged in the event that too many shims were installed. If shaft seizes before fasteners are completely tight, disassemble pump and remove one shim and repeat reassembly.

