

1"-2" Self-Priming Chemical Pumps



Model
1SP07C-3P

Model
2SP30C-3P

- **Cast Iron Construction with EPDM/EPR Seals**
- **Easy Cleanout Pull From Rear Design**
- **1" to 2" NPT Port Sizes**
- **Maximum Temperature 180° F**
- **Maximum Flow 130 GPM**
- **Maximum Head 100 Ft. (43 PSI)**
- **Self-Priming up to 20 Feet with Built-in Check Valve**
- **Self-Cleaning, Clog Resistant Impeller**
- **1/2 to 3 HP 56J Dual Cycle 50/60 Hz Single or Three Phase TEFC Motors**
- **Motors Feature 303 Stainless Steel Shaft**

This line of AMT Self-Priming Centrifugal pumps is designed for industrial and commercial applications requiring high volume liquid transfer, waste water drainage and chemical processing. These pumps feature a self-cleaning clog resistant impeller capable of handling up to 3/8" diameter semi-solid and EPDM/EPR seals for liquid chemical transfer with specific gravities up to 1.3. (Verify chemical capability with liquids) Built-in check valve enables consistent self-priming to 20 feet. Dual volute design reduces radial load on motor. Pumps feature Dual cycle 50/60 Hz TEFC motors.

Performance of Self-Priming Centrifugal Pumps

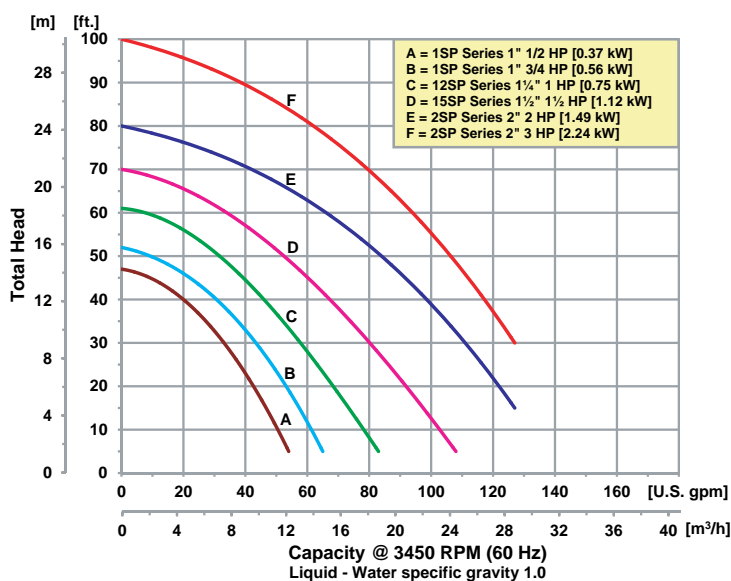

400 Spring Street • Royersford, PA 19468 USA

www.amtpump.com • 888-amt-pump (268-7867)

For use with nonflammable liquids compatible with pump component materials. Viton® and Teflon® are registered trademarks of E. I. DuPont.

Pump Dimensional & Specification Data

Model	Curve	HP	PH	ENC	Voltage @ 60 Hz +	Full Load Amps	SUC*	DIS*	L**	W**	H	Ship Wt. (Lbs.)	Maximum Solids Handling Capacity
1SP05C-1P	A	1/2	1	TEFC	115-208/230	9/5	1	1	18.0 [45.7]	9.3 [23.6]	9.3 [23.6]	55	1/4"
1SP05C-3P			3	TEFC	208-230/460	3/2	1	1	17.3 [43.9]	9.3 [23.6]	9.3 [23.6]	52	
1SP07C-1P	B	3/4	1	TEFC	115-208/230	9/5	1	1	18.5 [47.0]	9.3 [23.6]	9.3 [23.6]	60	
1SP07C-3P			3	TEFC	208-230/460	3/2	1	1	18.0 [45.7]	9.3 [23.6]	9.3 [23.6]	53	
12SP10C-1P	C	1	1	TEFC	115-208/230	12/6	1 1/4	1 1/4	18.8 [47.7]	9.3 [23.6]	9.3 [23.6]	61	3/8"
12SP10C-3P			3	TEFC	208-230/460	4/2	1 1/4	1 1/4	17.3 [43.9]	9.3 [23.6]	9.3 [23.6]	57	
15SP15C-1P	D	1 1/2	1	TEFC	115-208/230	22/11	1 1/2	1 1/2	20.5 [52.0]	11.0 [27.9]	11.0 [28.0]	83	1/2"
15SP15C-3P			3	TEFC	208-230/460	6/3	1 1/2	1 1/2	20.3 [51.5]	11.0 [27.9]	11.0 [28.0]	73	
2SP20C-1P	E	2	1	TEFC	115-208/230	28/14	2	2	21.3 [54.1]	11.0 [27.9]	11.0 [28.0]	85	
2SP20C-3P			3	TEFC	208-230/460	7/4	2	2	20.8 [52.8]	11.0 [27.9]	11.0 [28.0]	78	
2SP30C-1P	F	3	1	TEFC	115-208/230	16	2	2	21.8 [55.4]	11.0 [27.9]	11.0 [28.0]	94	
2SP30C-3P			3	TEFC	208-230/460	8/4	2	2	21.3 [54.1]	11.0 [27.9]	11.0 [28.0]	82	

(*) Standard NPT (Female) pipe thread.

(**) This dimension may vary due to motor manufacturer's specifications.

(+) 3-Phase motors can also operate on 50 Hz. (This will change full load amps, service factor and RPM)

NOTE: Dimensions are in inches (centimeters) and have a tolerance of $\pm 1/4$ ".

NOTE: Electric supply for ALL motors must be within $\pm 10\%$ of nameplate voltage rating (e.g. 230V $\pm 10\%$ = 207 to 253).

Do Not Use With Petroleum Based Liquids!

Standard Features

- Cast Iron Construction with EPDM/EPR Mechanical Seals
- Built-in Check Valve for Fast Priming
- NEMA 56J Motors with Stainless Steel Shafts
- Maximum Working Pressure 125 PSI
- Available in Dual 50/60 Hz TEFC, Single or Three Phase Motors
- Self-priming to 20 Ft.
- Self-cleaning, Clog Resistant Impellers
- **Designed to handle liquids of specific gravities up to 1.3**
- **Do Not Use With Petroleum Based Liquids!**
- QSP—Quick Ship for Many Models

Hazardous Duty/Explosion Proof motors available from stock ranging from 1 to 10 HP; CALL FOR QUOTATION & LEAD TIME!

1", 1-1/4" NPT Pumps

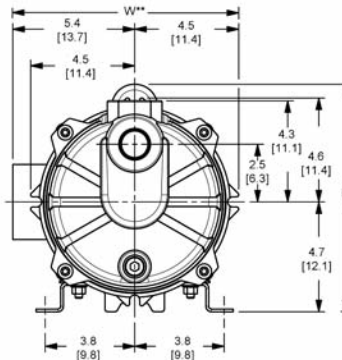
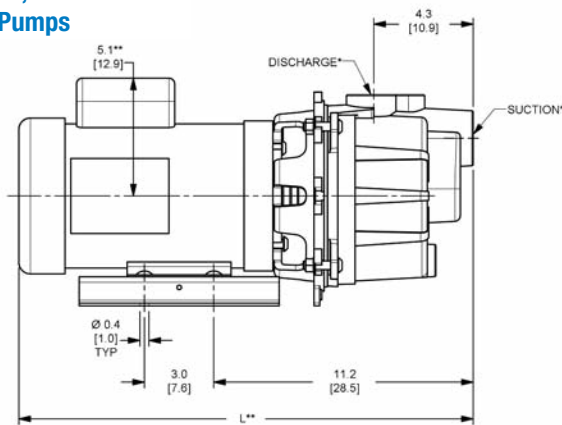

1-1/2", 2" NPT Pumps

