



Engine Driven Portable High Pressure Pumps

Die-Cast Aluminum or Cast Iron Self-Priming Engine Driven Pumps with B&S or Honda Gasoline or Yanmar Diesel Engines. Provides Home Fire Protection with Optional Hose Kit

- **Horsepower 4.7 to 6.5**
- **2" Suction and Discharge Port Sizes**
- **Die-Cast Aluminum or Cast Iron**
- **Max. Flow: 120 GPM**
- **Max. Head: 88 PSI**
- **Max. Lift: 18 ft.**
- **Silicon Carbide Seal**
- **Use for Fire Protection or Irrigation**
- **Optional High Pressure Hose Kit**
- **Optional Viton® Elastomers**
- **Optional Wheel Kit**



High Pressure Hose Kit 55-338

These Pumps are capable of developing 75 lbs. of pressure at 30 GPM. Use for fire protection or irrigation. Available with a wide choice of standard and heavy-duty gasoline and diesel fueled engines. Unit is standard with die-cast aluminum housing and impeller or Cast-Iron, G-Ruff Coat Teflon® housing with bronze impeller. All models standard with EPDM elastomers, Viton® fitted silicon-carbide self-lubricated seal. Many models are readily available "Off-the Shelf" for fast 24 hour shipment. For use with non-flammable liquids which are compatible with pump component materials.

*Viton® and Teflon® are registered trademarks of DuPont

COMMERCIAL DUTY

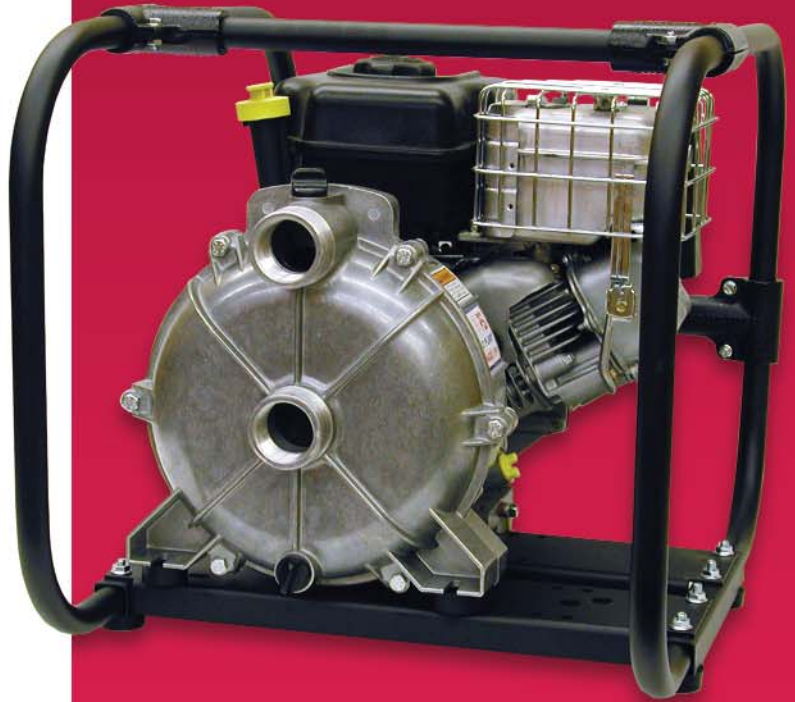

Model 2P5IR

Performance of High Pressure Pumps

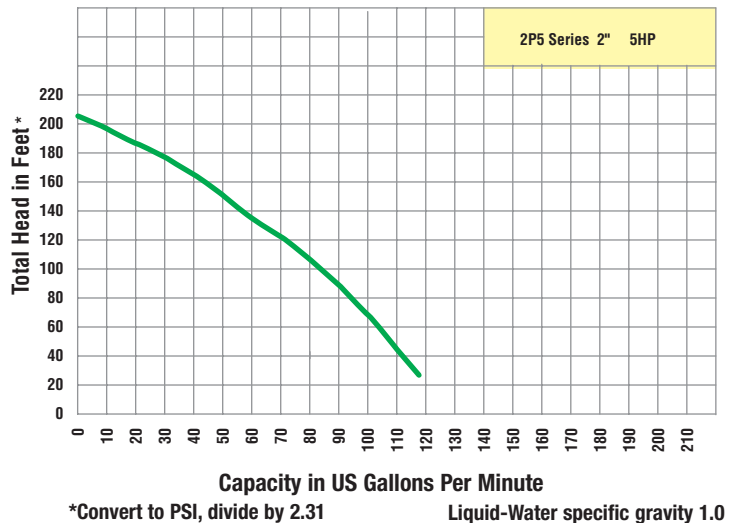

Portable High Pressure Pumps

2" General Purpose-High Pressure Pumps

Alum. Model #	Alum. Ship Wt. (lbs.)	Cast Iron Model #	Cast Iron Ship Wt. (lbs.)	Driver Type & HP	Seal Type & Elastomer/Faces	Tank Size (Qts.)	Run Time	Mounting
2P5A	64	N/A	N/A	B&S 5.5 HP OHV	Viton®*/Sic/Sic	3	1.4	Handle
2P5IR	86	2P5ICR	108	B&S 6.5 HP Pro	Viton®*/Sic/Sic	4	2	Roll Cage
2P5HR	82	2P5HCR	104	Honda 5.5 HP	Viton®*/Sic/Sic	3.88	2	Roll Cage
2P5YR	103	2P5YCR	125	Yanmar 4.7 HP	Viton®*/Sic/Sic	2.6	1.8	Roll Cage

5/8 Threaded Kit (Single)

Alum. Model #	Alum. Ship Wt. (lbs.)	Cast Iron Model #	Cast Iron Ship Wt. (lbs.)	Seal Type & Elastomer /Faces	Mounting
2P5	31	2P5C	31	Viton®*/Sic/Sic	Handle

2" High Pressure Hose Kit

Model #	Ship Wt. (lbs.)
55-338 (100 ft.)	38

*Viton® and Teflon® are registered trademarks of DuPont

Standard Features

- > Aluminum Closed Impeller and Cast Iron Volutes- Die Cast Aluminum Pump
- > Bronze Closed Impeller and Cast Iron Volute-Cast Iron Pump with G-Ruff Coat Teflon®.
- > Large Pump Casing
- > Built-In Check Valve
- > Horizontal Discharge and Male Threaded Connections
- > Silicon Carbide, Self-Lubricated Seal with Graphite Impregnated Seat and Viton® Elastomers
- > Choice of Briggs & Stratton, Honda gasoline or Yanmar Diesel Engines
- > Optional Wheel Kit
- > Strainer Supplied
- > Rubber Foot Mounting

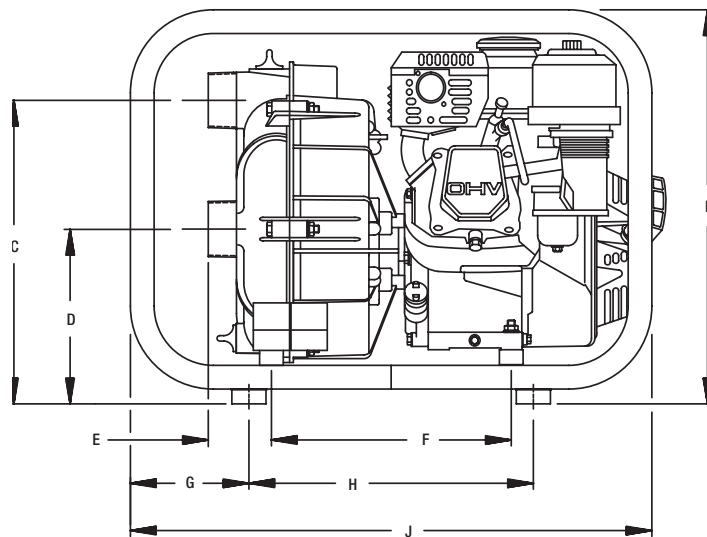
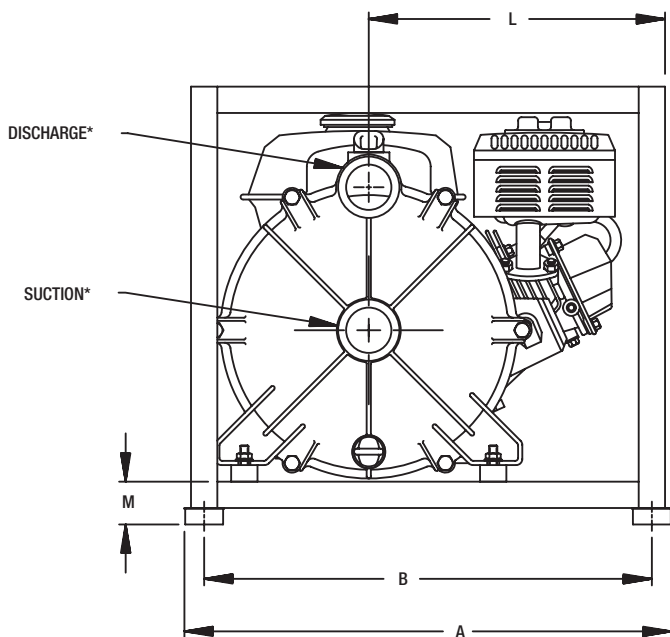

WARNING: Do not use in explosive atmosphere or for pumping volatile flammable liquids.
Viton® Elastomers including O-rings and check valve.

DIMENSIONS:
INCHES
[MILLIMETERS]

MODEL	A	B	C	D	E	F	G	H	J	K	L	M	DISCH*	SUCT*
2P5	19.50 [495]	17.00 [431.8]	12.81 [325.4]	7.38 [187.4]	2.83 [71.9]	10.29 [261.4]	5.00 [127.0]	15.00 [381.0]	24.3 [617]	20 [508]	11.36 [288.5]	1.62 [41.1]	* 2.00	* 2.00

(*) STANDARD NPT (MALE) PIPE THREAD.

HIGH PRESSURE PUMP



See price book page 8

The Gorman-Rupp Company reserves the right to discontinue any model or change specifications at any time without incurring any obligation.

CP23-24 / 0904