

Engine Driven Two Stage High Pressure/Fire Pumps

Model 2MP5AR



Close Up View of Optional 1-1/2" MNPT 2MPX-90 Flange Kit

- **Cast Aluminum Construction with Cast Iron Diffusers**
- **High Efficiency Two-Stage Precision Cast Aluminum Impellers**
- **2" NPTM Cast Iron Suction Port**
- **Three-Way Cast Iron Discharge Port**
- **Viton® Mechanical Seal with Silicon Carbide and Carbon Faces**
- **EPDM/EPR O-Rings and Gaskets**
- **Maximum Head up to 155 PSI**
- **Maximum Flow up to 160 GPM**
- **Built-in Flapper/Check Valve Permits Self-priming to 20 Ft.**
- **Heavy Duty Steel Roll Frame Included**
- **Engine Options: Honda, Briggs & Stratton Gasoline or Yanmar Diesel**
- **Optional Wheel Kit Available**

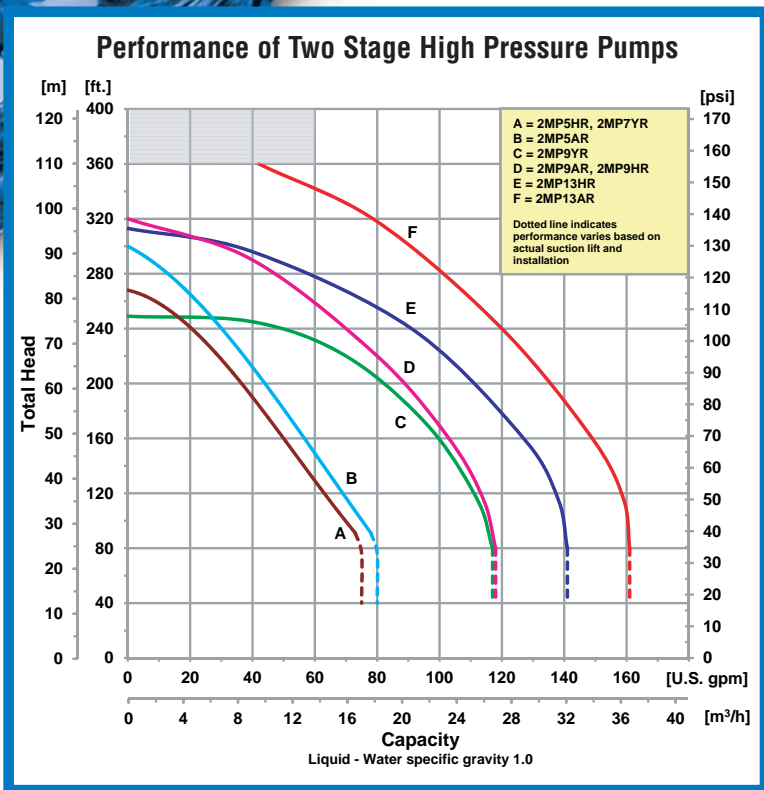

The IPT Self-priming Two-stage High Pressure Engine Driven pump includes precision cast high efficiency impellers to maximize performance and pressure. Cast iron diffusers for durability and extended life. Aluminum construction and heavy duty powder coated steel frame allows portability for use in many applications. This pump features cast iron male NPT ports, silicon carbide mechanical seals, EPDM/EPR O-rings and gaskets, built-in flapper/check valve and wrench for easy service of the pump. This unit is ideal for fire protection, emergency fire fighting, washdown and AG/sprinkler applications.



Engine Driven Two Stage High Pressure Pumps

Pump Dimensional & Specification Data

Model	Curve	Driver	Seal Type & Elastomer/Faces	Run Time (Hr.)	Tank Size (Gal/Ltr)	Ship Wt. (Lbs.)
2MP5HR	A	Honda GX160▲	Viton® Silicon Carbide/Carbon & EPDM/EPR O-rings, Gasket & Flapper/Check Valve	2.0	0.82/3.1	90
2MP7YR	A	Yanmar L70▲++		2.4	0.87/3.2	130
2MP5AR	B	B & S Vanguard▲		1.3	0.87/3.3	90
2MP9HR	C	Honda GX270▲		2.5	1.40/5.3	145
2MP9YR	C	Yanmar L100▲++		2.7	0.37/1.4	180
2MP9AR	D	B & S Vanguard▲		1.5	0.95/3.6	145
2MP13HR	E	Honda GX390▲++		2.5	1.60/6.1	185
2MP13AR	F	B & S Vanguard▲++		1.8	2.25/8.5	185

Construction: Aluminum

▲ Oil Alert Included

++ Electric Start

Model 2MP5 Series:

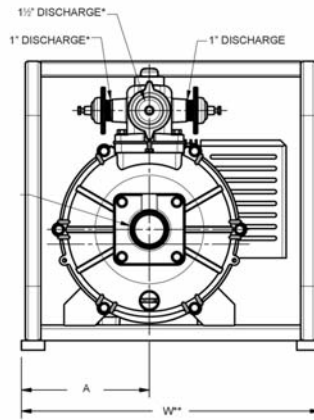
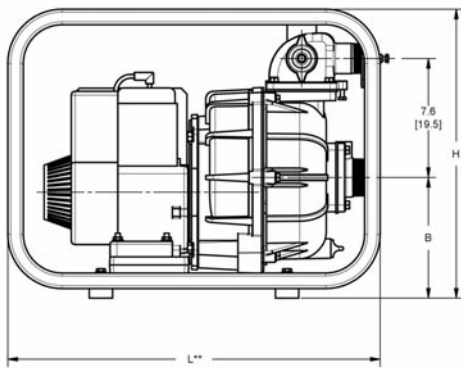

Model 2MP7/9/13 Series:

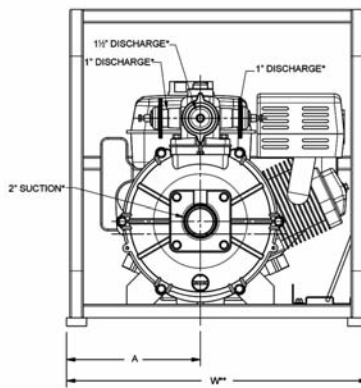
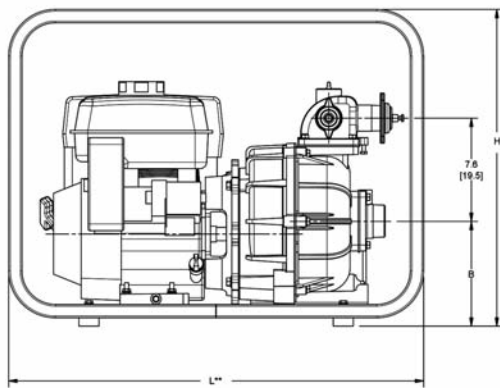

Standard Features

- Cast Aluminum Construction with Cast Iron Diffusers
- High Efficiency Two-Stage Precision Cast Aluminum Impellers
- 2" NPTM Cast Iron Suction Port
- **2MPX-90** - Optional 1-1/2" Suction Port Flange Kit Available
- Three-Way Cast Iron Discharge Port – includes (1) 1-1/2" NPTM & (2) 1" NPTM
- Viton® Mechanical Seal with Silicon Carbide/Carbon Faces
- EPDM/EPR O-rings & Gaskets
- Choice of Briggs & Stratton, Honda Gasoline or Yanmar Diesel Engines
- Heavy Duty Steel Roll Frame Included
- Maximum Head up to 155 PSI
- Maximum Temperature 200° F
- Maximum Flow up to 160 GPM
- Optional High Pressure Hose or Wheel Kit Available, See Accessories Pages for More Information
- **Models 2MP9/2MP13 meet or exceeds US Coast Guard Fire Pump Performance Requirement** as specified by 46 CFR 27.301 (Jan 1, 2004 Revision)

Model	HP Class ♦	SUC*	DIS*	A	B	L**	W**	H
2MP5HR	5 HP	2	3-Way	8.2 [21.0]	7.7 [19.7]	24.0 [60.9]	19.2 [48.7]	18.6 [47.2]
2MP7YR	7 HP	2	3-Way	8.2 [21.0]	11.6 [29.4]	24.0 [60.9]	19.2 [48.7]	18.6 [47.2]
2MP5AR	5 HP	2	3-Way	8.2 [21.0]	7.7 [19.7]	24.0 [60.9]	19.2 [48.7]	18.6 [47.2]
2MP9HR	9 HP	2	3-Way	7.8 [19.9]	10.0 [25.4]	31.0 [78.7]	22.5 [57.1]	23.6 [60.0]
2MP9YR	9 HP	2	3-Way	8.6 [22.0]	11.4 [29.2]	31.0 [78.7]	22.5 [57.1]	23.6 [60.0]
2MP9AR	9 HP	2	3-Way	7.8 [19.9]	10.0 [25.4]	31.0 [78.7]	22.5 [57.1]	23.6 [60.0]
2MP13HR	13 HP	2	3-Way	7.8 [19.9]	10.0 [25.4]	31.0 [78.7]	22.5 [57.1]	23.6 [60.0]
2MP13AR	13 HP	2	3-Way	7.8 [19.9]	10.0 [25.4]	31.0 [78.7]	22.5 [57.1]	23.6 [60.0]

(♦) HP Class represents market category and is not intended to define actual horsepower.

(*) Standard NPT (Male) pipe thread.

(**) This dimension may vary due to engine manufacturer's specifications.

NOTE: Dimensions are in inches (centimeters) and have a tolerance of ± 1/8".



A Gorman-Rupp Company

Manufacturer of AMT & IPT Pumps

400 Spring Street • Royersford, PA 19468 USA

www.amtpump.com • 888-amt-pump (268-7867)

The Gorman-Rupp Company reserves the right to discontinue any model or change specifications at any time without incurring any obligation.
©2012 American Machine and Tool Company. All rights reserved.



GORMAN-RUPP®

1212