

Please read and save this Repair Parts Manual. Read this manual and the General Operating Instructions carefully before attempting to assemble, install, operate or maintain the product described. Protect yourself and others by observing all safety information. The Safety Instructions are contained in the General Operating Instructions. Failure to comply with the safety instructions accompanying this product could result in personal injury and/or property damage! Retain instructions for future reference.

2-Inch Dewatering Pump

Refer to form 1808-633-00 for General Operating and Safety Instructions.

Description

This centrifugal pump includes a precision mechanical seal with stainless steel spring, Buna N seals, carbon face and ceramic seat, and a built-in check valve for better self-priming capabilities (up to 20 ft. suction lift). Handle liquids from 40° to 180° F (4° to 82° C). For use with nonflammable, non-abrasive liquids compatible with pump component materials.

Specifications

Suction inlet2" †
Discharge outlet2" †
(†) Standard NPT (female) pipe thread.	
Dimensions (overall)	. . .18.5 H x 16 W x 16"L
Engine5.5 HP Honda GC OHV
Oil typeSAE 30W Detergent
Weight54 lbs.
MaterialAluminum & cast iron

Maintenance

⚠ WARNING To prevent accidental starting always remove spark plug, or disconnect and ground spark plug wire before attempting to service or remove any component.

MECHANICAL SEAL REPLACEMENT

Refer to Figures 1 and 2.

IMPORTANT: Replace seal seat, (Ref. No. 13) and seal head (Ref. No. 14) at the same time to ensure proper mating of mechanical seal components!

1. Unthread fasteners (Ref. No. 3) and remove casing (Ref. No. 6) and casing seal (Ref. No. 5) from adapter (Ref. No. 4).
2. Unthread impeller fastener (Ref. No. 16) and remove impeller (Ref. No. 11),

impeller seal (Ref. No. 17) and shims (Ref. No. 12).

NOTE: To keep shaft from turning, hold impeller while unthreading impeller fastener.

3. Pry seal seat (Ref. No. 13) from impeller recess with a screwdriver (See Figure 1).

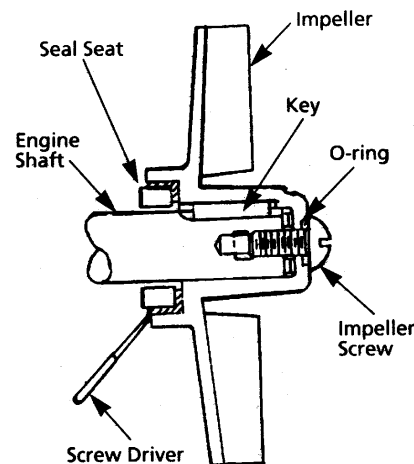

Figure 1 – Mechanical Seal Replacement

4. Remove adapter by unthreading adapter fasteners (Ref. No. 15). Press old seal head (Ref. No. 14) out of adapter by pushing from engine side.

5. Clean adapter and impeller seal recesses before installing new pieces.
6. Carefully wipe polished surface of new seal seat with a clean cloth.
7. Wet rubber portion of seal seat with a light coating of soapy water.
8. Press seal seat squarely into recess in impeller. If seal seat does not press squarely into recess, it can be adjusted by pushing on it with a piece of pipe. Always use a piece of cardboard between pipe and seal seat to avoid scratching lapped, highly polished surface of seal seat (handle it carefully).
9. After seal seat is in place, ensure that it is clean and has not been marred.
10. Using a clean cloth, wipe shaft and make certain that it is completely clean.

⚠ CAUTION Do not touch or wipe polished face of seal head.

11. Secure adapter on engine mounting face, using fasteners.

⚠ CAUTION Tighten adapter fasteners evenly to avoid cocking or damaging adapter.

13. Replace impeller and shims, ensuring that key (Ref. No. 18) is in place and lock impeller to shaft with fastener and impeller seal on fastener.
14. Remount casing seal and pump casing with fasteners and nuts.

IMPORTANT: Always inspect all seals

Performance Chart

Model	GPH of Water at Total Head in Feet							Max. Head*
	20'	30'	40'	50'	60'	70'	80'	
276E-96	8300	7500	6500	5500	4300	3200	1300	84 ft.
(*) Shut-off; to convert to psi, divide by 2.31								

2-Inch Dewatering Pump

Maintenance (Continued)

when unit is disassembled. Replace when rubber is hard, cracked, or worn.

When reassembling parts with o-ring seals or gaskets, it is sometimes helpful to apply a small amount of soapy water on o-ring so that parts slide over o-ring without pinching or shaving it.

SHIM ADJUSTMENT

When installing a replacement impeller, it may be necessary to vary the number of shims (Ref. No. 12) that will be required. This is easily done by adding one 0.010" shim more than was removed, and reassembling pump as described.

Ensure that casing is snugly in place and check shaft to make sure it is turning freely. If it turns freely, check to ensure that adapter (Ref. No. 4) and casing (Ref. No. 6) are fitted tight together. If they are not, tighten fasteners (Ref. No. 3) and recheck shaft for free turning. Tighten carefully, turning shaft while tightening. If shaft seizes before fasteners are completely tight, disassemble pump and remove one shim and repeat reassembly.

If any time during above operation shaft does not turn free, follow procedure indicated above and repeat procedure.

Above procedure ensures that pump will have proper running clearance (less than 0.010") between impeller and casing and perform like a new unit with new impeller or motor.

For Replacement Parts, contact dealer where pump was purchased.

Please provide following information:

- Model number
- Serial number (if any)
- Part description and number as shown in parts list

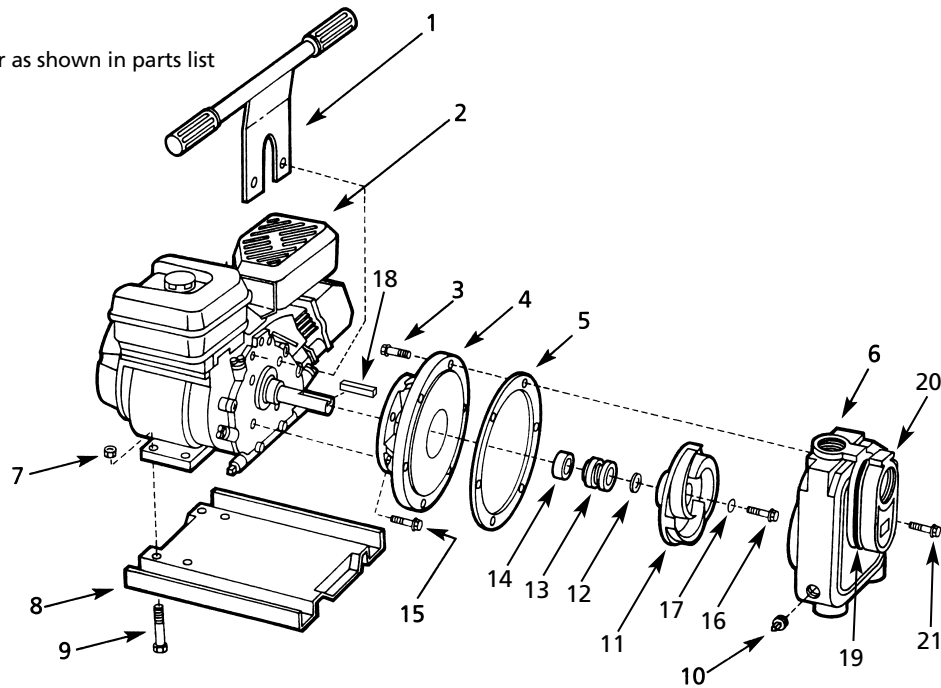

Figure 2 – Repair Parts Illustration

Repair Parts List

Ref. No.	Description	Part Number	Qty.
1	Carry handle	1549-007-90	1
2	Engine	Δ	1
3	1/4"-20 UNC x 3/4" SS hex screw	*	6
4	Adapter	Δ	1
5	Gasket	1478-000-00	1
6	Casing (cast iron only)	1497-001-02	1
7	5/16"-18 UNC Hex flange nut	*	4
8	Base	4220-100-0	1
9	5/16"-18 UNC x 1 1/2" Hex cap screw	*	4
10	1/2" NPT Pipe plug	*	3
11	Impeller	Δ	1
12	Impeller shim set	3827-172-90	1
13&14	Seal assembly -Buna N	1640-162-95	1
15	5/16"-24 UNF x 3/4" Hex flange screw	*	4
16	Impeller fastener	1753-001-00	1
17	Fastener seal -Buna N	2102-004-00	1
18	Key 3/16" x 3/16" x 1"	*	1
19	Flapper valve assembly	1683-000-90	1
20	Suction plate (cast iron only)	1501-000-01	1
21	1/4"-20 UNC x 3/4" Hex head cap screw	*	6

(*) Standard hardware item, available locally.

(Δ) Not available.

