

Please read and save this Repair Parts Manual. Read this manual and the General Operating Instructions carefully before attempting to assemble, install, operate or maintain the product described. Protect yourself and others by observing all safety information. The Safety Instructions are contained in the General Operating Instructions. Failure to comply with the safety instructions accompanying this product could result in personal injury and/or property damage! Retain instructions for future reference.

Self-Priming Centrifugal Pumps

High Volume Dewatering Cast Iron Models

Refer to form 1808-634-00 for General Operating and Safety Instructions.

Description

These centrifugal pumps are self-priming (to 20 ft. lift) units designed for high volume liquid transfer - irrigation, de-watering, lawn sprinkling, etc. They can also accommodate semi-solids (up to 3/8" dia.), sediment laden liquids, and liquids with entrained air or gases. Units are equipped with flapper valves to shorten re-prime time. Handles liquids from 40° to 180° F (4° to 82° C). For use with non-flammable, non-abrasive liquids compatible with pump component materials.

Maintenance

⚠ WARNING

*Make certain
that unit is*

disconnected from power source before attempting to service or remove any component!

NOTE: The pump casing should be removed and inspected periodically to insure that any foreign material is not clogging internal pump parts. This unit is equipped with a dual volute pump casing. One of the volutes runs 180°, all the way from the side opposite the discharge into the discharge through a completely enclosed passageway. If foreign material clogs this area, it can be dislodged by using a wire or long spring.

MECHANICAL SEAL REPLACEMENT

Refer to Figure 1

IMPORTANT: Always replace both seal seat (Ref. No. 8) and seal head (Ref. No. 9) to ensure proper mating of components!

Performance

Model	GPM of Water at Total Head in Feet									Max. Head*
	10'	20'	30'	40'	50'	60'	70'	80'	90'	
2827, 282J, 282D, 282F	58	51	44	37	28	18	7	—	—	74 ft.
2825, 2826, 282C, 282K	78	72	64	56	46	35	20	—	—	78
2821, 2822, 282A, 282B	99	92	84	75	65	54	43	31	15	93
2828, 282L, 282E, 282M	117	112	102	92	82	70	56	42	24	95
2762, 2764, 276B, 276D	111	96	85	75	60	48	30	15	—	86
2761, 2763, 276A, 276C	127	115	103	90	76	60	40	20	—	93
2767, 2766	148	136	123	110	95	82	68	49	30	101

(*) Shut-off; To convert to psi, multiply by SG (specific gravity of liquid), then divided by 2.31.

inserting a new seal seat.

1. Unthread fasteners (Ref. No. 6) and remove pump casing (Ref. No. 14) and casing seal (Ref. No. 7) from adapter (Ref. No. 5).
 2. Unscrew impeller fastener (Ref. No. 13), (where applicable), and impeller (Ref. No. 11) separately by turning each counterclockwise.
- NOTE:** Most motors use an open end 7/16" wrench across flats on rear of motor shaft (remove bearing cap for access) to prevent shaft from turning. Other motor shafts have a screwdriver slot instead of flats.
3. Unscrew fasteners (Ref. Nos. 4 & 18) and remove adapter, foot (Ref. No. 19), and handle (Ref. No. 3) from motor (Ref. No.1) mounting face. Seal head will come loose at this time.
 4. Push seal seat from adapter recess with a screwdriver.
 5. Clean adapter recess before

6. Carefully wipe polished surface of new seal seat with a clean cloth.
 7. Wet rubber portion of seal seat with a light coating of soapy water.
 8. Press new seal seat squarely into cavity in adapter. If seal seat does not press squarely into cavity, it can be adjusted in place by pushing on it with a piece of pipe. Always use a piece of cardboard between pipe and seal seat to avoid scratching seal seat. (This is a lapped surface and must be handled very carefully.)
 9. After seal seat is in place, insure that it is clean and has not been marred.
 10. Using a clean cloth, wipe shaft and make certain that it is perfectly clean.
- NOTE:** If removed, slide slinger washer (Ref. No. 2) onto shaft until it is located approximately 1/8" from face of motor bearing hub.
11. Secure adapter, foot, and handle on motor mounting face. Carefully guide motor shaft through seal seat.
 12. Apply a light coating of soapy water to inside rubber portion of seal head and slide onto shaft (with

Self-Priming Centrifugal Pumps

High Volume Dewatering Cast Iron Models

Specifications

Model	DRIVER		Power Supply @60 Hz	PUMP Suction x Discharge*	Weight (lbs.)
	HP	Enclosure			
2827-95	1/2	ODP	115/230VAC, 1 Phase	1 1/2" x 1 1/2"	47
282J-95	1/2	ODP	230/460VAC, 3 Phase	1 1/2 x 1 1/2	50
282D-95	3/4	TEFC	115/230VAC, 1 Phase	1 1/2 x 1 1/2	52
282F-95	3/4	TEFC	230/460VAC, 3 Phase	1 1/2 x 1 1/2	49
2825-95	3/4	ODP	115/230VAC, 1 Phase	1 1/2 x 1 1/2	50
2826-95	3/4	ODP	230/460VAC, 3 Phase	1 1/2 x 1 1/2	49
282C-95	1	TEFC	115/230VAC, 1 Phase	1 1/2 x 1 1/2	54
282K-95	1	TEFC	230/460VAC, 3 Phase	1 1/2 x 1 1/2	50
2821-95	1 1/2	ODP	115/230VAC, 1 Phase	1 1/2 x 1 1/2	62
2822-95	1 1/2	ODP	230/460VAC, 3 Phase	1 1/2 x 1 1/2	58
282A-95	2	TEFC	115/230VAC, 1 Phase	1 1/2 x 1 1/2	74
282B-95	2	TEFC	230/460VAC, 3 Phase	1 1/2 x 1 1/2	68
2828-95	2	ODP	115/230VAC, 1 Phase	1 1/2 x 1 1/2	69
282L-95	2	ODP	230/460VAC, 3 Phase	1 1/2 x 1 1/2	68
282E-95	3	TEFC	230VAC, 1 Phase	1 1/2 x 1 1/2	79
282M-95	3	TEFC	230/460VAC, 3 Phase	1 1/2 x 1 1/2	79
2762-95	1 1/2	ODP	115/230VAC, 1 Phase	2 x 2	68
2764-95	1 1/2	ODP	230/460VAC, 3 Phase	2 x 2	69
276B-95	2	TEFC	115/230VAC, 1 Phase	2 x 2	79
276D-95	2	TEFC	230/460VAC, 3 Phase	2 x 2	68
2761-95	2	ODP	115/230VAC, 1 Phase	2 x 2	74
2763-95	2	ODP	230/460VAC, 3 Phase	2 x 2	67
276A-95	3	TEFC	230VAC, 1 Phase	2 x 2	78
276C-95	3	TEFC	230/460VAC, 3 Phase	2 x 2	76
2767-95	3	ODP	230VAC, 1 Phase	2 x 2	75
2766-95	3	ODP	230/460VAC, 3 Phase	2 x 2	74

(ODP) Open Drip Proof; (TEFC) Totally Enclosed Fan Cooled

(*) Standard NPT (female) pipe thread.

NOTE: Driver data is subject to change without notice, see label on driver for actual specifications.

Maintenance (Continued)

sealing face first) so that rubber portion is just up over shaft shoulder.

▲ CAUTION *Do not touch or wipe polished face of seal head.*

13. Replace any impeller shims (Ref. No. 10) which may have been removed in disassembly. (See "Shim Adjustment" below.)
14. Screw impeller back into place, tightening until it is against shaft shoulder.
15. Replace impeller nut (where applicable), and tighten until snug.
16. Remount casing seal and pump casing on adapter.

IMPORTANT: Always use a new casing gasket whenever unit is disassembled.

SHIM ADJUSTMENT

When installing a replacement impeller (Ref. No. 11) or motor (Ref. No. 1), it may be necessary to adjust number of shims (Ref. No. 10) to insure proper running clearance between impeller and casing. Proceed as follows:

NOTE: A proper running clearance is less than 0.010".

1. For impeller replacement, add one 0.010" shim in addition to those removed originally.
2. For motor replacement, add two 0.010" shims in addition to those removed during disassembly.
3. Reassemble the pump as described in steps 15, 16 & 17.

IMPORTANT: Ensure that the casing is snugly in place and check shaft to make

sure it is turning freely (use screwdriver slot in motor to turn shaft). If it turns freely, check to insure that adapter and casing are fitted tight together. If they are not, tighten fasteners (Ref. Nos. 4, 6 and 18) and recheck shaft for free turning. Tighten carefully, turning shaft while tightening so that motor bearings are not damaged in the event that too many shims were installed. If shaft seizes before fasteners are completely tight, disassemble pump and remove one shim and repeat reassembly.

For Repair Parts, contact dealer where pump was purchased.

Please provide following information:

- Model number
- Serial number (if any)
- Part description and number as shown in parts list

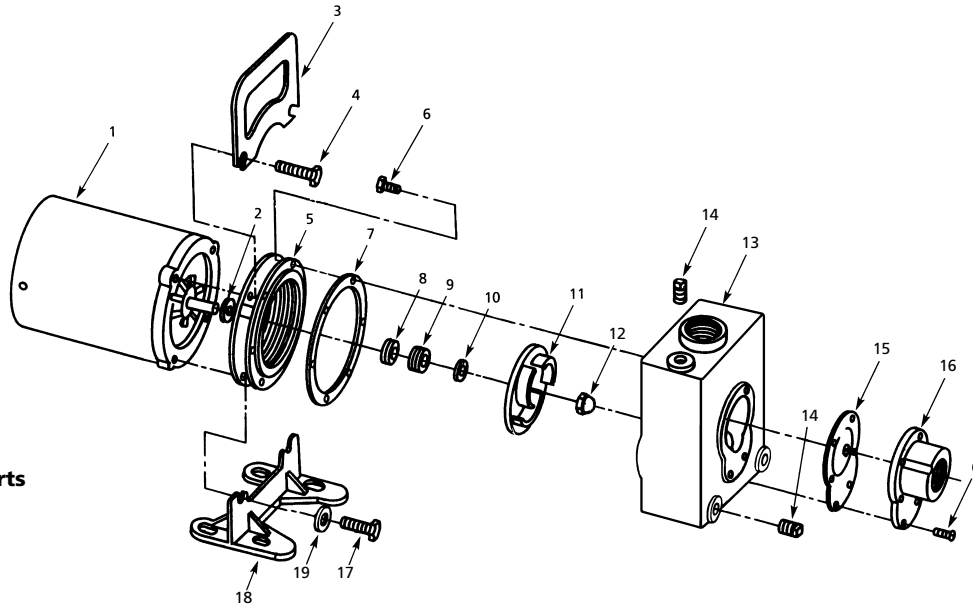

Figure 1 – Repair Parts Illustration

Repair Parts List

Ref. No.	Description	Part Number for Models:				Qty.	
		2827-95 (1/2HP) 282J-95 (1/2HP) 282D-95 (3/4HP) 282F-95 (3/4HP)	2825-95 (3/4HP) 2826-95 (3/4HP) 282C-95 (1HP) 282K-95 (1HP)	2821-95 (1 1/2HP) 2822-95 (1 1/2HP) 282A-95 (2HP) 282B-95 (2HP)	2828-95 (2HP) 282L-95 (2HP) 282E-95 (3HP) 282M-95 (3HP)		
1	Motor	-1 Phase ODP -3 Phase ODP -1 Phase TEFC -3 Phase TEFC	1626-009-00 1626-013-00 1626-051-00 1626-052-00	1626-010-00 1626-014-00 1626-069-00 1626-077-00	1626-012-00 1626-016-00 1626-070-00 1626-054-00	1626-024-00 1626-025-00 1626-071-00 1626-072-00	1
2	Slinger washer		1534-000-00	1534-000-00	1534-000-00	1534-000-00	1
3	Handle		1515-000-00	1515-000-00	1515-000-00	1515-000-00	1
4	Fastener		*	*	*	*	2
5	Adapter		1499-000-01	1499-000-01	1499-000-01	1499-000-01	1
6	Fastener		*	*	*	*	12
7	Casing seal		1478-000-00	1478-000-00	1478-000-00	1478-000-00	1
8&9	† Shaft seal assembly	-Buna N -Viton	1640-161-90 1640-161-91	1640-161-90 1640-161-91	1640-161-90 1640-161-91	1640-161-90 1640-161-91	1
10	Impeller shim set		1657-000-90	1657-000-90	1657-000-90	1657-000-90	1
11	Impeller	-1 Phase -3 Phase	1510-001-01 1510-001-02	1514-001-02 1514-001-03	1512-000-01 1510-000-01	1513-001-01 1513-001-02	1
12	Impeller fastener		1784-001-00	1784-001-00	1784-001-00	1784-001-00	1
13	Casing		1497-001-01	1497-001-01	1497-001-02	1497-001-02	1
14	Pipe plug		*	*	*	*	3
15	Flapper valve assembly	-Buna N -Viton	1674-000-90 1674-000-91	1674-000-90 1674-000-91	1674-000-90 1674-000-91	1674-000-90 1674-000-91	1
16	Suction plate		1501-000-01	1501-000-01	1501-000-01	1501-000-01	1
17	Fastener		*	*	*	*	2
18	Foot		1506-000-00	1506-000-00	1506-000-00	1506-000-00	1
19	Washer		*	*	*	*	2

(* Standard hardware item, available locally; (†) Seal head and seat available as set only.

For Repair Parts, contact dealer where pump was purchased.

Please provide following information:

- Model number
- Serial number (if any)
- Part description and number as shown in parts list

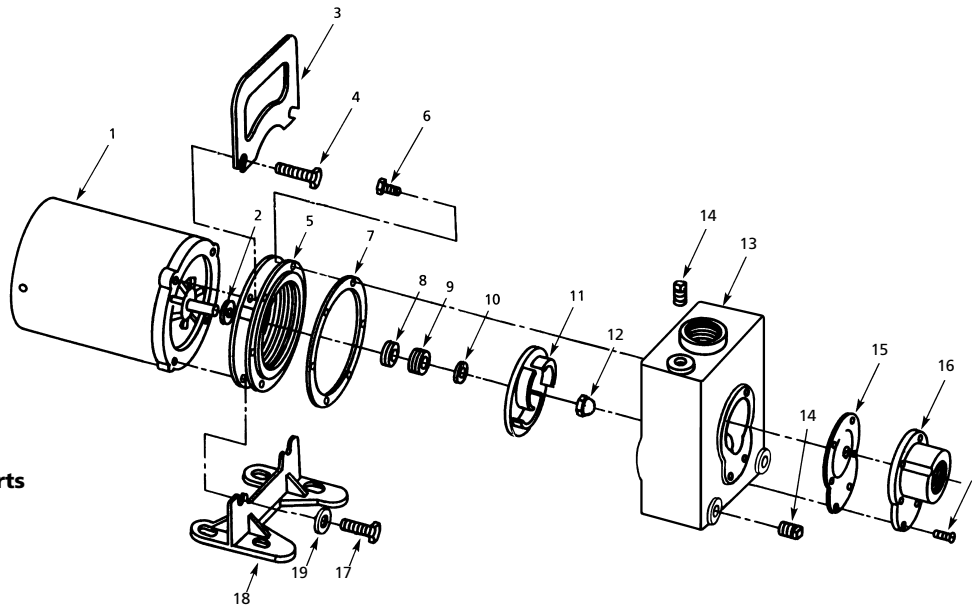

Figure 2 – Repair Parts Illustration

Repair Parts List

Ref. No.	Description	Part Number for Models:			Qty.	
		2762-95 (1 1/2HP) 2764-95 (1 1/2HP) 276B-95 (2HP) 276D-95 (2HP)	2761-95 (2HP) 2763-95 (2HP) 276A-95 (3HP) 276C-95 (3HP)	2767-95 (3HP) 2766-95 (3HP)		
1	Motor	-1 Phase ODP -3 Phase ODP -1 Phase TEFC -3 Phase TEFC	1626-012-00 1626-016-00 1626-070-00 1626-054-00	1626-024-00 1626-025-00 1626-071-00 1626-072-00	1626-026-00 1626-027-00 — —	1
2	Slinger washer		1534-000-00	1534-000-00	1534-000-00	1
3	Handle		1515-000-00	1515-000-00	1515-000-00	1
4	Fastener		*	*	*	2
5	Adapter		1499-000-01	1499-000-01	1499-000-01	1
6	Fastener		*	*	*	12
7	Casing seal		1478-000-00	1478-000-00	1478-000-00	1
8&9	† Shaft seal assembly	-Buna N -Viton	1640-161-90 1640-161-91	1640-161-90 1640-161-91	1640-161-90 1640-161-91	1
10	Impeller shim set		1657-000-90	1657-000-90	1657-000-90	1
11	Impeller	-1 Phase -3 Phase	1512-000-03 1510-000-03	1493-010-09 1491-000-01	1496-002-02 1496-002-02	1
12	Impeller fastener		1784-001-00	1784-001-00	1784-001-00	1
13	Casing		1484-001-01	1484-001-01	1484-001-01	1
14	Pipe plug		*	*	*	3
15	Flapper valve assembly	-Buna N -Viton	1683-000-90 1683-000-91	1683-000-90 1683-000-91	1683-000-90 1683-000-91	1
16	Suction plate		1487-000-01	1487-000-01	1487-000-01	1
17	Fastener		*	*	*	2
18	Foot		1506-000-00	1506-000-00	1506-000-00	1
19	Washer		*	*	*	2

(* Standard hardware item, available locally; (†) Seal head and seat available as set only.